

Introduction to Vector Diagrams



POWERMETRIX

Steve Hudson, P.E.

VP of Hardware Engineering

10737 Lexington Drive

Knoxville, TN 37932

Phone: (865) 966-5856

www.powermetrix.com



AC Theory Review – Sine Wave

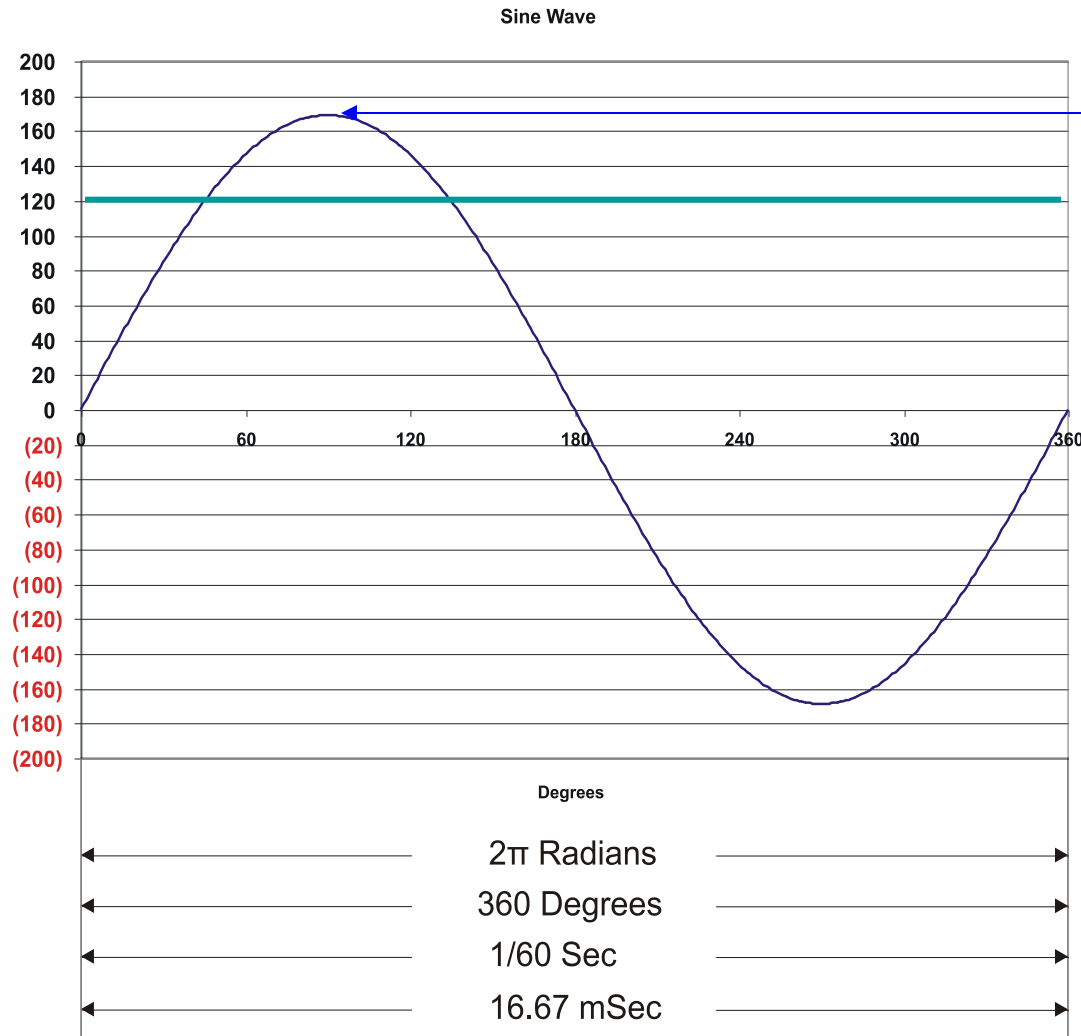

$$V = V_{pk} \sin(2\pi ft - \theta)$$

Where V_{pk} is peak voltage

f is frequency

t is time

θ (theta) is phase

$$V_{pk} = \sqrt{2} V_{rms}$$

$$V = \sqrt{2} V_{rms} \sin(2\pi ft - \theta)$$

$$V_{rms} = 120V$$

$$V_{pk} = 169V$$

$$f = 60Hz$$

$$\theta = 0^\circ$$

Phase Relationship

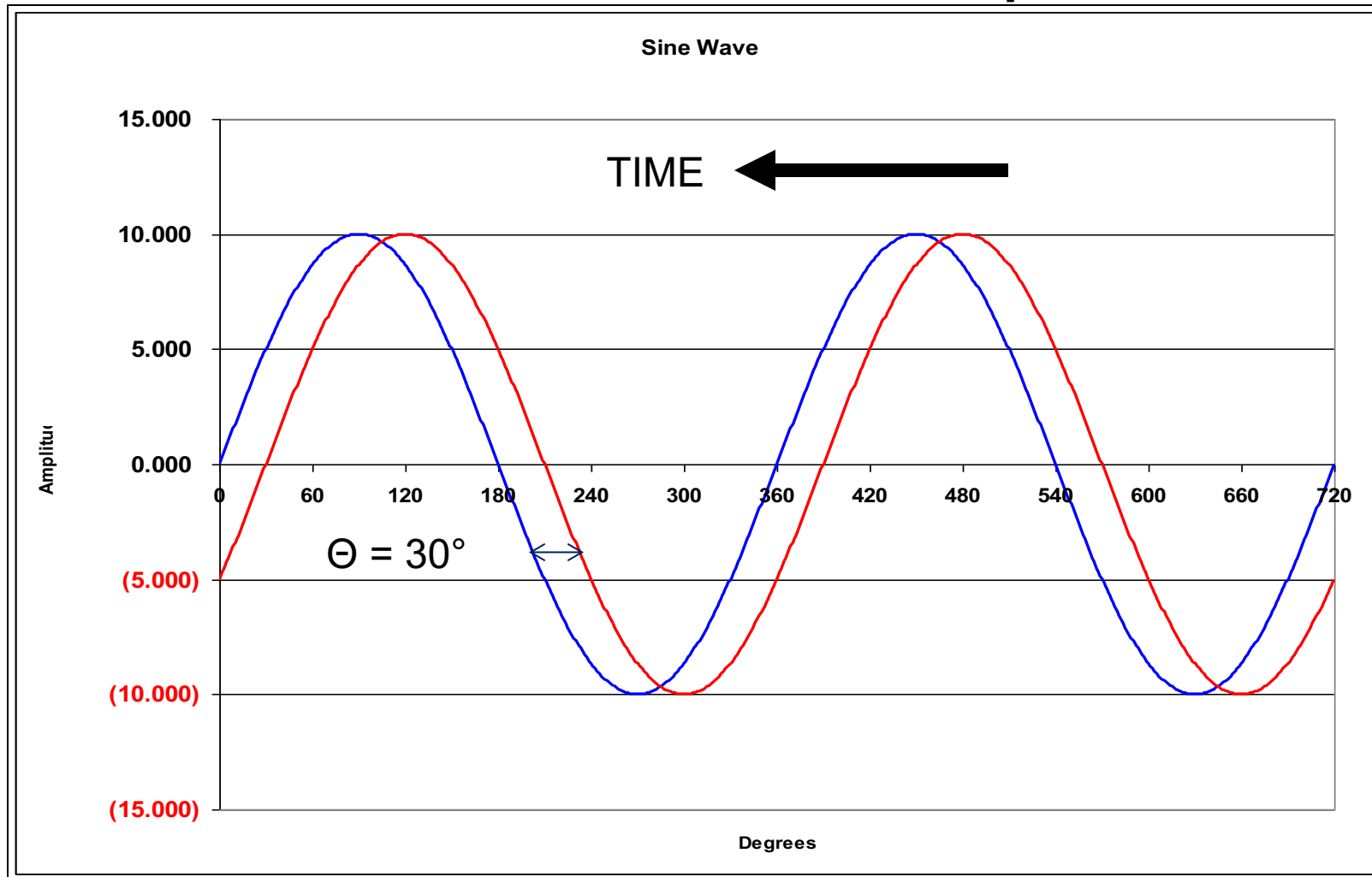

Current is lagging Voltage by 30°

Three Phase Theory

Single Phase - Voltage Plot

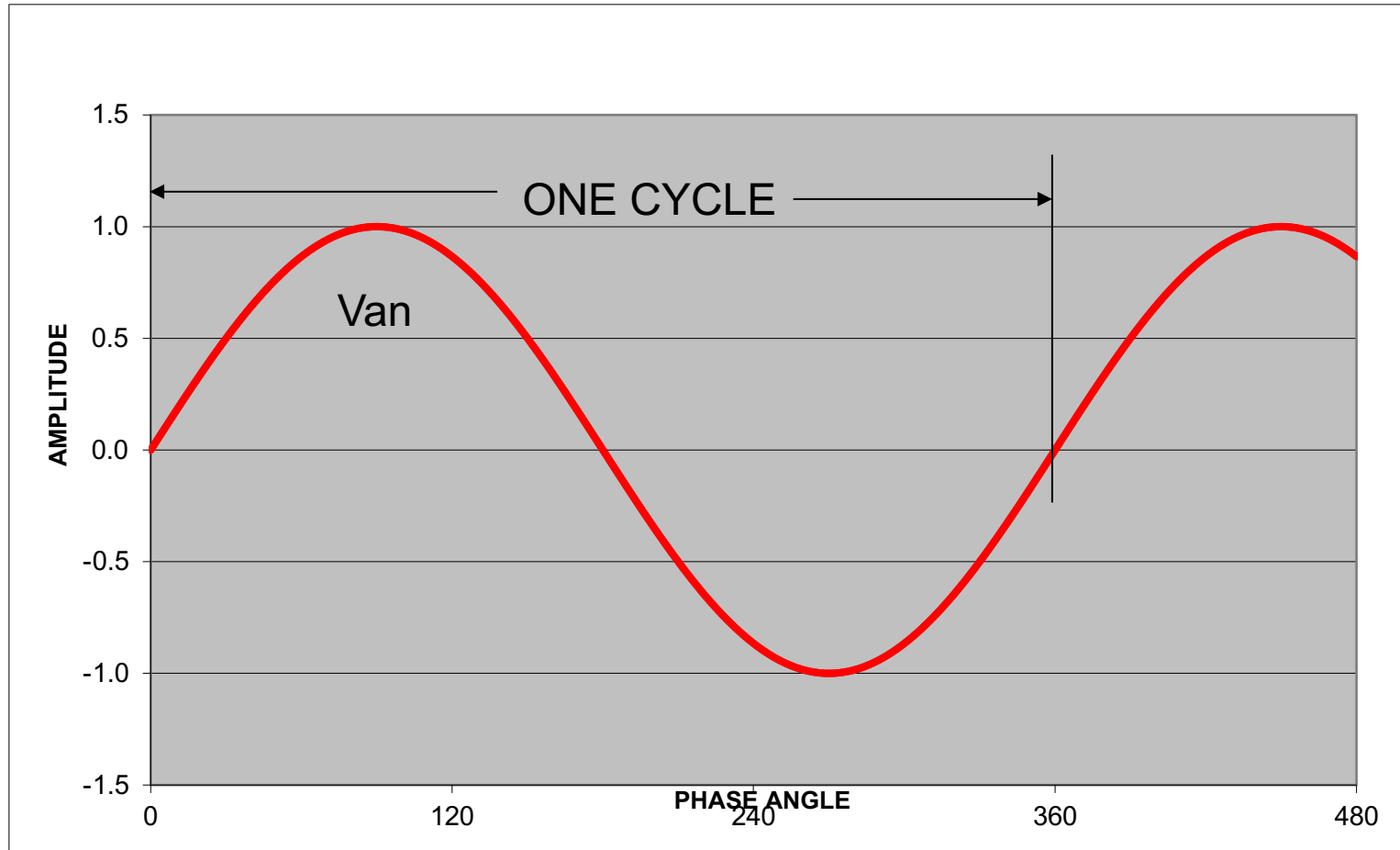

Three Phase Theory

Two Phases - Voltage Plot

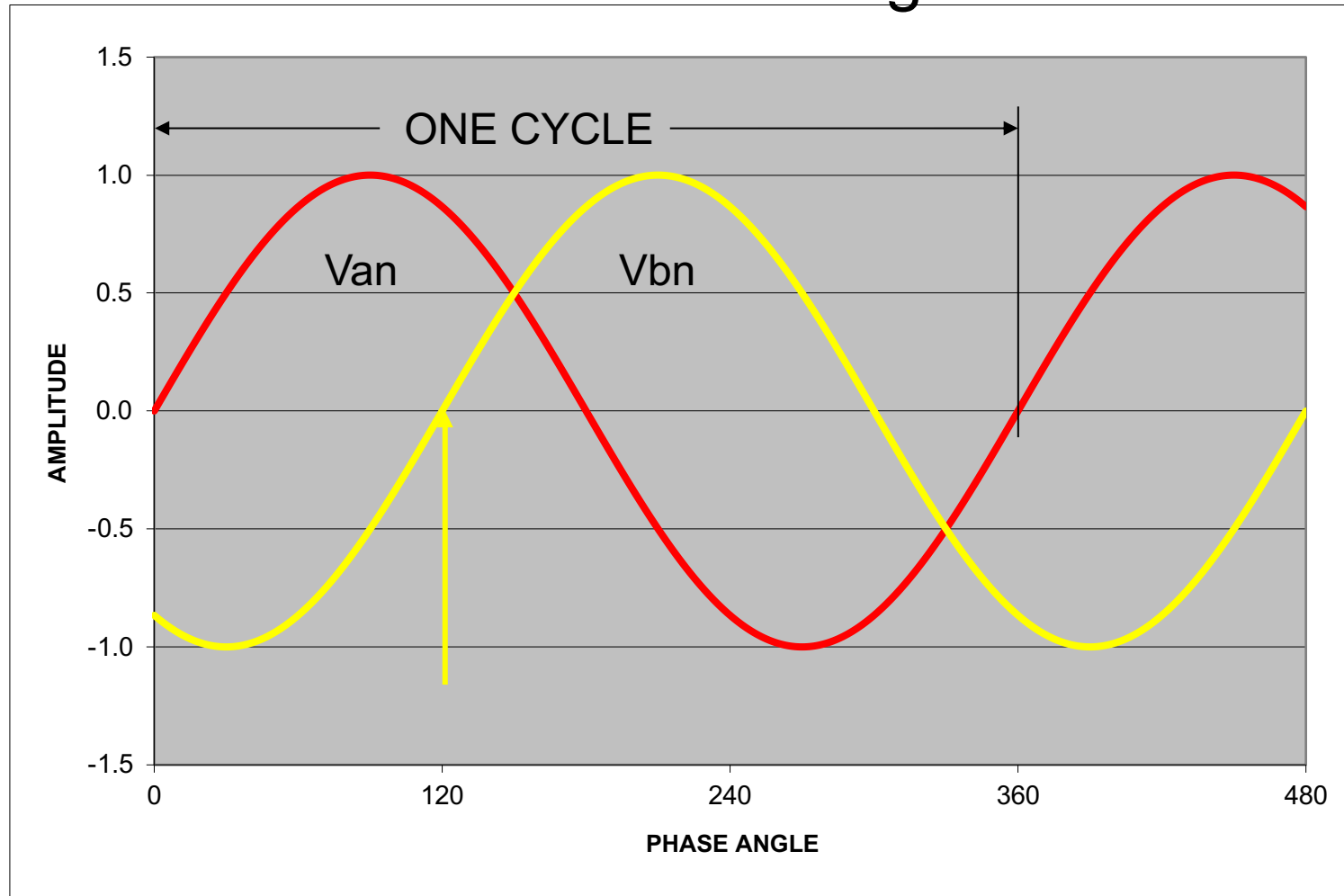

Three Phase Theory

Three Phase - Voltage Plot

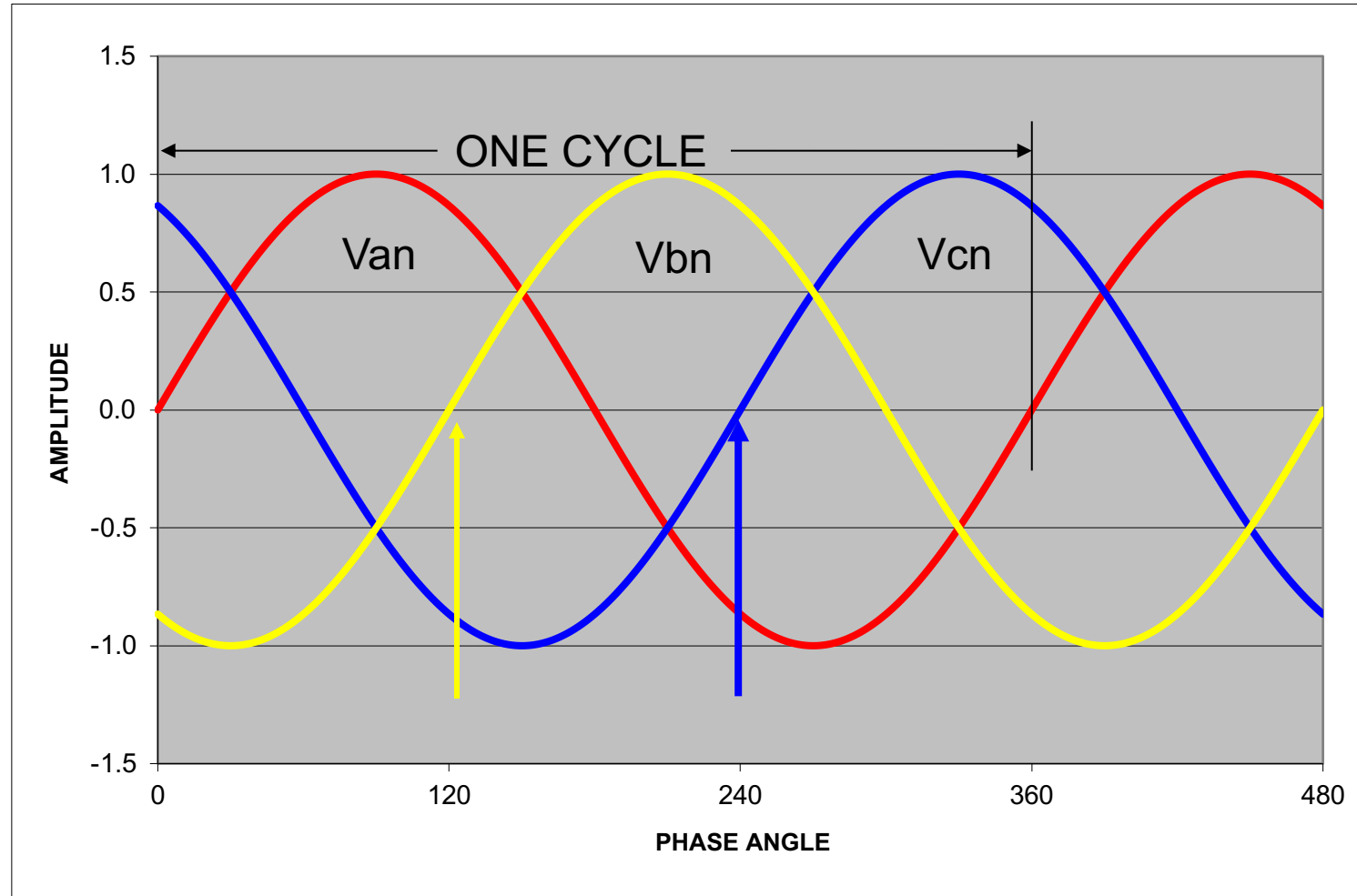

Three Phase Power At the Generator

Three voltage vectors
each separated by
 120° .

Peak voltages
essentially equal.

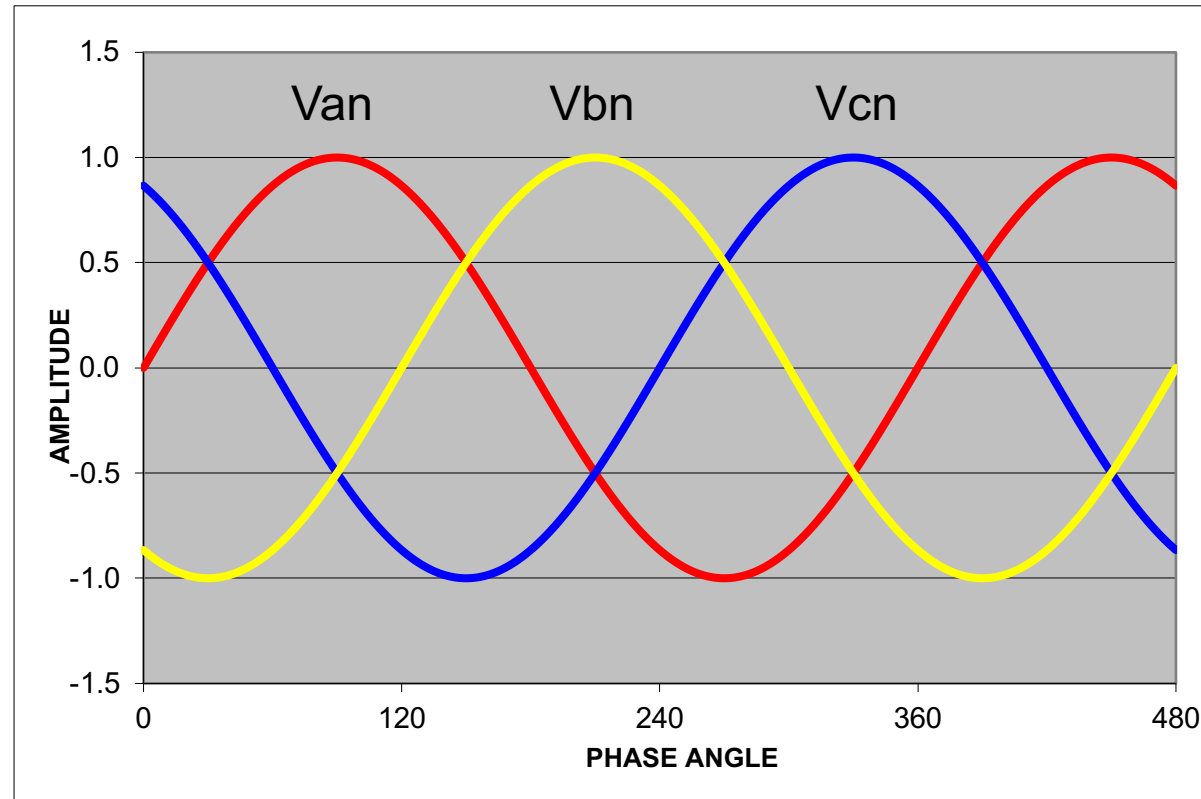

Most of what makes three phase systems seem complex is what we do to this simple picture in the delivery system and loads.

Three Phase Power

Basic Concept – Phase Rotation

Phase Rotation:

The order in which the phases reach peak voltage.

There are only two possible sequences:

A-B-C (previous slide)

C-B-A (this slide)

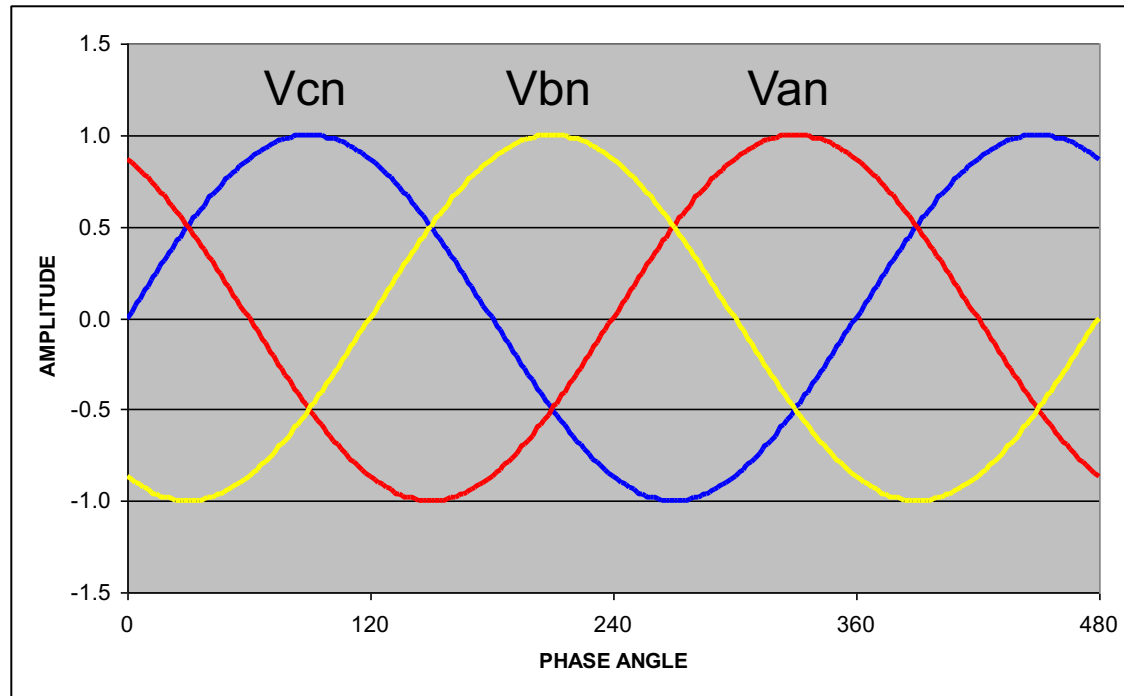

Phase rotation is important because the direction of rotation of a three phase motor is determined by the phase order.

Three Phase Theory

Phasors and Vector Notation

- Phasors are a graphical means of representing the amplitude and phase relationships of voltages and currents.

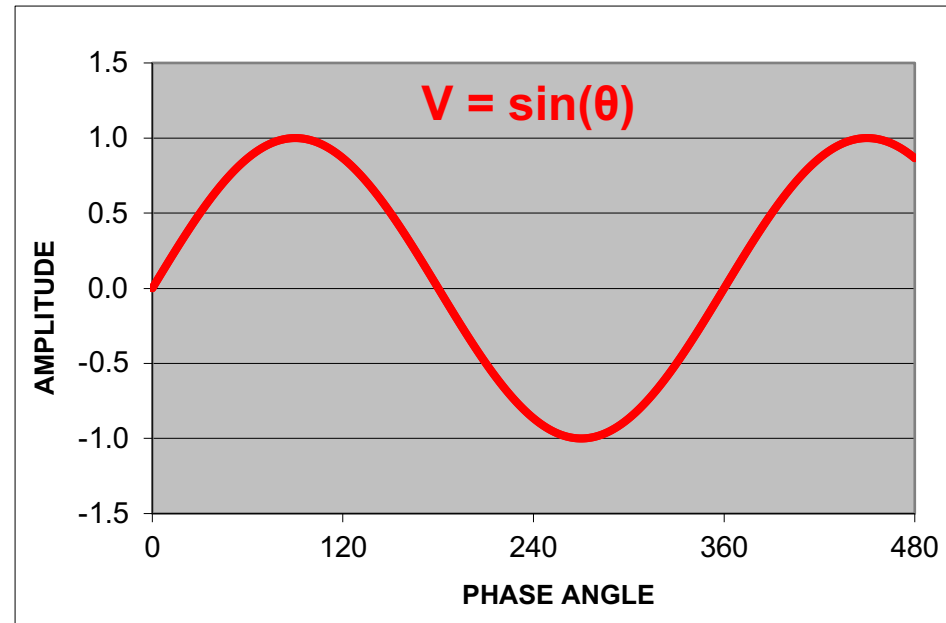
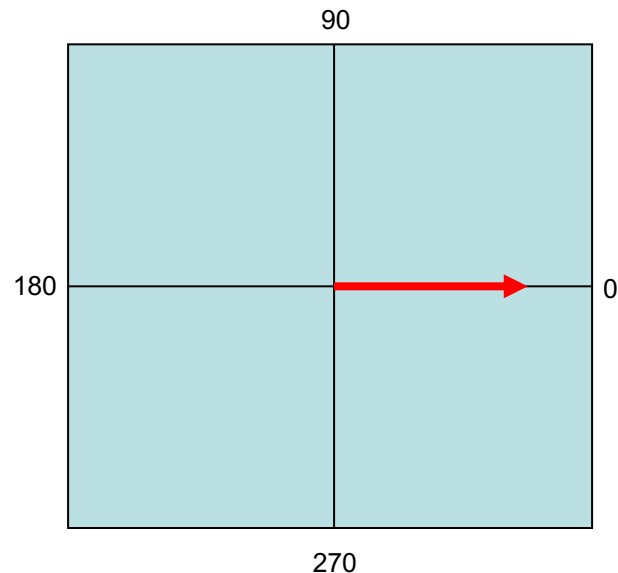

Three Phase Power

Phasors and Vector Notation

- As stated in the Handbook of Electricity Metering, by common consent, counterclockwise phase rotation has been chosen for general use in phasor diagrams.

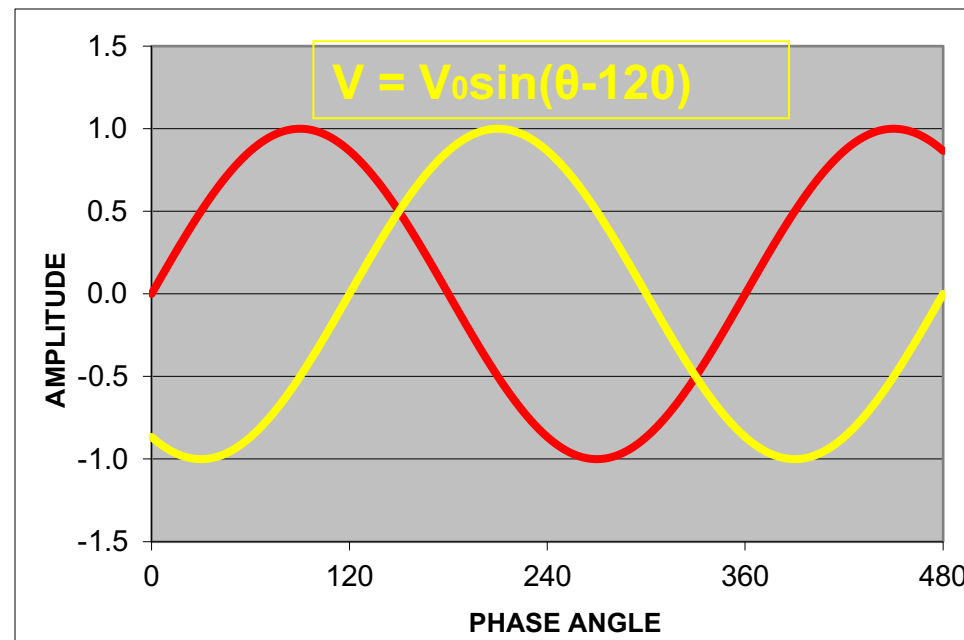
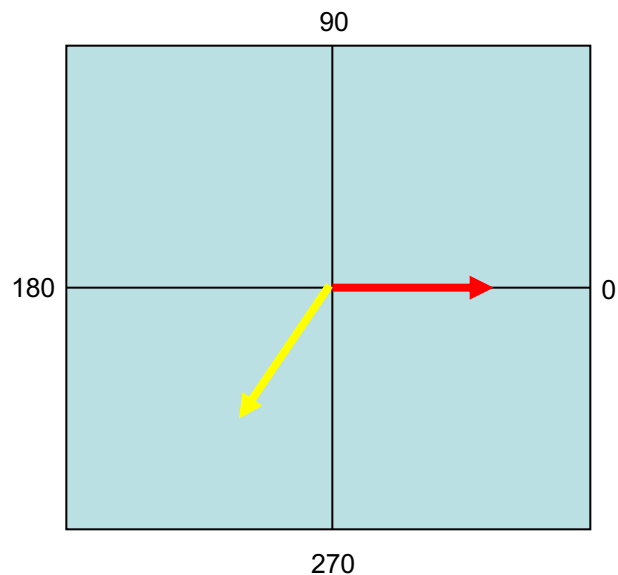

Three Phase Power

Phasors and Vector Notation

- The phasor diagram for a simple 3-phase system has three voltage phasors equally spaced at 120° intervals.
- Going clockwise the order is A – B – C.

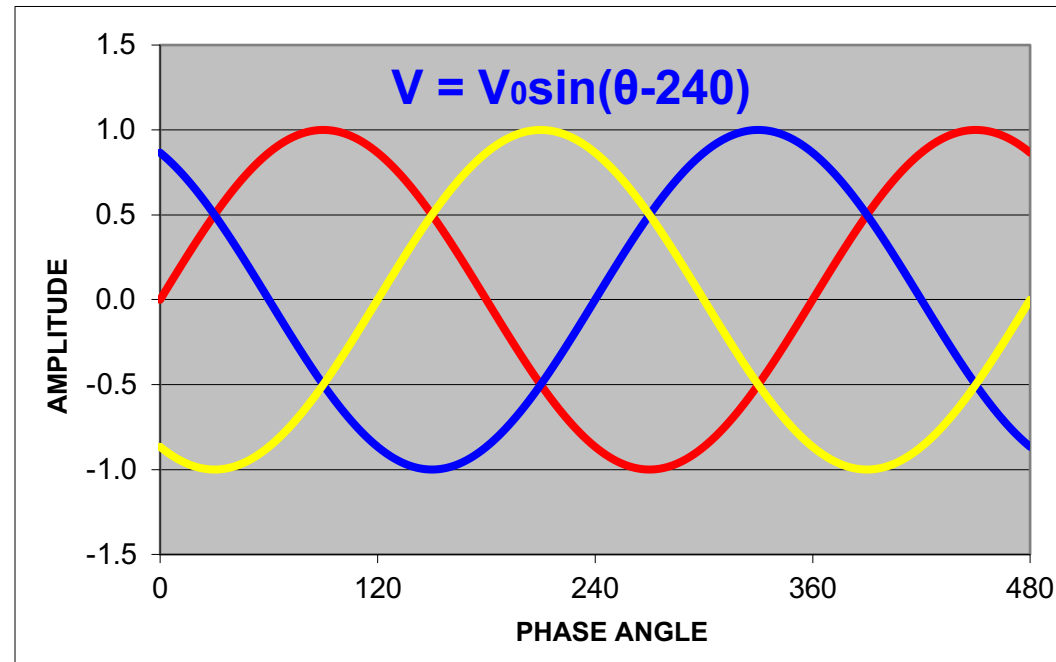
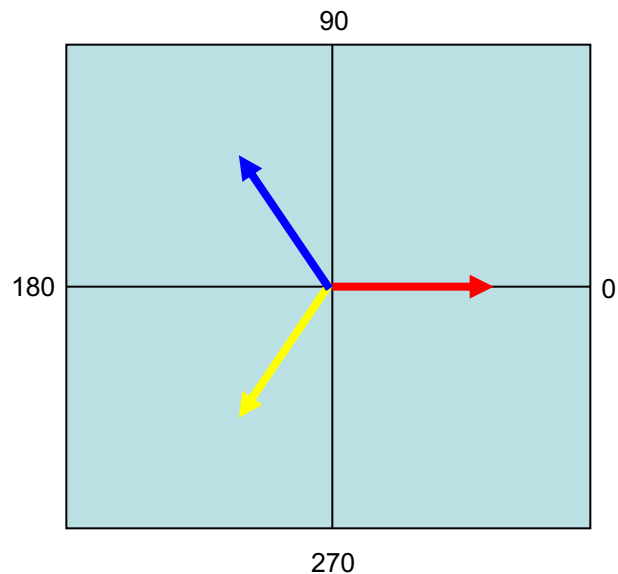

Resistive Load

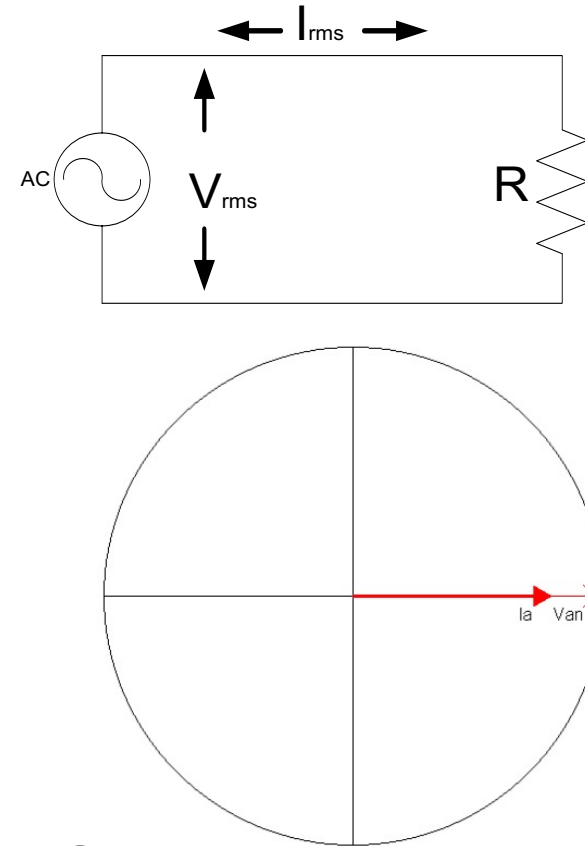
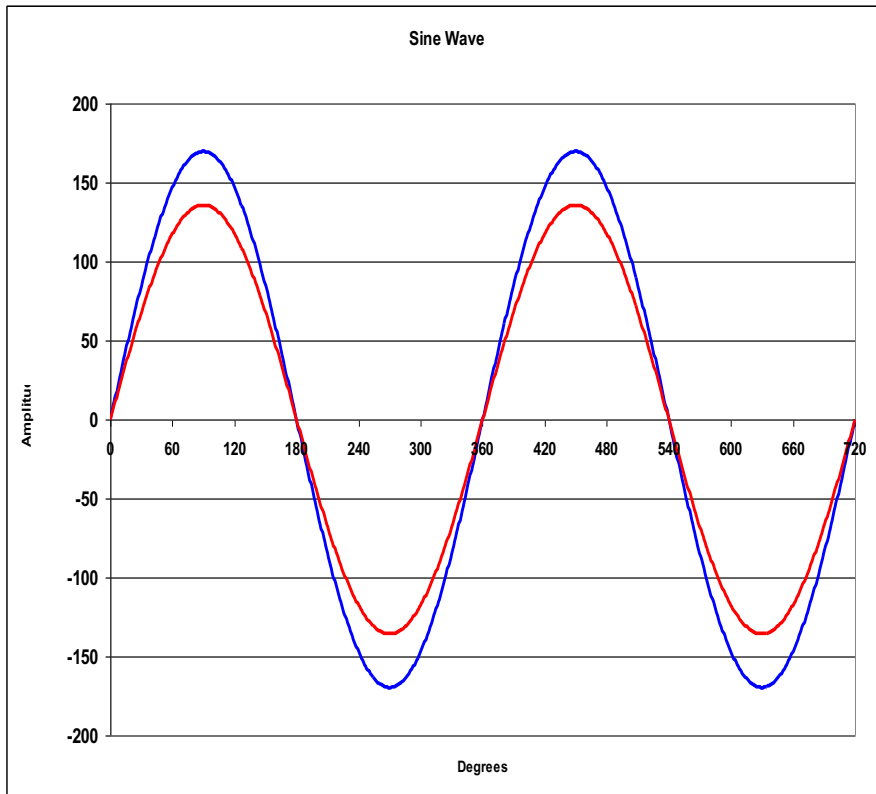

A purely resistive load has ZERO phase angle. The voltage and current vectors overlap.

Resistive Load

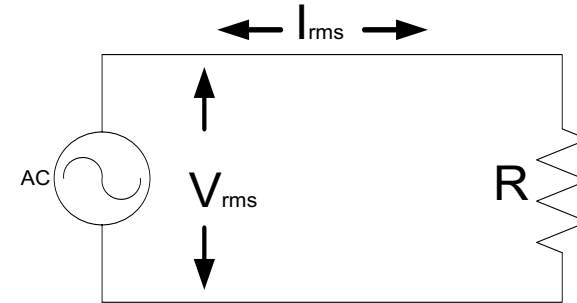
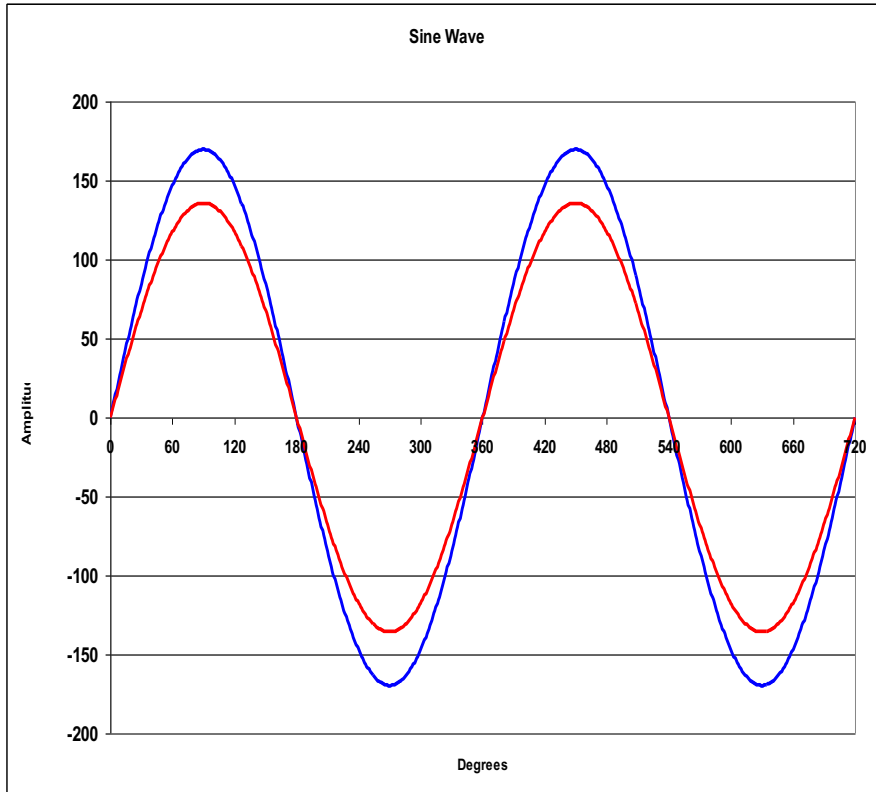

Resistive Example:

$$V = 120V$$

$$I = 10A$$

$$\Theta = 0^\circ$$

$$\cos 0^\circ = 1$$

$$\sin 0^\circ = 0$$

$$\text{Active Power (W)} = V I \cos (\theta) = 120 * 10 * 1 = 1200 \text{ W}$$

$$\text{Reactive Power (VAR)} = V I \sin (\theta) = 120 * 10 * 0 = 0 \text{ VAR}$$

$$\text{Apparent Power (VA)} = V I = 120 * 10 = 1200 \text{ VA}$$

$$\text{PF} = W / \text{VA} = \cos (\theta) = 1$$

Resistive Load

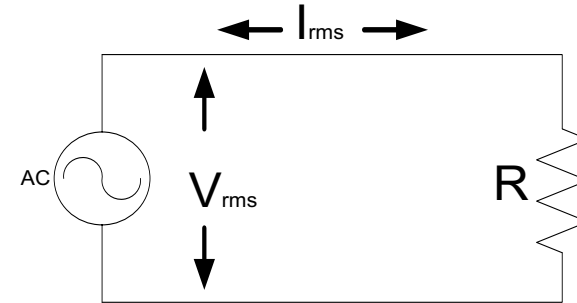
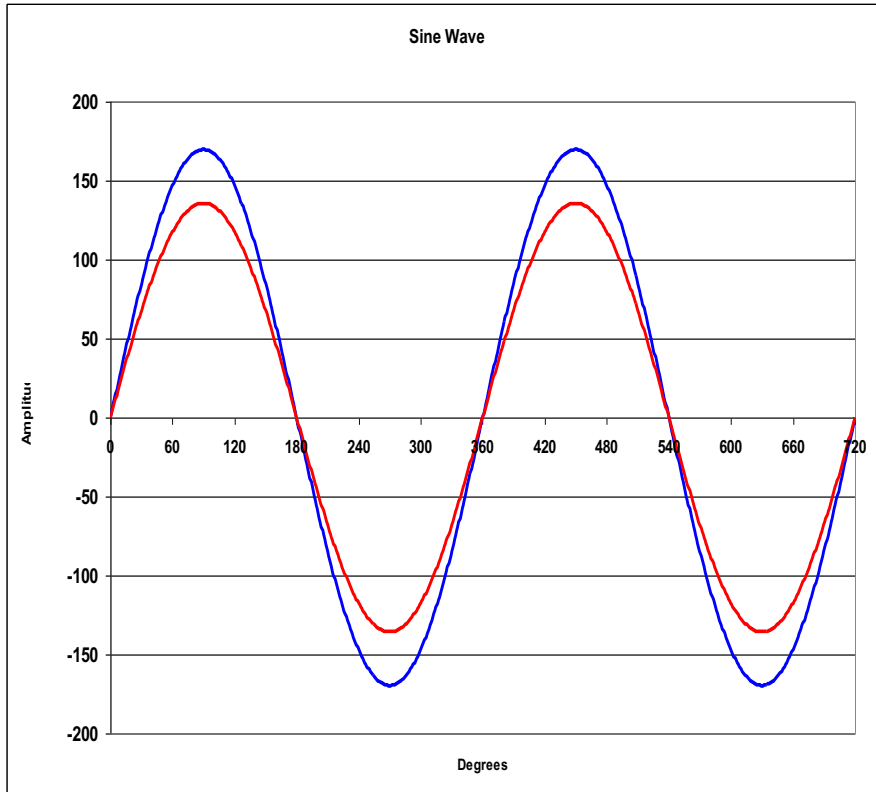

A purely resistive load will:

- Only create Watts
- Create NO VARs
- Have a PF = 1 and phase angle of 0°

Resistive Load

For a resistive load: $p = vi = 2VI\text{Sin}^2(\omega t) = VI(1 - \text{Cos}(2\omega t))$

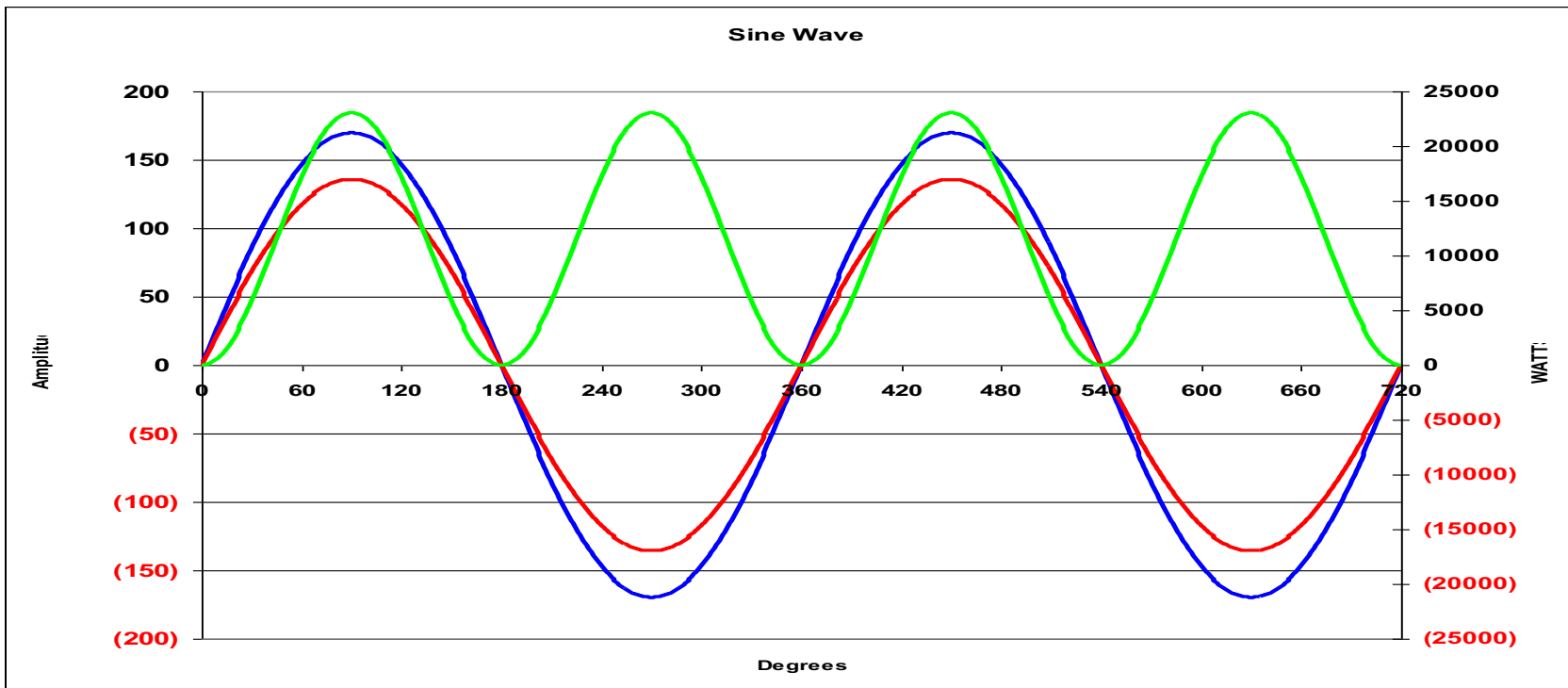

A resistive load consumes only Watts, so the power will always be delivered (positive).

Inductive Load

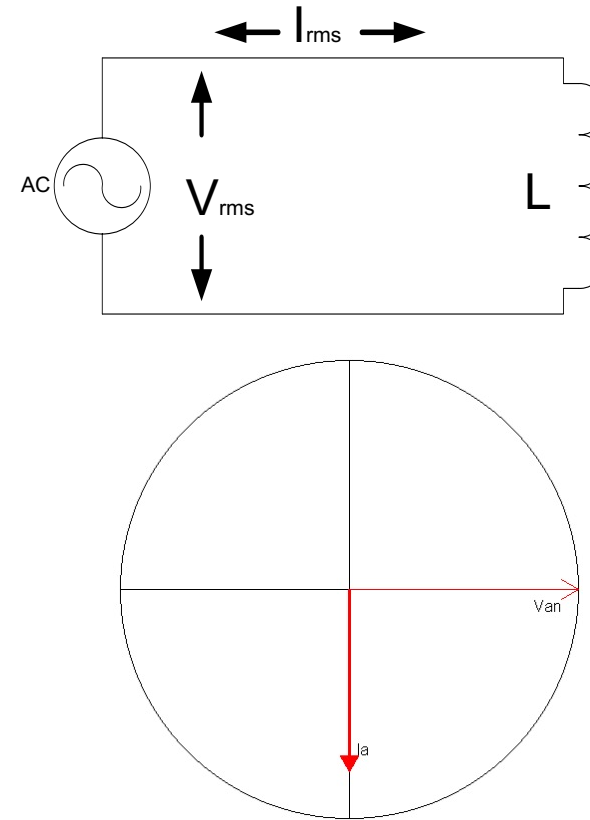
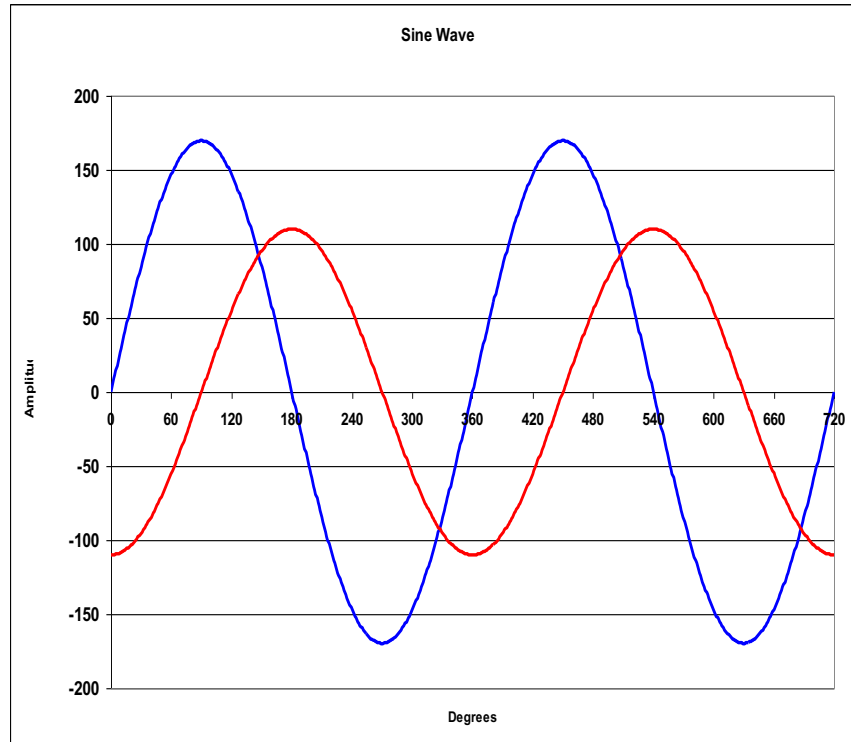

A purely inductive load has $+90^\circ$ phase angle. Clockwise vectors are **LAGGING** as current lags voltage.

Inductive Load

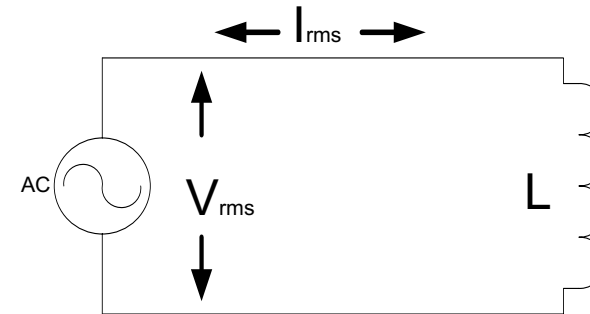
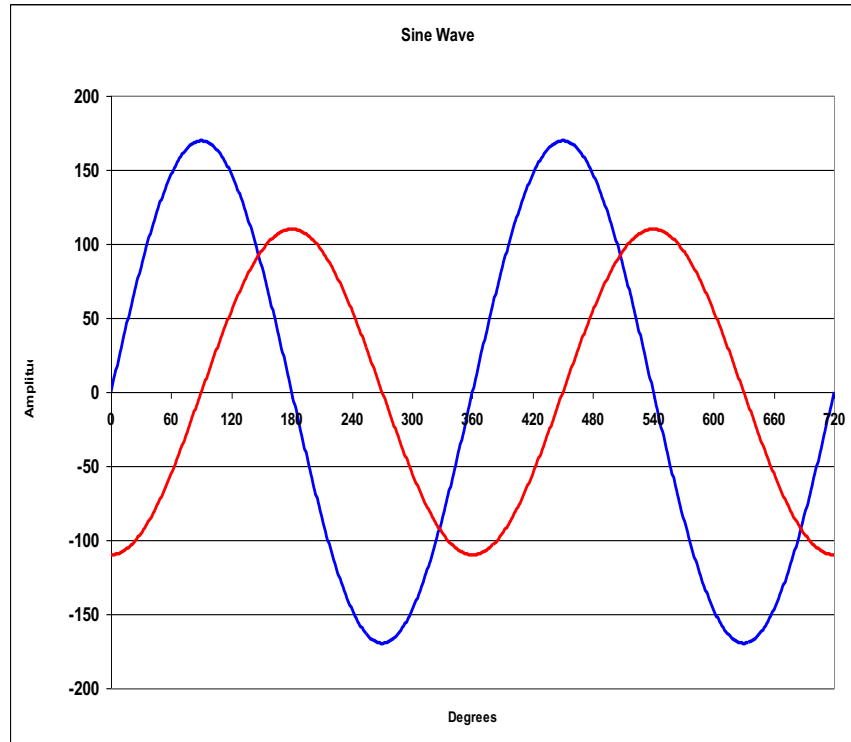

Inductive Example:

$$V = 120V$$

$$I = 10A$$

$$\Theta = 90^\circ$$

$$\text{Cos } 90^\circ = 0$$

$$\text{Sin } 90^\circ = +1$$

$$\text{Active Power (W)} = V I \cos (\theta) = 120 * 10 * 0 = 0 W$$

$$\text{Reactive Power (VAR)} = V I \sin (\theta) = 120 * 10 * +1 = +1200 \text{ VAR}$$

$$\text{Apparent Power (VA)} = V I = 120 * 10 = 1200 \text{ VA}$$

$$\text{PF} = W / \text{VA} = \cos (\theta) = 0$$

Inductive Load

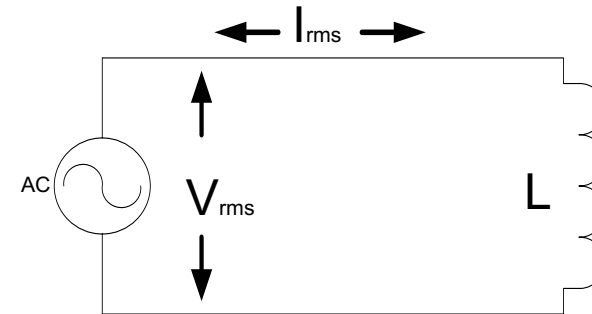
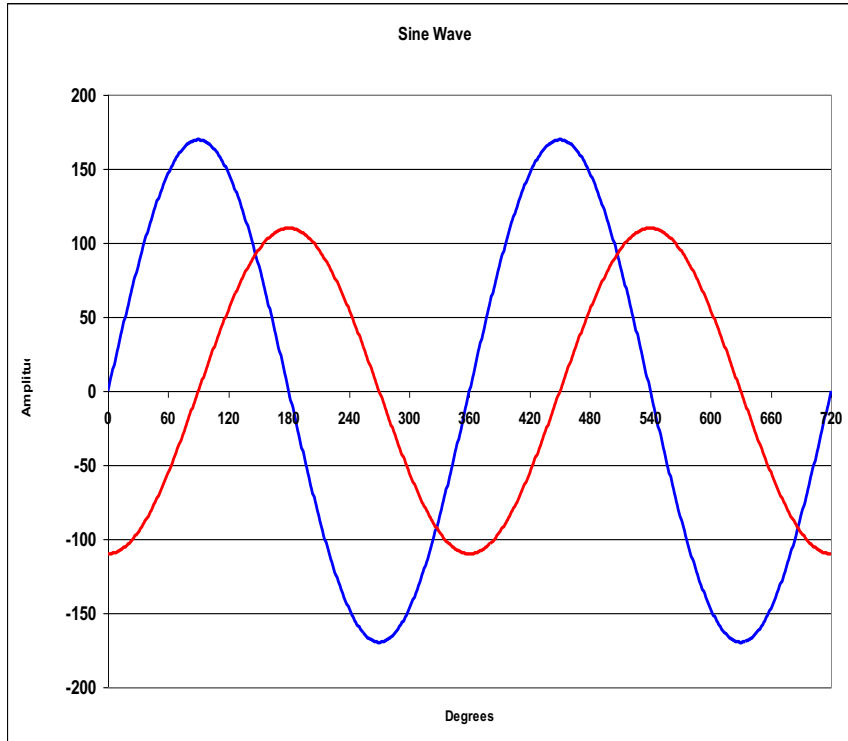

A purely inductive load will:

- Only create positive VARs
- Create NO Watts
- Have a PF = 0 and phase angle of 90° lagging

Inductive Load

For an inductive load: $p = vi = 2VISin(\omega t)Sin(\omega t - 90) = -VISin(2\omega t)$

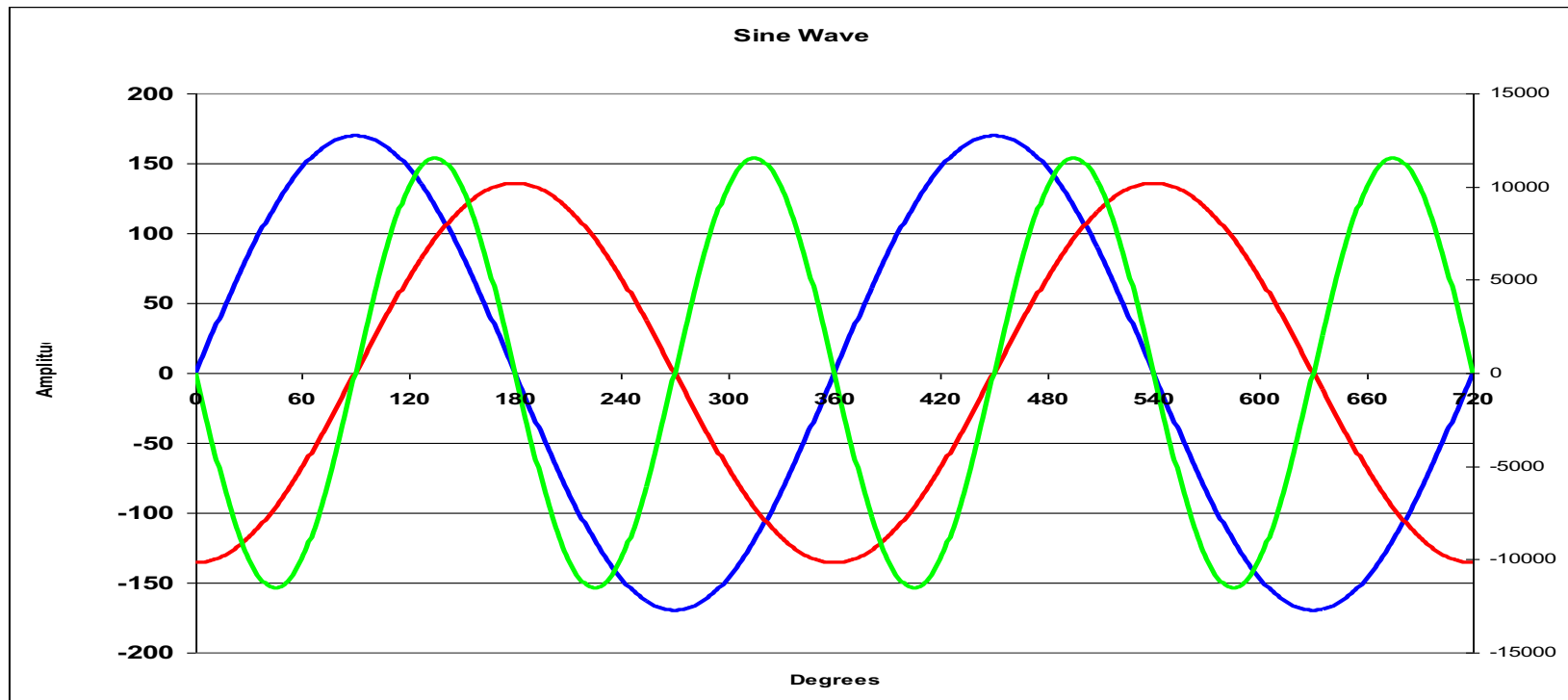

An inductive load consumes receives and delivers equal amounts of power, so the net active power (Watts) is ZERO
And the reactive load is 100%!

Capacitive Load

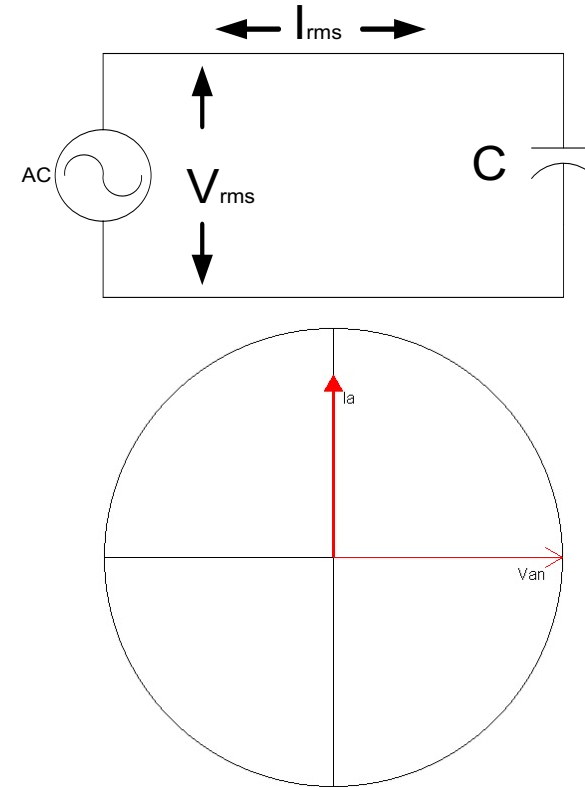
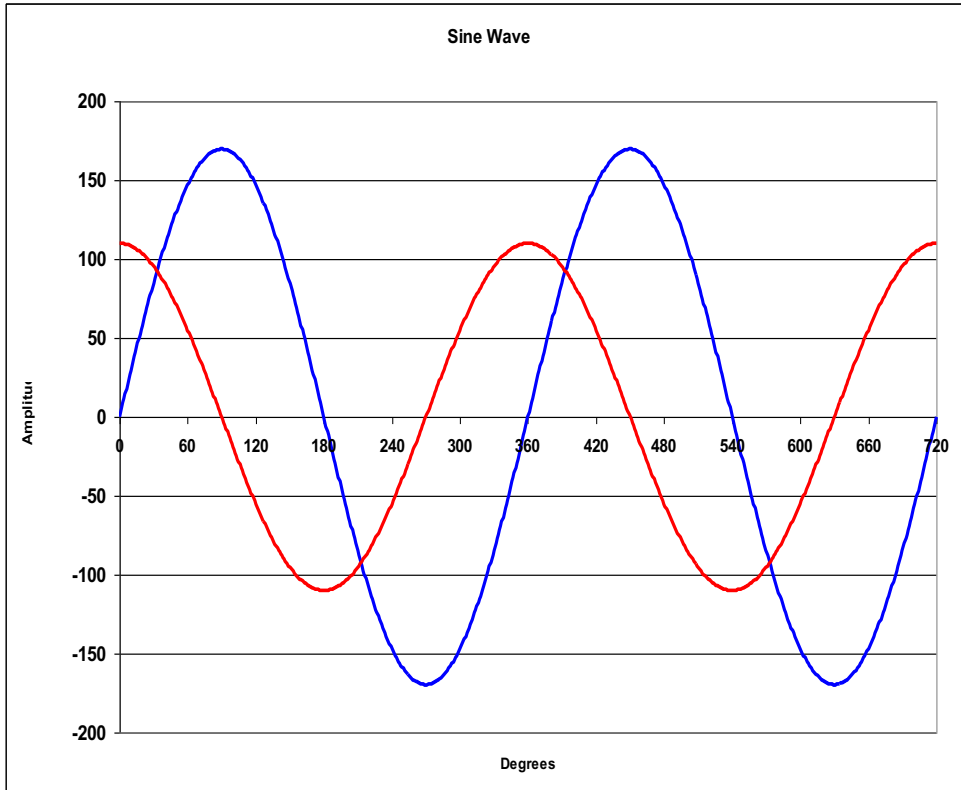

A purely capacitive load has -90° phase angle. Counter-clockwise vectors are **LEADING** as current leads voltage.

Capacitive Load

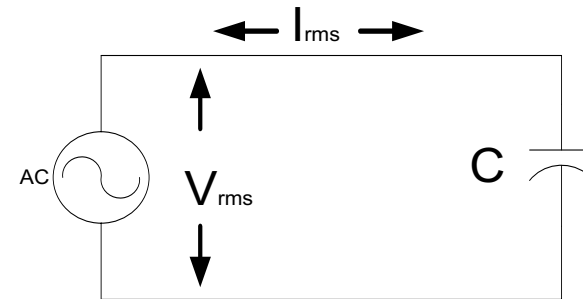
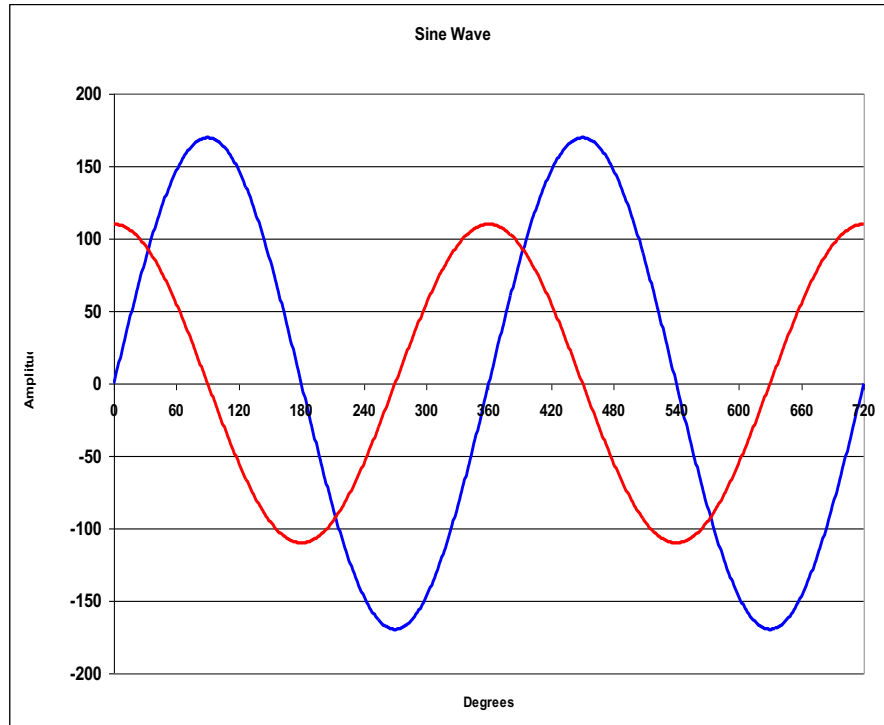

Inductive Example:

$$V = 120V$$

$$I = 10A$$

$$\Theta = -90^\circ$$

$$\text{Cos } -90^\circ = 0$$

$$\text{Sin } -90^\circ = -1$$

$$\text{Active Power (W)} = V I \cos (\theta) = 120 * 10 * 0 = 0 W$$

$$\text{Reactive Power (VAR)} = V I \sin (\theta) = 120 * 10 * -1 = -1200 \text{ VAR}$$

$$\text{Apparent Power (VA)} = V I = 120 * 10 = 1200 \text{ VA}$$

$$\text{PF} = W / \text{VA} = \cos (\theta) = 0$$

Capacitive Load

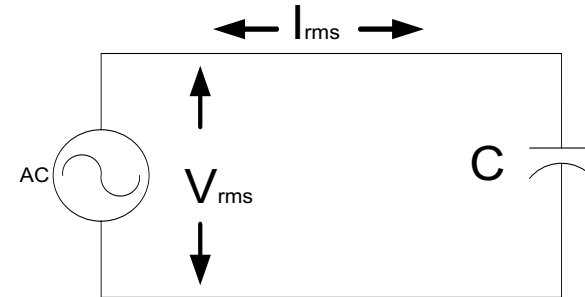
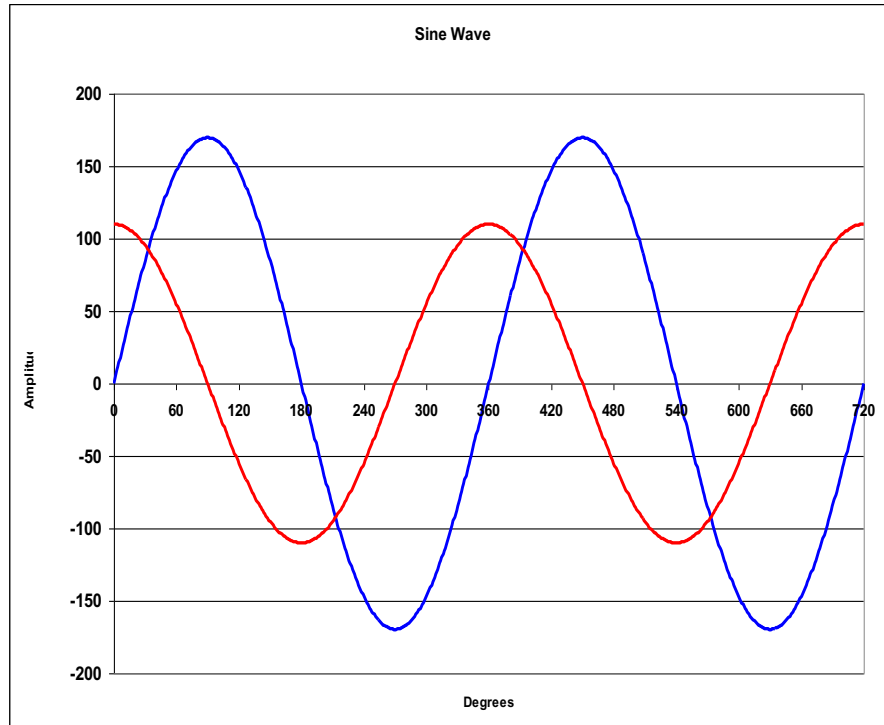

A purely capacitive load will:

- Only create negative VARs
- Create NO Watts
- Have a PF = 0 and phase angle of 90° leading

AC Theory – Instantaneous Power

For a capacitive load: $p = vi = 2VI\sin(\omega t)\sin(\omega t + 90) = VI\sin(2\omega t)$

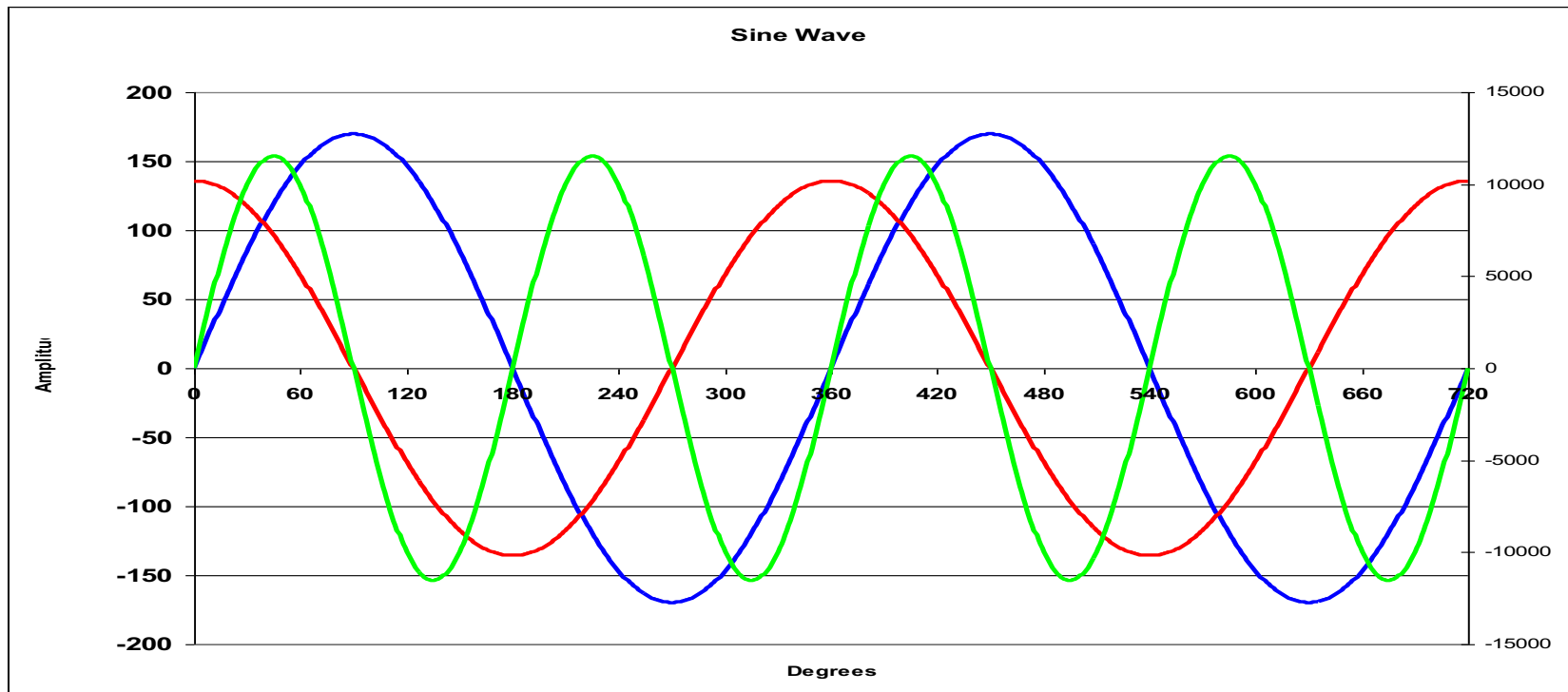

$$V = 120\sqrt{2}\sin(2\pi ft)$$

$$I = 96\sqrt{2}\sin(2\pi ft + 90)$$

$$P = 11520\sin(2\pi ft)$$

$P = 0$ Watts

Inductance Vs Capacitance

- More inductance creates more VAR, less W, and lower PF
- Capacitance is added to an inductive load to reduce VAR, raise W, and raise PF
- Ideally, we want all loads to have a PF = 1



+



=



Power Factor, Watts, and VARs

For a 120V, 10A System

Phase Angle	PF	Watts	VAR	VA
0	1	1200 W	0 VAR	1200 VA
30	0.866	1039 W	600 VAR	1200 VA
60	0.5	600 W	1039 VAR	1200 VA

As PF gets closer to 1, the Watt value gets closer to the VA value! This means more real power is being consumed!

3 Phase, 4-Wire “Y” Service

0° = Unity Power Factor

- Three Voltage Phasors
- 120° Apart
- Three Current Phasors
- Aligned with Voltage at PF=1

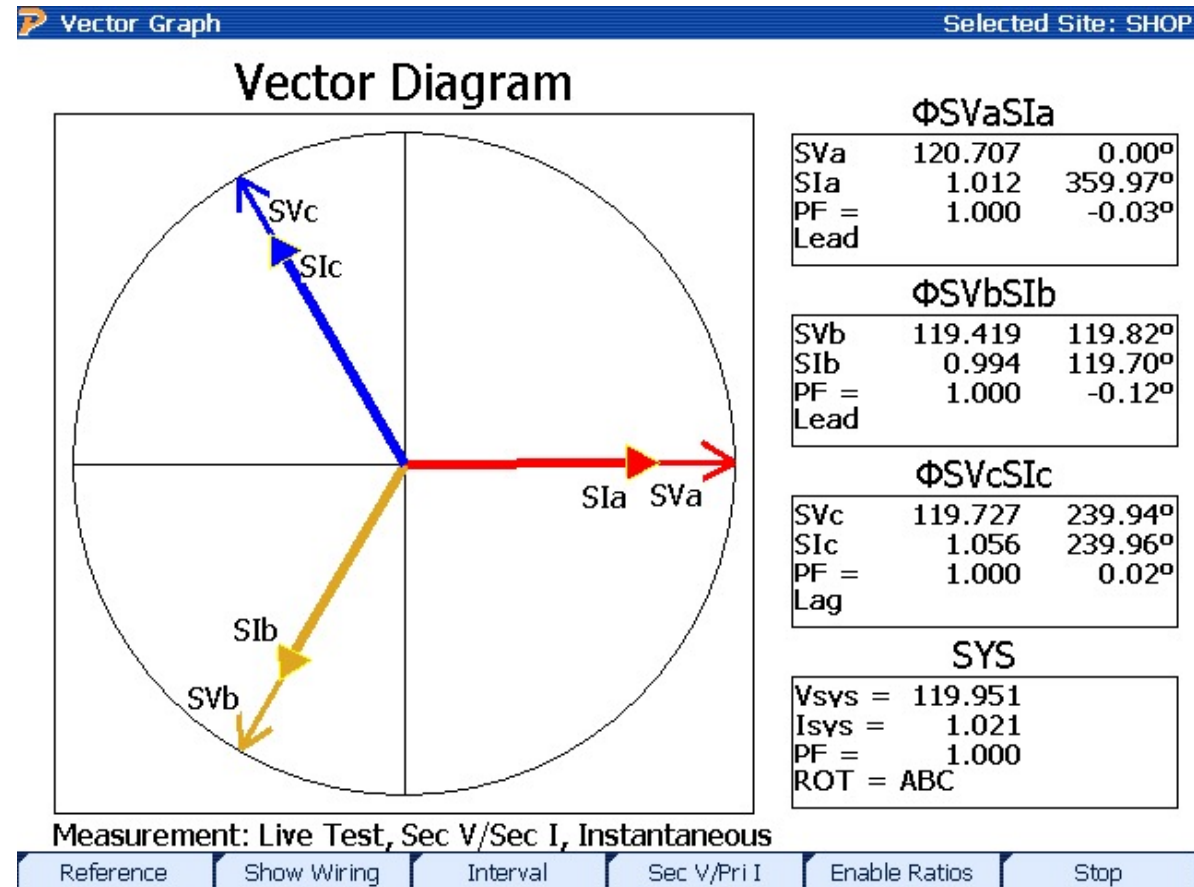

2 Phase, 3-Wire “Y” Service “Network Connection”

Single phase variant of the service.

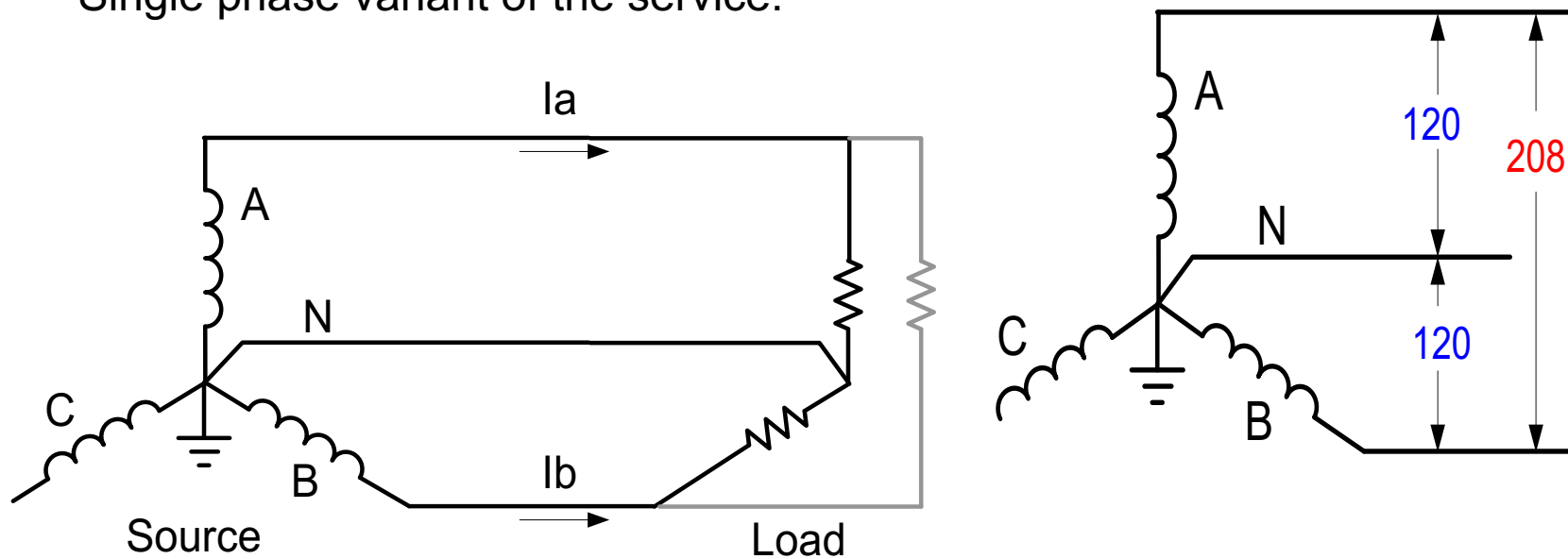

Two voltage sources with their returns connected to a common point.

Provides 208 rather than 240 volts across “high side” wires.

2 Phase, 3-Wire “Network” Service

- Two Voltage Phasors
- 120° Apart
- Two Current Phasors
- Aligned with Voltage at PF=1

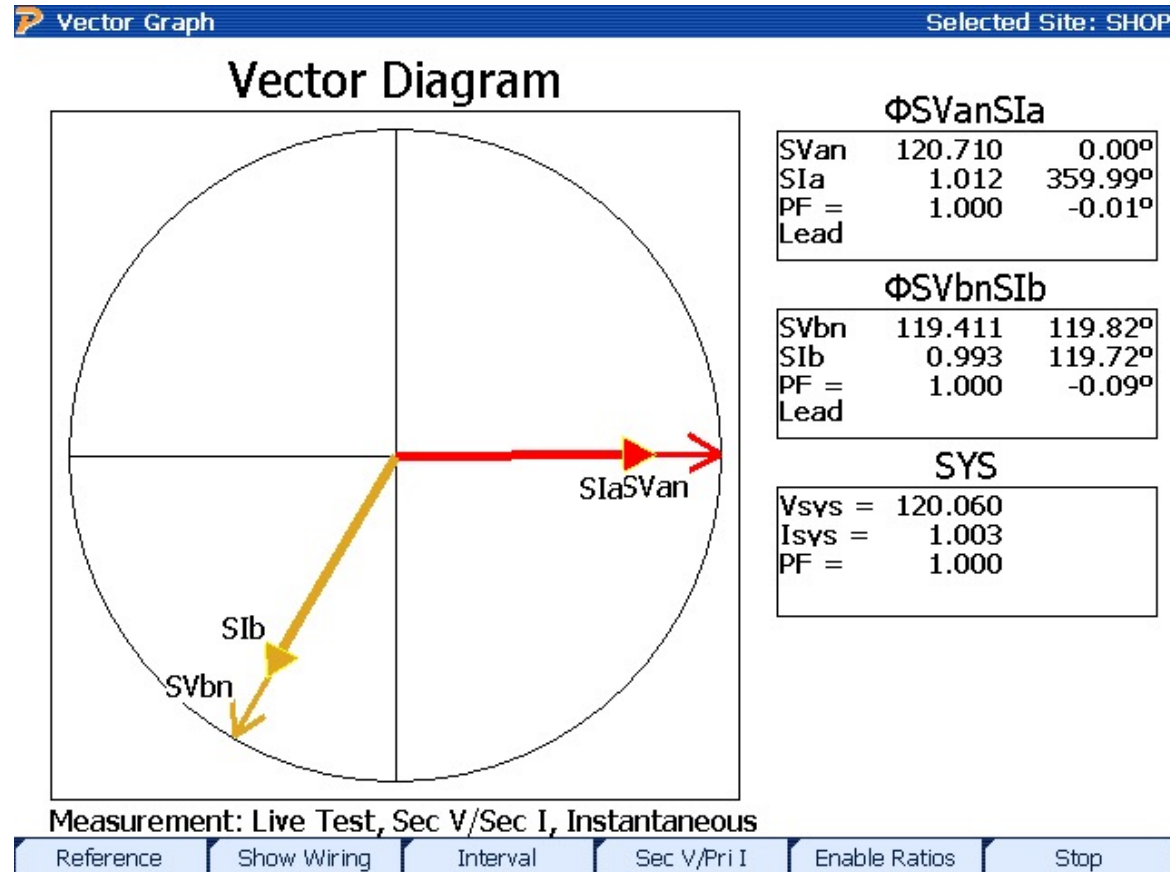

3 Phase, 3-Wire Delta Service

Common service type for industrial customers. This service has NO neutral.

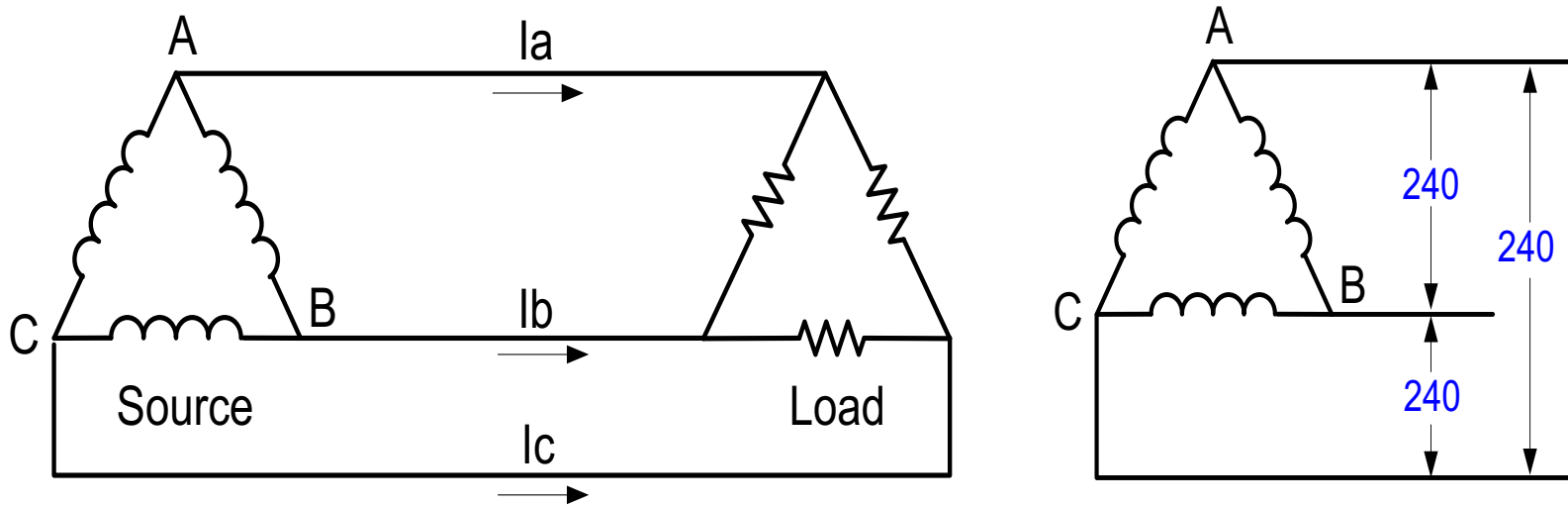

- Voltages normally measured relative to phase B.
- Voltage and current vectors do not align.
- Service is provided even when a phase is grounded.

3 Phase, 3-Wire Delta Service

Resistive Loads

- Two Voltage Phasors
- 60° Apart
- Two Current Phasors
- For a resistive load one current leads by 30° while the other lags by 30°

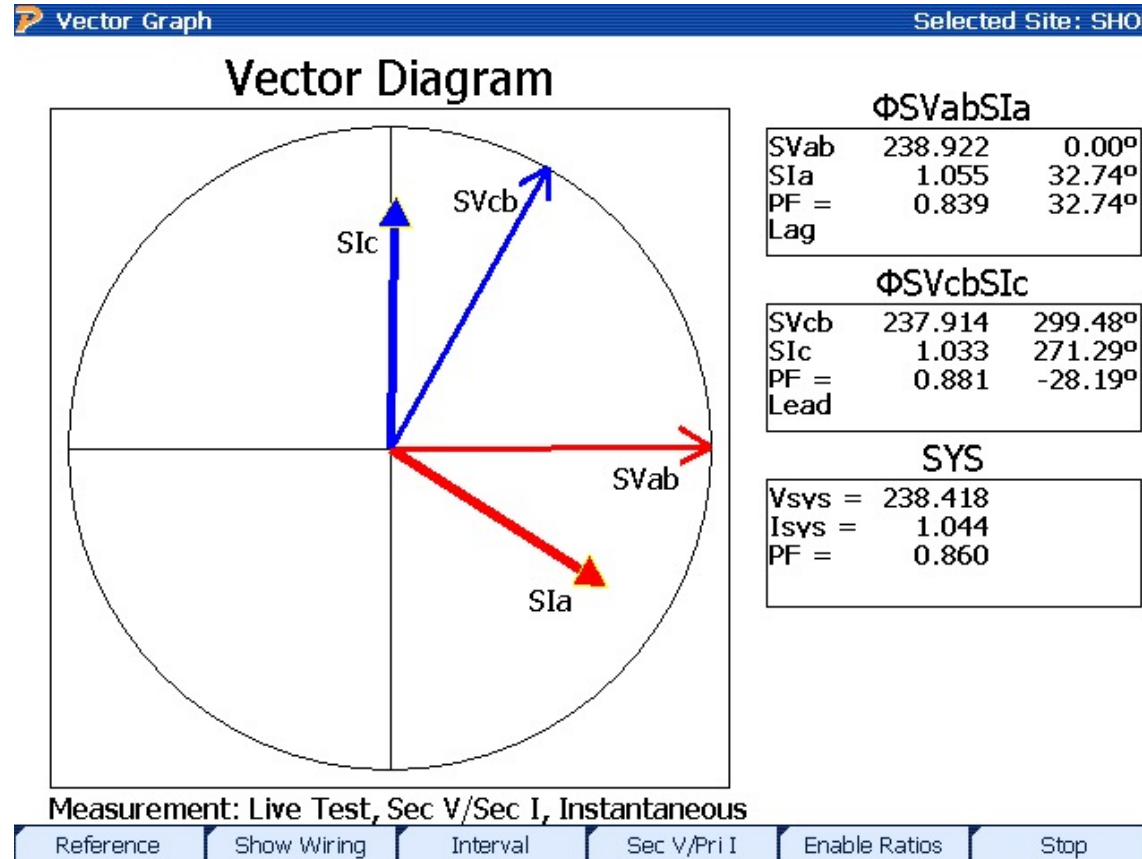

3 Phase, 3-Wire Delta Service

Understanding the Diagram

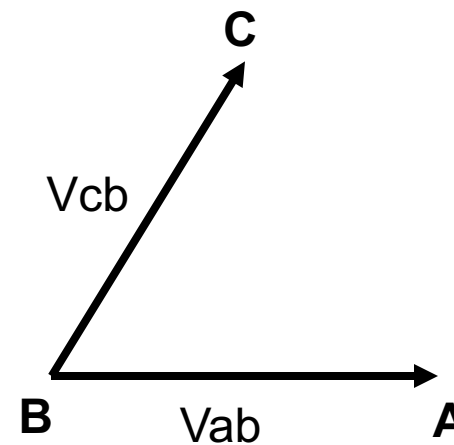
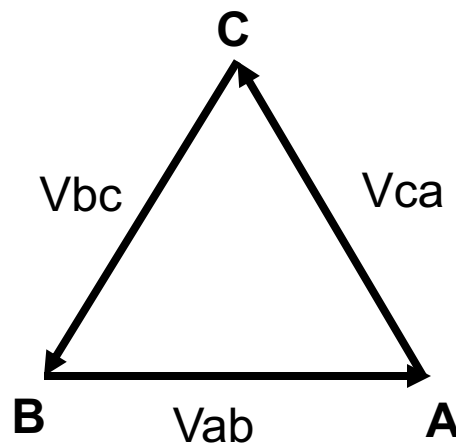
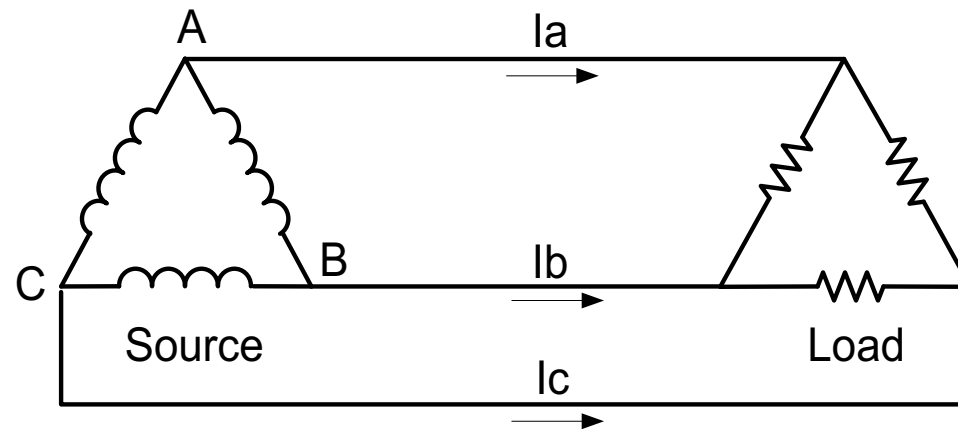

3 Phase, 3-Wire Delta Service

Understanding the Diagram

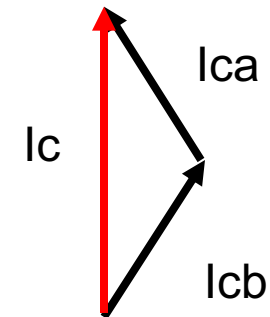
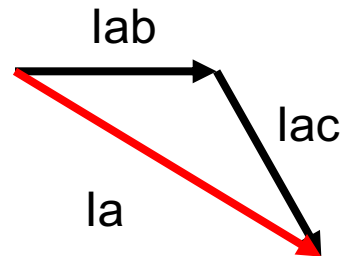
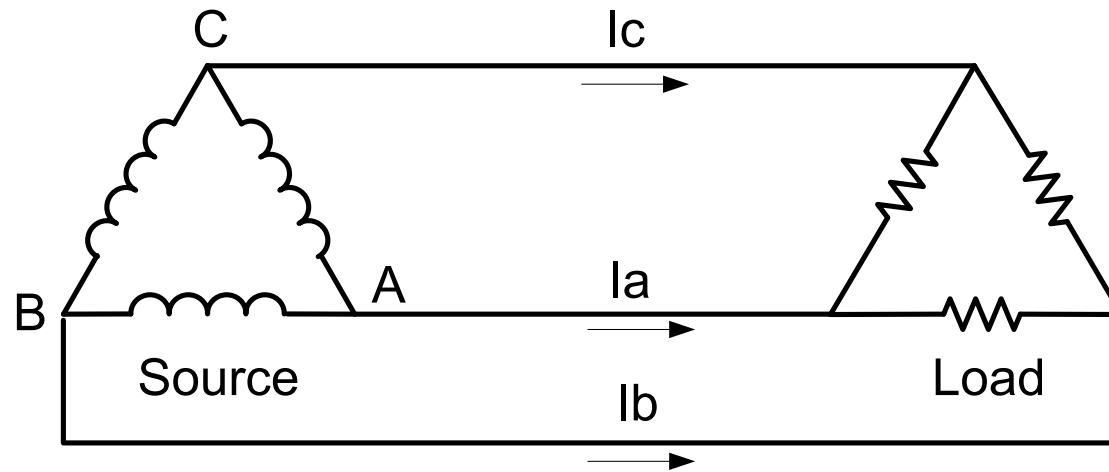

3 Phase, 3-Wire Delta Service

Resistive Load

- Two Voltage Phasors
- 60° Apart
- Two Current Phasors
- For a resistive load one current leads by 30° while the other lags by 30°

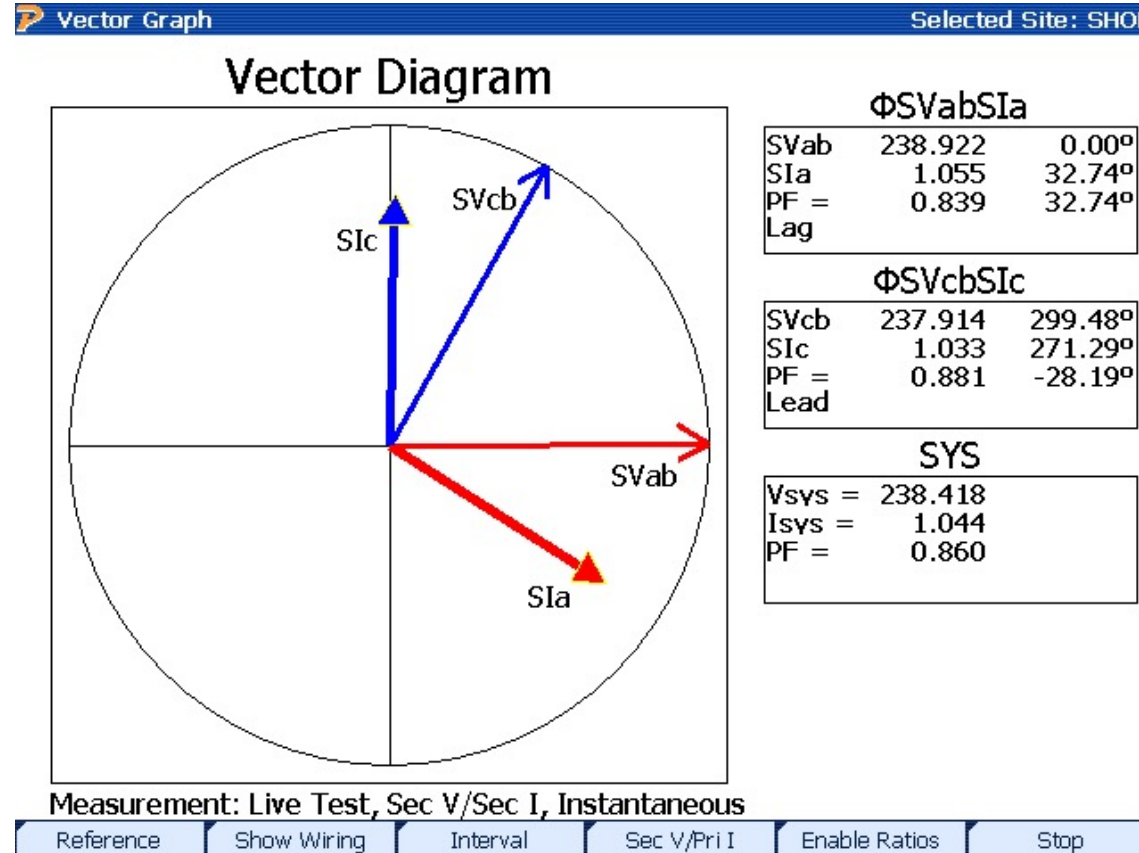

3 Phase, 4-Wire Delta Service

Common service type for industrial customers. Provides a residential like 120/240 service (lighting service) single phase 208 (high side) and even 3 phase 240 V.

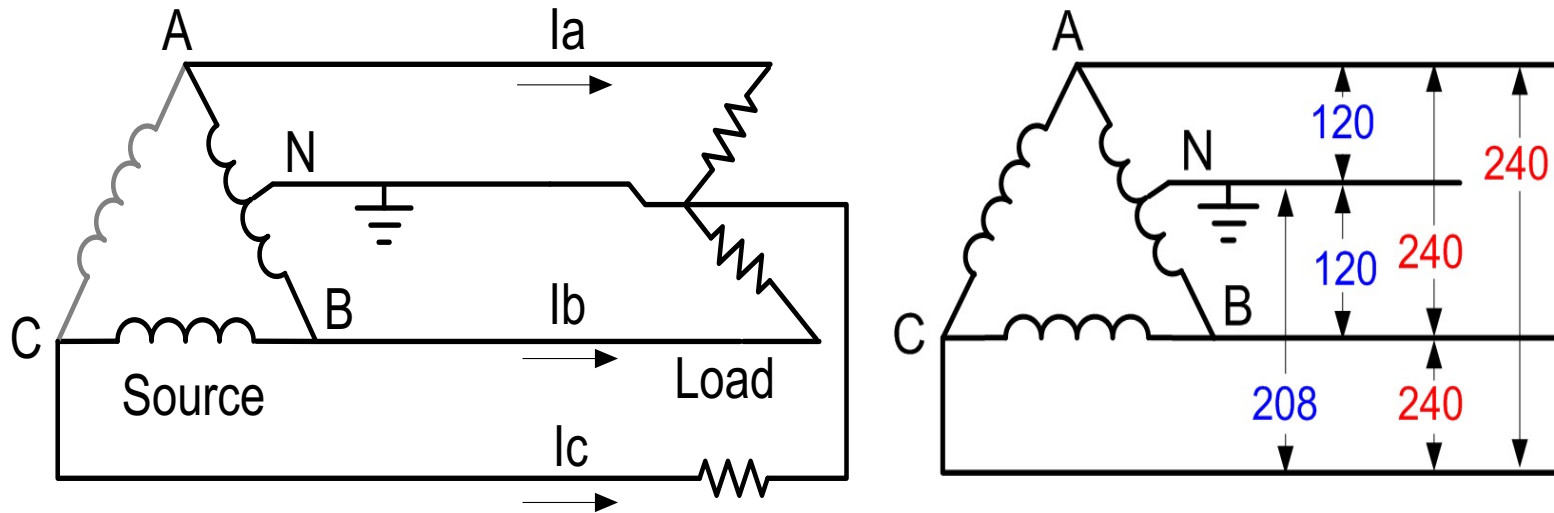

- Voltage phasors form a “T” 90° apart
- Currents are at 120° spacing
- In 120/120/208 form only the “hot” (208) leg has its voltage and current vectors aligned.

3 Phase, 4-Wire Delta Service

Resistive Load

- Three Voltage Phasors
- 90° Apart
- Three Current Phasors
- 120° apart

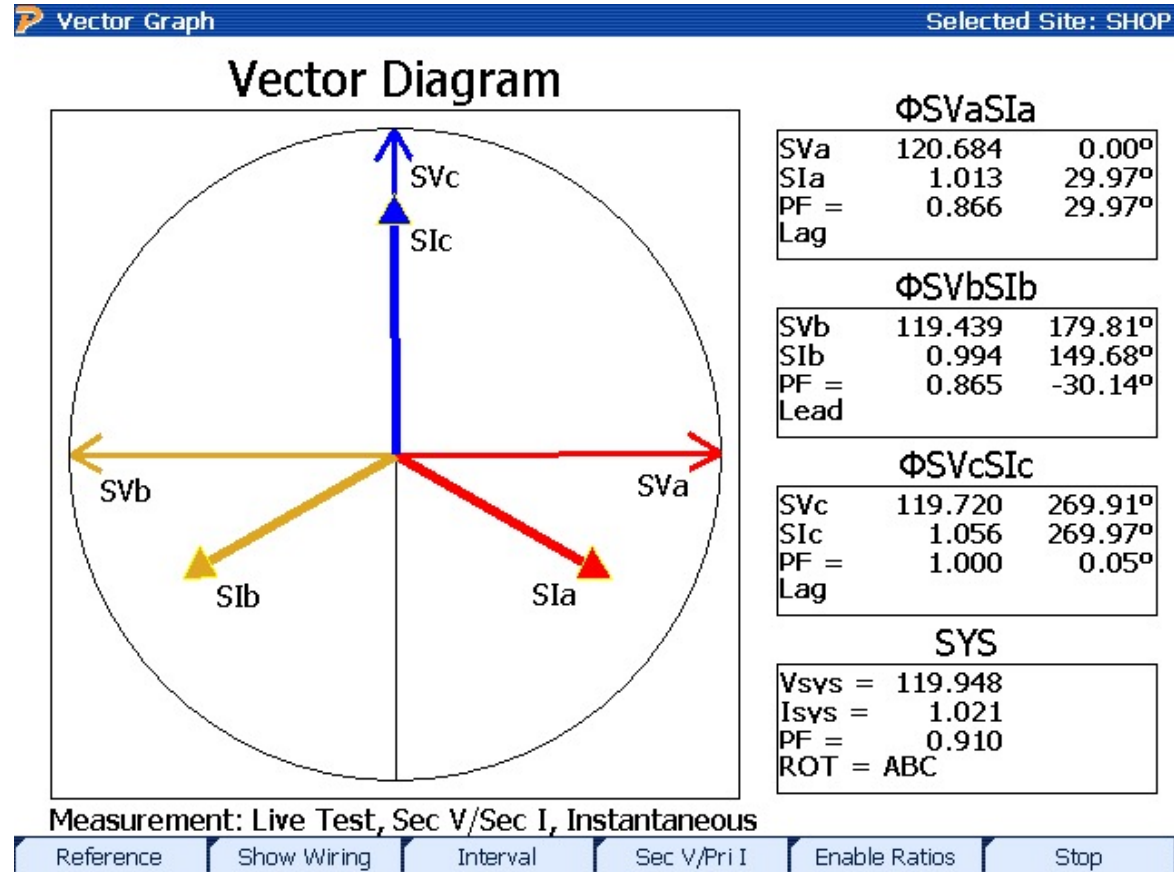

Troubleshooting with Vectors

What's Wrong?

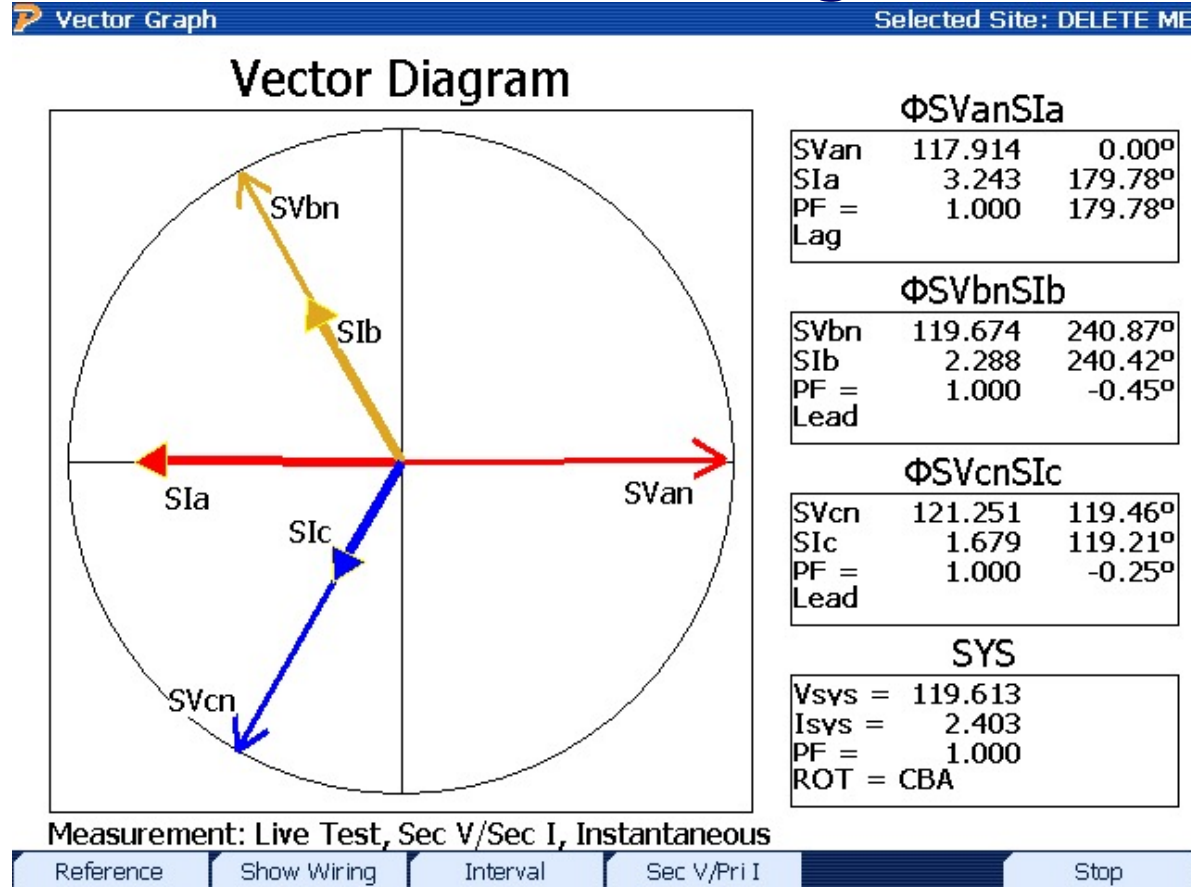

Phase A CT reversed.

Backwards CT = ??? \$\$\$

- $kW = V_a * I_a * \cos \theta + V_b * I_b * \cos \theta + V_c * I_c * \cos \theta$
- $\cos 180$ on phase A makes this **NEGATIVE** power!
- Reading will be 66% low assuming a balanced current load!

Troubleshooting with Vectors

What's Wrong?

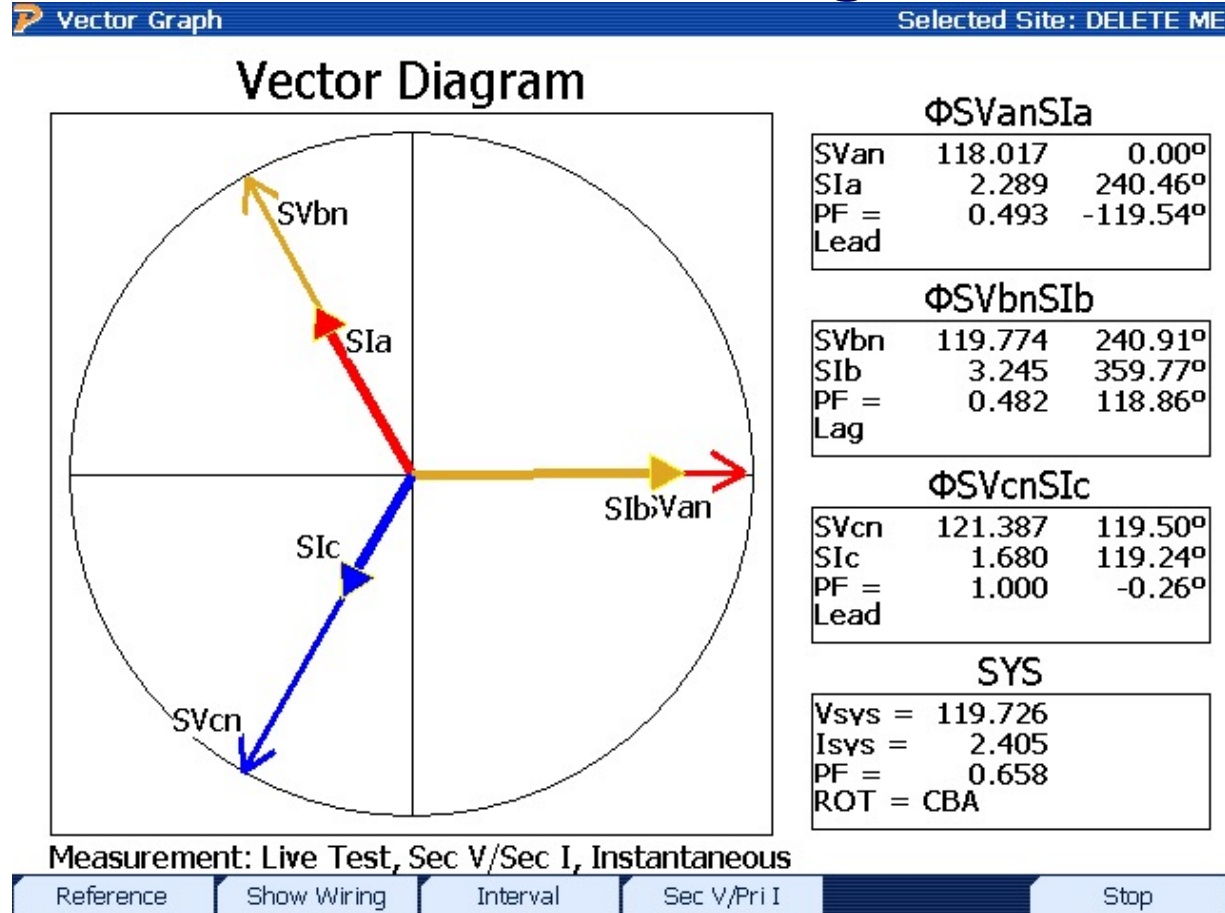

Phase A & B CTs swapped.

Swapped Wire = ??? \$\$\$

- $kW = V_a * I_a * \cos \theta + V_b * I_b * \cos \theta + V_c * I_c * \cos \theta$
- $\cos 120$ on phase A and B makes this **NEGATIVE** power!
- Reading will be 0W assuming a balanced current load!

Questions? Comments?

**Want a copy of this
presentation?**

Go to

powermetrix.com/presentations/

Thank you for your time!

