



Application Notes

3-Phase, 3Wire Delta (2V, 2C) TR Testing

Revision 1.1

Copyright Notice: Copyright © by TEC, 2013. All rights reserved.

Disclaimer

This documentation is provided for information purposes. TEC makes no warranty of any kind with regard to this material, including, but not limited to, the implied warranties of merchantability and fitness for a particular purpose. TEC shall not be liable for errors, omissions, or inconsistencies which may be contained herein or for incidental or consequential damages in connection with the furnishing, performance, or use of the material. Information in this document is subject to change without notice and does not represent a commitment on the part of TEC.

3-Phase, 3-Wire Delta (2V, 2C) TR

Service Type File:	S005F05
Meter Form:	5S, 5A, 35S, 45S
Meter Type:	Transformer Rated
Voltage:	120/240/480
Current Transformers:	2
Voltage Transformers:	2 (if applicable)
Blondel's Theorem Compliant:	Yes
MC Standard Drawings:	3301, 3302, 3303, 3307, 3308, 3309, 3310-1, 3310, 3311, 3312, 3313, 3314, 3315, 3317
© Model(s):	5300, 7300
Firmware:	1.0.1.5
App Note Revision:	1.2

Introduction

A common service type for industrial customers that has an inherently complex vector diagram is the 3-phase, 3-wire delta service. Because there are 3 conductors, the service is properly metered using a 2 element meter (Form 5). Note that the currents are measured directly from the source, but the voltages are shifted because they are measured using the phase B voltage as a reference.

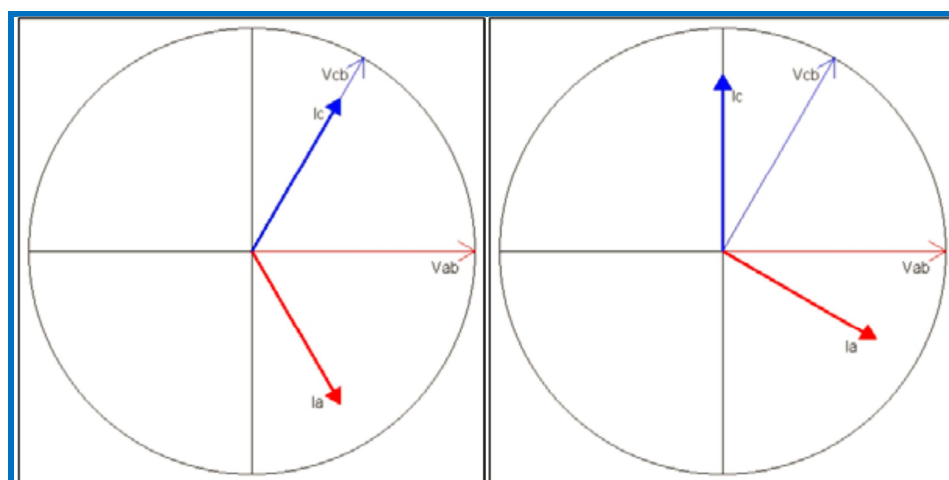

Figure 1: 30 Lag (0.866 PF)

Figure 2: No Lag (1.0 PF)

Required Equipment

Item	Qty.		Description	Part Number
1.	1		PowerMaster® Model 7300 or 5300	10-130-7300 or 10-130-5300
2.	1		3-Phase Test Switch Current Direct Probes	10-340-0027
3.	1		3-Phase Voltage Cable	10-340-0005
4.	1		3-Phase Probe Adapter Cable	10-340-0014
5.	1		36" Flexible Current Probe (600V, 3000A)	10-100-1036
6.	1		IR Pulse Detector	10-100-3327

Optional Equipment

The following equipment may be used as an alternate for the standard accessories:

Item	Qty.		Description	Part Number	Alternate for
7.	2		36" Flexible Current Probes (600V, 3000A)	10-100-1036	Item #5
8.	1		Amp LiteWire	SLWIDE-02	Item #5
9.	2		MN353 Clamp-On Probes	10-100-3353	Item #2
10.	2		MN375 Clamp-On Probes	10-100-3375	Item #2
11.	1		Form 5 Meter Base Test Adapter	75-310-0008	N/A
12.	1		Isolated KYZ Contact Pickup	10-120-0005	Item #6

13.	1		Photo Disk Detector	10-100-3326	Item #6
-----	---	---	---------------------	-------------	---------

Miscellaneous Equipment

- Personal Protective Equipment (PPE)
- Hot Stick (if using the Amp LiteWire)
- Cloth or rag to prevent possible sunlight when using the IR Pulse Detector

Procedure

1. Power up the PowerMaster[®] by pressing the ON key.



- From the PowerMaster[®], connect the 3-Phase Test Switch Current Direct Probes to CURRENT, and the 3-Phase Voltage Cable to VOLTAGE

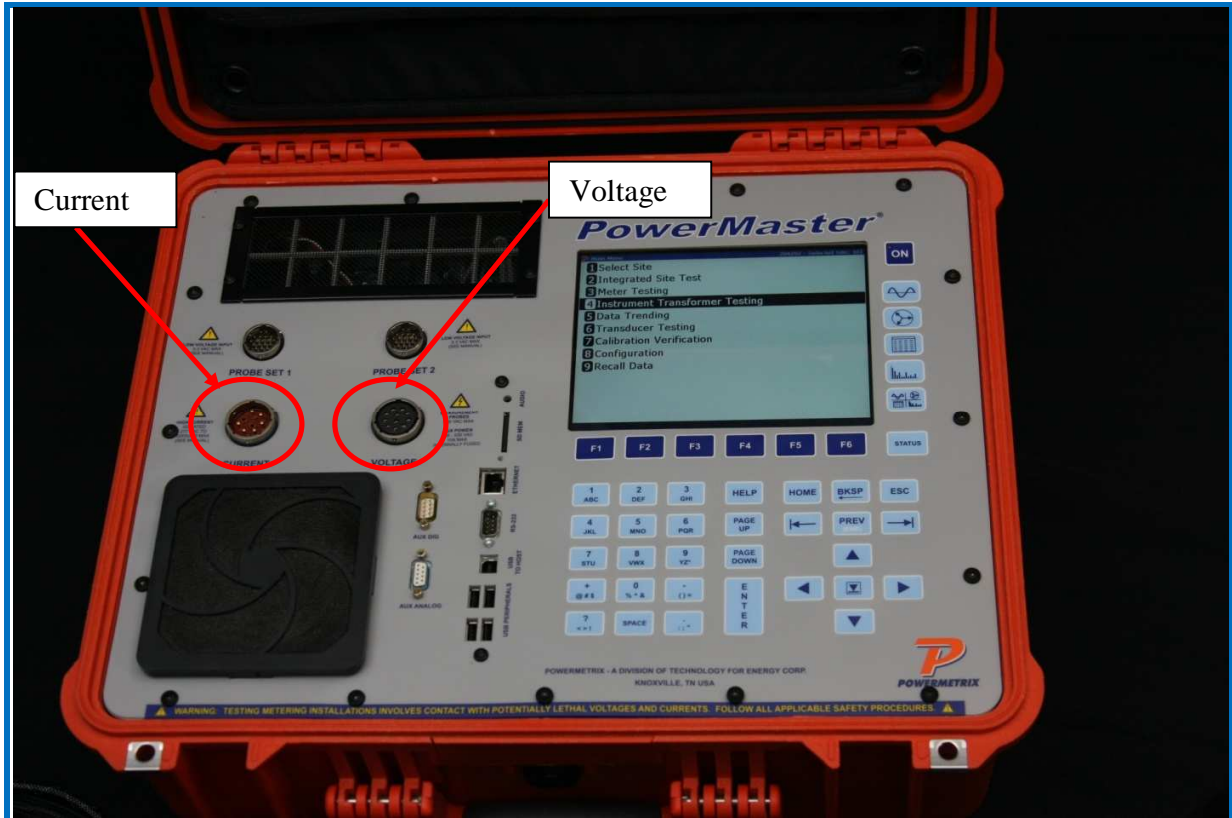

3. Connect the 3-Phase Probe Adapter Cable to PROBE SET 1. Connect the 36" Flexible Current Probe (600V, 1000A) to the adapter cable end for A phase (red).

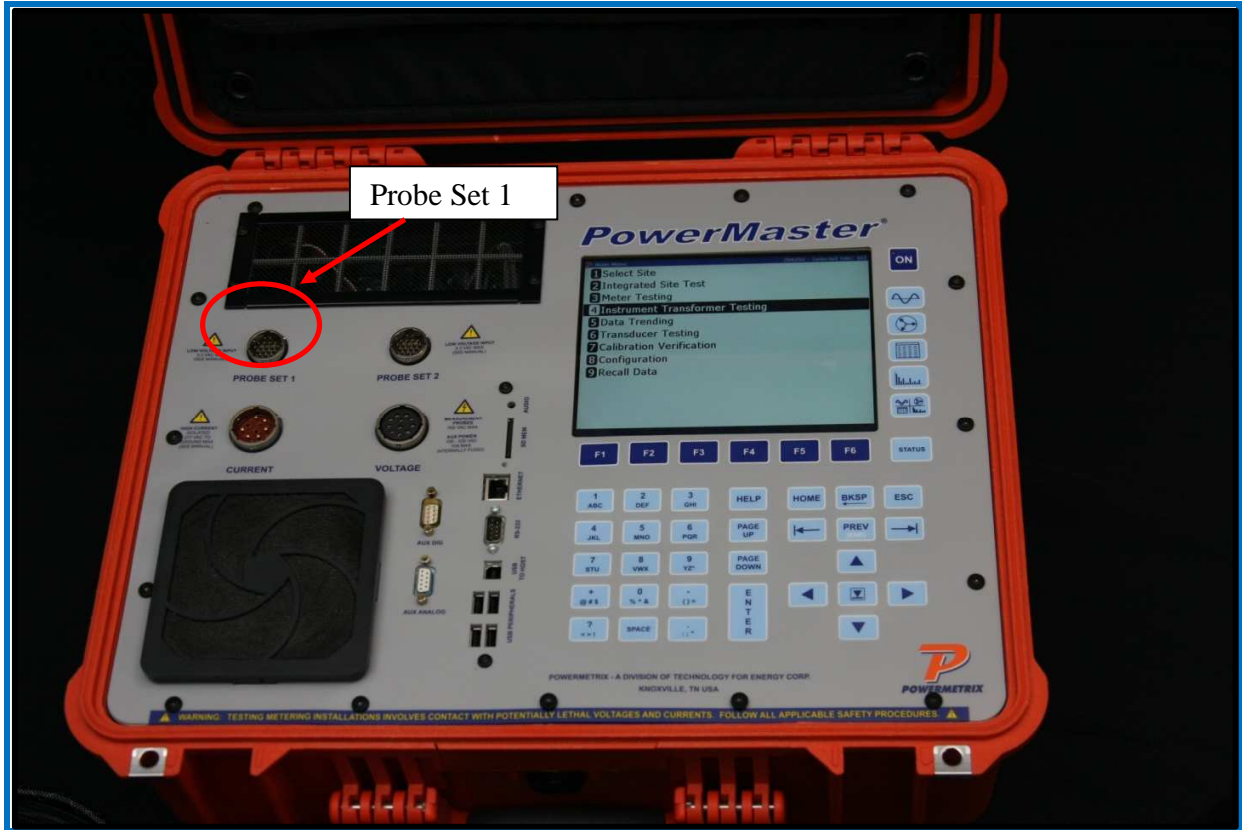

4. Connect the 3-Phase Voltage Cable leads to the potentials of the test switch according to the wiring diagram shown below (A=red, C=blue, Reference = yellow, Neutral (white) and Ground (green) tie to earth ground).

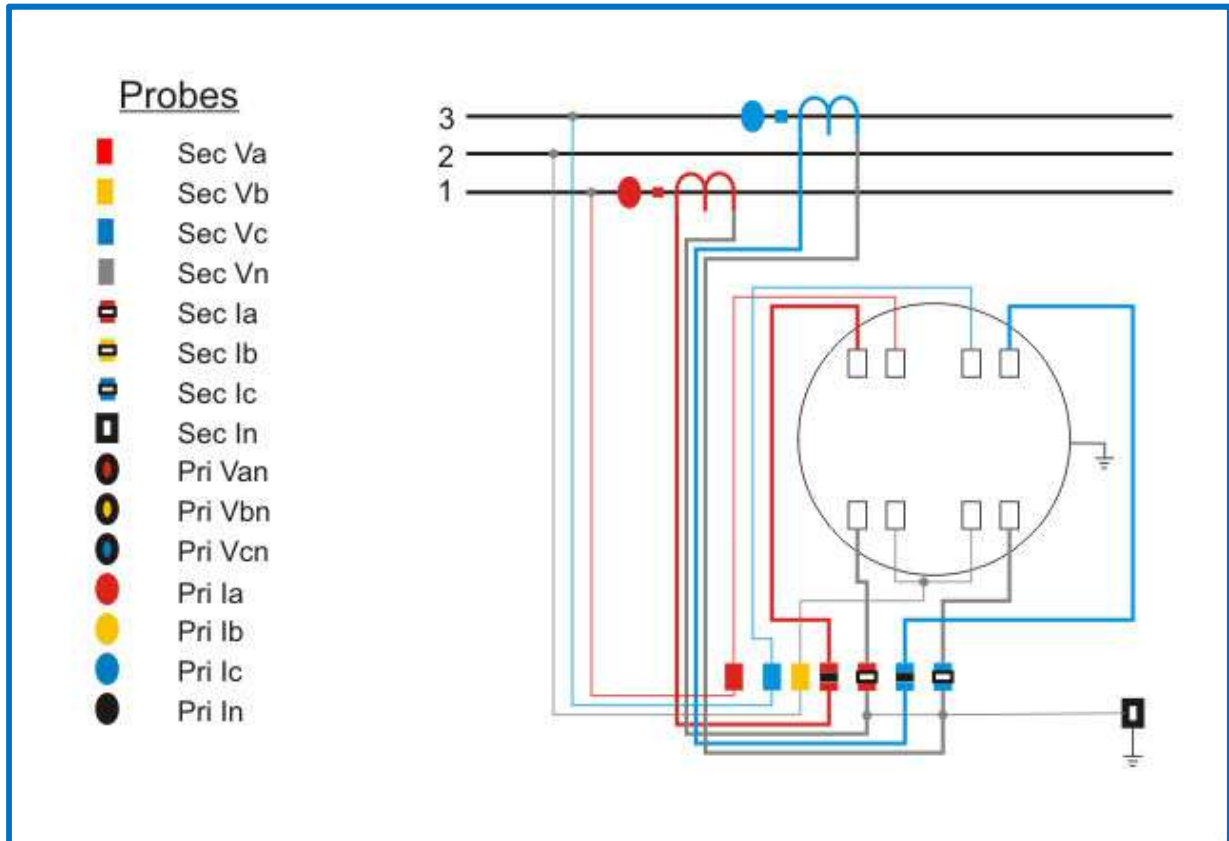

5. Connect the Auxiliary Power leads to a voltage source between 100-530Vac.
6. Insert the 3-Phase Test Switch Current Direct Probes into the current return of the test switch according to the wiring diagram shown in "Equipment Hookup" (A=red, C=blue). For polarity, the white side should face up (towards the base of the meter). For safety, shunt the CT current *before* inserting the probes. After insertion, re-engage the CT currents.

7. On the PowerMaster[®], on the main screen Press “1” to select a site.

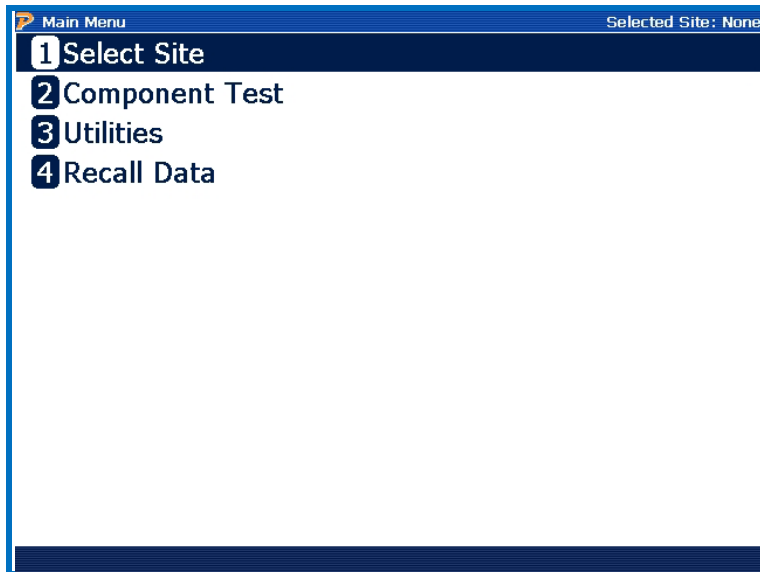

8. View the available sites. If the site is present either from being created in Meter Site Manager or created locally, select it and proceed to Step 12. Press “F2” to create a new Site.

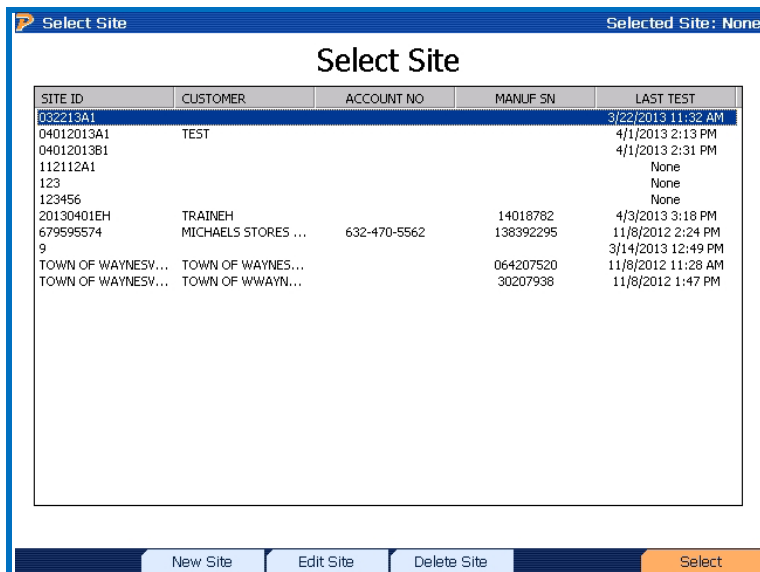

9. Once in the Site Editor, enter a unique Site ID, select the Meter Form (either a 5, 35, or 45), then using the drop down menu, select the Service Type as S005F05. Verify that the “Service” field is 3W-Delta.

Site Editor Selected Site: None

Site ID: 12345

Meter Form: 5

Service: 3W-DELTA

Service Type: 3-Phase, 3-Wire Delta (2V, 2C) TR - S005F05

Test Setup: Default 1

Customer:

Account No:

Address 1:

Address 2:

City:

State/Prov: Zip:

Country:

Substation:

Billing Mult:

Phone:

Locator:

Pri Volts:

Next Test: 2013 Oct 04

Note: Enter Kt here to override the value from meter selection on Page 2.

Kt:

Section | Next Page

- Tab to “Test Setup,” and select the appropriate setup for this installation. To create or edit a setup, press F4. For detailed information about the “Test Setup,” refer to Section 7.4.1.1 in the User Manual (revision 1.3).

Site Editor Selected Site: None

Site ID: 12345 Kt:

Meter Form: 5 Note: Enter Kt here to override the value from meter selection on Page 2.

Service: 3W-DELTA

Service Type: 3-Phase, 3-Wire Delta (2V, 2C) TR - S005F05

Test Setup: Default 1
 CT B+R; CL + 5A FLPFL + EL WH
 Default 1
 Default 2
 TES
 Test with two wraps

Customer: Substation:

Account No: Billing Mult:

Address 1: Phone:

Address 2: Locator:

City: Pri Volts:

State/Prov: Zip: Next Test: 2013 Oct 04

Country:

Section Next Page Test Editor

- Enter all other relevant fields in the Site Editor (required fields are in yellow). For detailed information about the Site Editor, refer to Section 7 in the User Manual (revision 1.3). Press F6 (Save and Exit) to continue.

Site Editor Selected Site: None

Site ID: 12345 Kt: 1.8 Note: Enter Kt here to override the value from meter selection on Page 2.

Meter Form: 5

Service: 3W-DELTA

Service Type: 3-Phase, 3-Wire Delta (2V, 2C) TR - S005F05

Test Setup: Default 1

Customer: Substation:

Account No: Billing Mult:

Address 1: Phone:

Address 2: Locator:

City: Pri Volts:

State/Prov: Zip: Next Test: 2013 Oct 04

Country:

Section Next Page Save & Exit

12. Exiting the Site Editor returns you to the Site listing menu. Select the site you are going to use (the highlighted one), and press F6 (Select).

SITE ID	CUSTOMER	ACCOUNT NO	MANUF SN	LAST TEST
032213A1				3/22/2013 11:32 AM
04012013A1	TEST			4/1/2013 2:13 PM
04012013B1				4/1/2013 2:31 PM
112112A1				None
123				None
123456				None
20130401EH	TRAINEH		14018782	4/3/2013 3:18 PM
679595574	MICHAELS STORES ...	632-470-5562	138392295	11/8/2012 2:24 PM
9				3/14/2013 12:49 PM
TOWN OF WAYNESV...	TOWN OF WAYNES...		064207520	11/8/2012 11:28 AM
TOWN OF WAYNESV...	TOWN OF WWAYN...		30207938	11/8/2012 1:47 PM

Buttons at the bottom: New Site, Edit Site, Delete Site, Select

13. Enter any information needed on this screen then press “F6” to continue.

Technician Name:

Technician Name:

Site Instructions and Information

Your Comments and Notes Regarding This Testing Session

Buttons at the bottom: Cancel, Continue

14. This is the main menu. Any actions performed on this screen will be carried out for the site that is currently selected (to deselect the site, Press “6”). Press “2” to review and begin the “Integrated Site Test”.

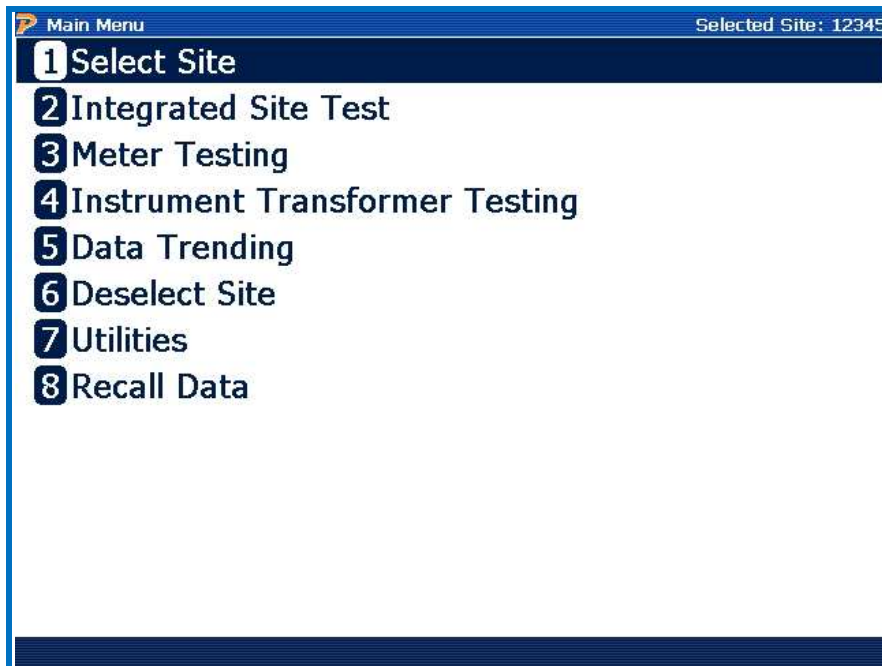

15. Looking at the “Integrated Site Test” menu, review and confirm the test setup. Press “F6” to continue. It is possible to edit this form, but any revisions will not be saved.

16. The PowerMaster® will confirm if the probes and lead sets are detected for the meter test.

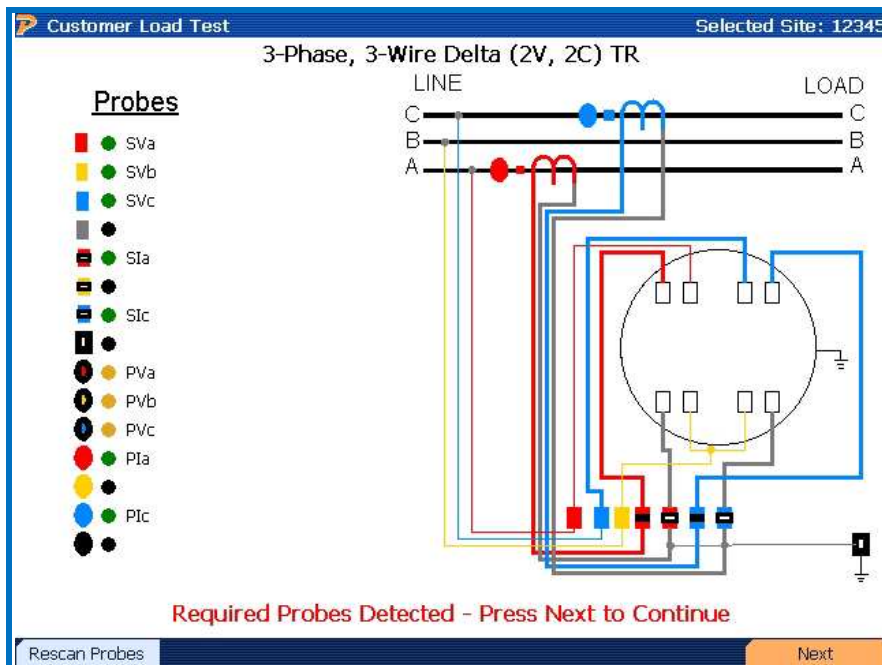

17. Install the IR Pulse Detector onto the meter and connect it to AUX DIGITAL on the PowerMaster®. Press F6 to continue.

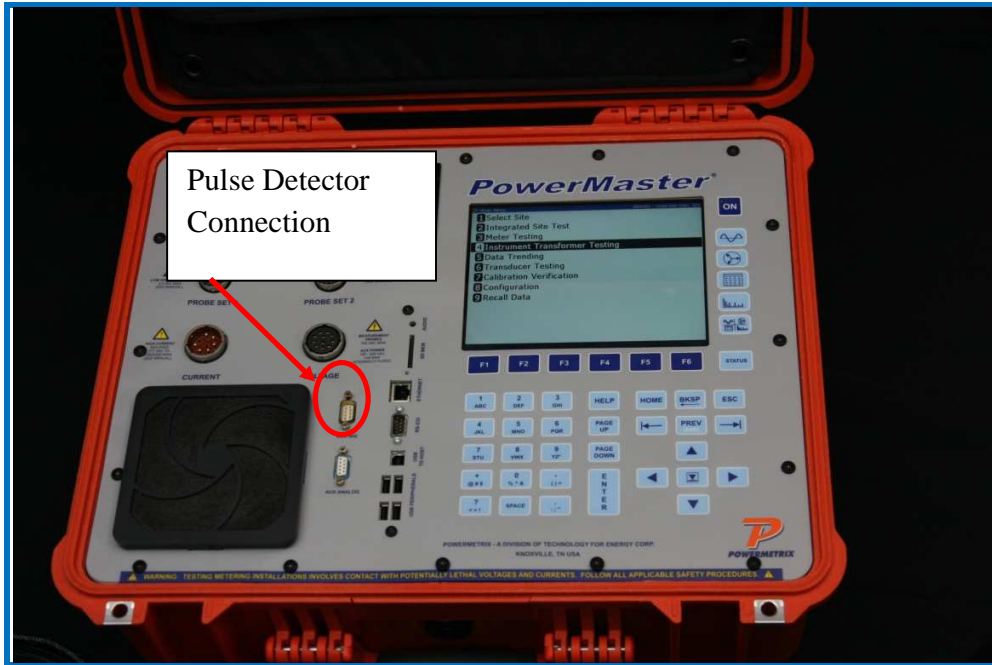

18. The PowerMaster® will now check for valid signals for the voltages and currents for the meter test. Next, it will check for meter pulses. After meter pulses are detected, press “F6” to continue.

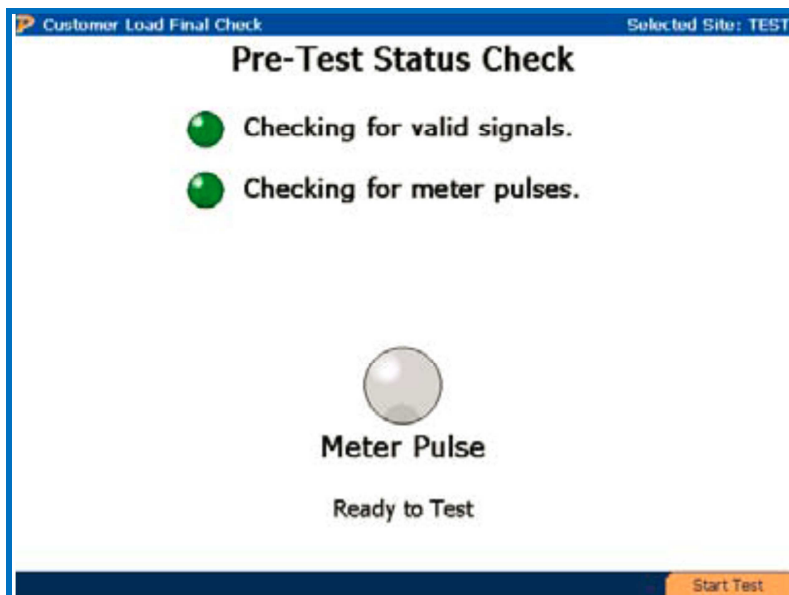

19. After the customer load meter test is complete, review the results. If outside the tolerance, press F1 to restart. If within tolerance, press F6 to continue.

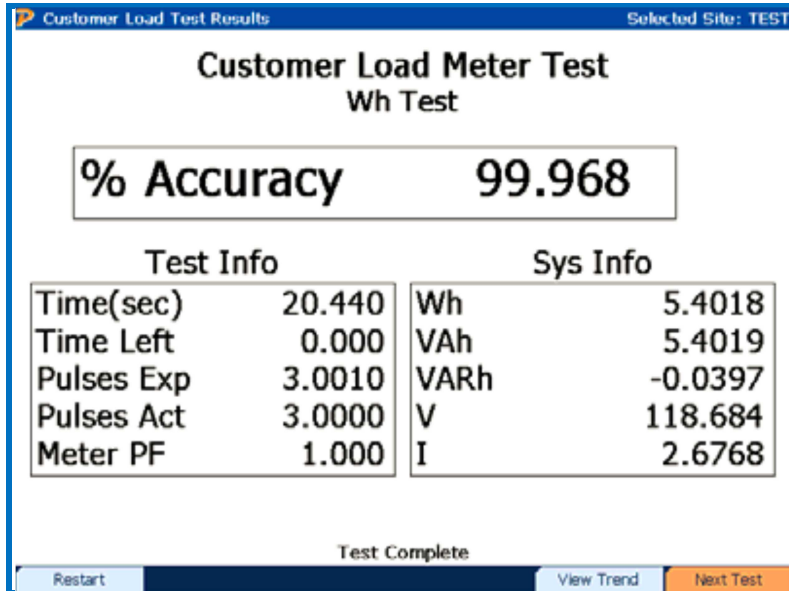

20. The PowerMaster® will confirm if the probes and lead sets are connected properly for the CT test.

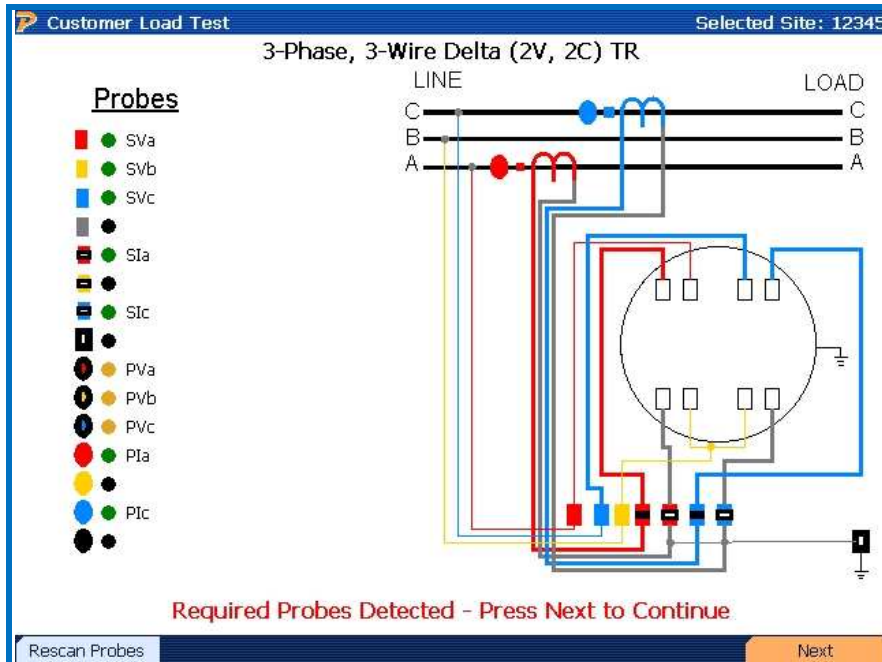

21. Wrap the 36" Flexible Current Probe (600V, 3000A) around all of the primary conductors for A phase CT. An arrow on the connector denotes polarity (arrow towards load). Press F6 to proceed with the test.



22. Press F6 to begin the CT Ratio test on Phase A.

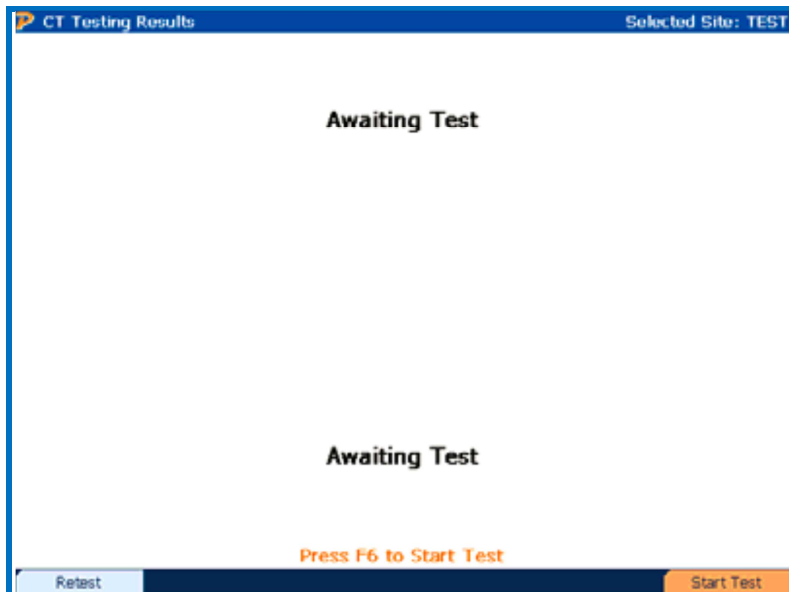

23. View results for the Phase A CT test. If a re-test is desired, Press “F1” to Re-test. To begin the testing for the Phase C CTs, wrap the 36” Flexible Current Probe (600V, 3000A) around all of the primary conductors for the Phase C CT. Press F6 to continue.

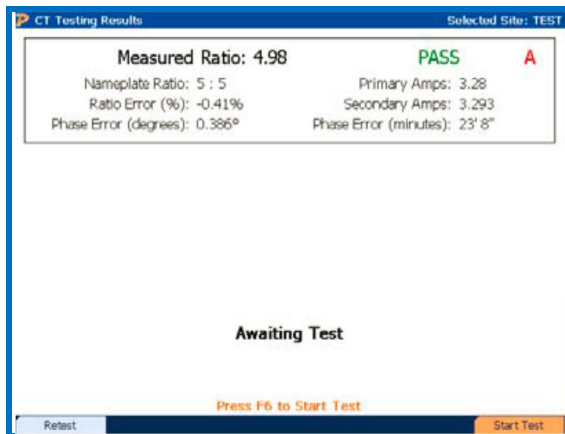

24. View results for Phase C CT. Press F6 to complete the test. At this point there are the following options available:

- F1: Retest Phase C
- F2: Re-test both CT's (return to step 20)
- F4: Views graphs or F5 to view the data
- F6: Finish testing and return to the main menu.

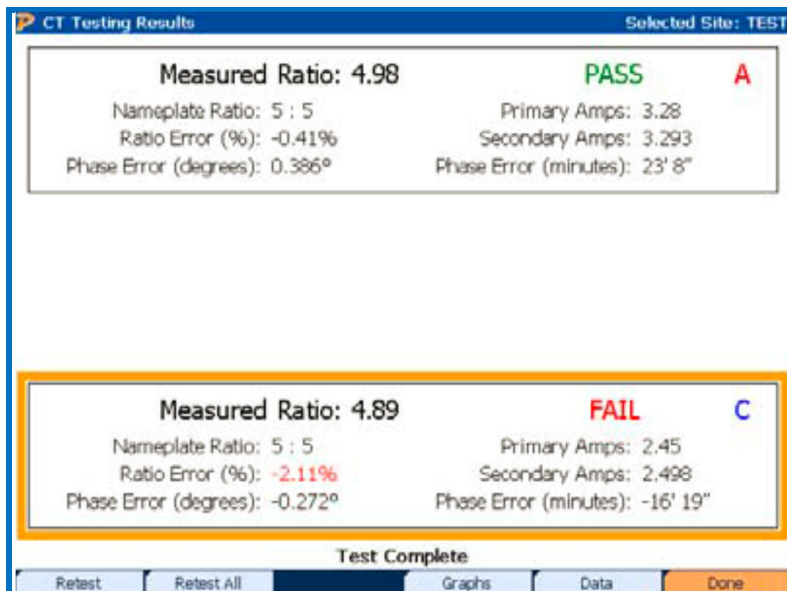

25. At the Main Menu, select and press Enter for “Recall Data”, or press the number “8”.

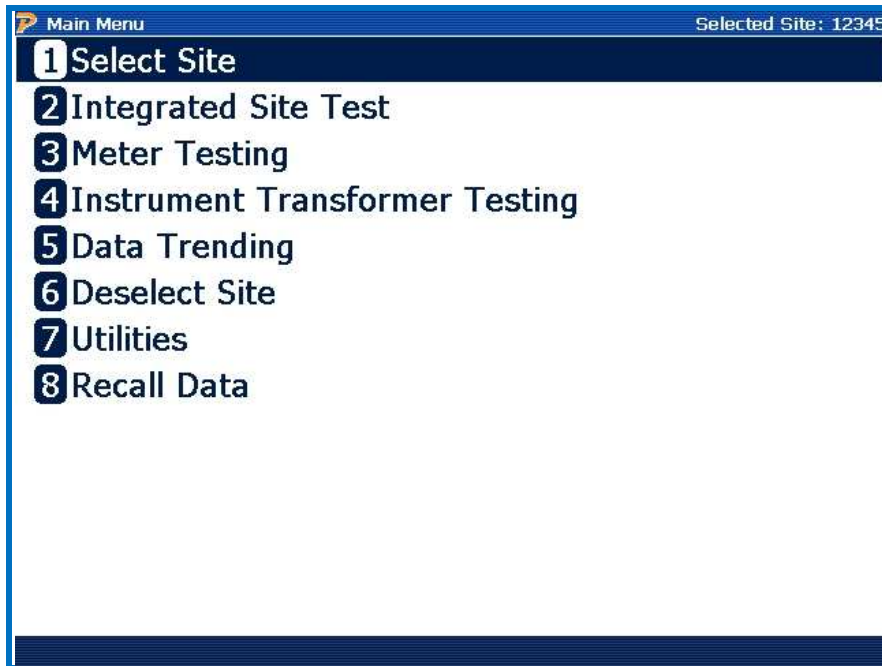

26. Select the site that was tested and review the data before leaving the site. Use up and down arrows to select the site and F6 to expand and view the data. After review is complete, power off the PowerMaster[®] by pressing the ON key.

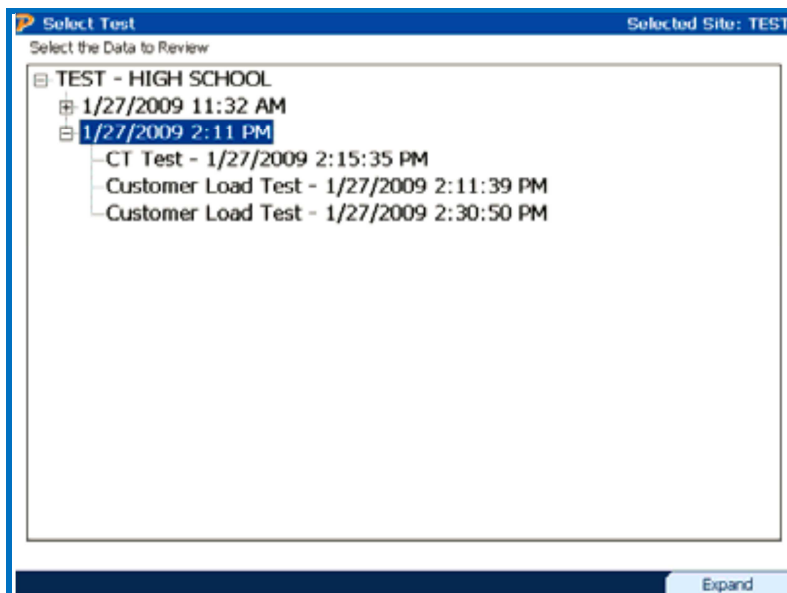

27. Carefully disconnect all lead sets and probes and properly store them in the accessory case.

Using Optional Equipment

Procedure Using the Amp LiteWire

1. Power up the PowerMaster[®] by pressing the “ON” key.
2. From the PowerMaster[®], connect the 3-Phase Test Switch Current Direct Probes to CURRENT, and the 3-Phase Voltage Cable to VOLTAGE.
3. Connect the 3-Phase Probe Adapter Cable to PROBE SET 1. Connect the HV Signal Cable to A phase (red) of the 3-Phase Probe Adapter Cable.
4. Connect the HV Signal Cable to the “Analog Output” (BNC) connector on the Amp LiteWire receiver. Connect the male ends of the orange fiber optic cable to the female ends of the transmitter and receiver (for detailed instructions, refer to the Amp LiteWire Operators Manual). Carefully lay the Amp LiteWire aside.
5. Follow the procedure through steps 4-18 as normal.
6. Use the Amp LiteWire’s chuck adapter to connect to a hot stick. Turn on the Amp LiteWire by first turning on the receiver (press 2x) then the transmitter (press 2x). Once both modules are powered on, the receiver will display 0.
7. Carefully lift the Amp LiteWire into the A phase CT conductors. For polarity, position the face of the transmitter to the load side of the CT.
8. Press F6 to test the Phase A CT.
9. View results for Phase A CT. Carefully lift the Amp LiteWire into the Phase C CT conductors. Press F6 to continue.
10. Follow the procedure through steps 22-26 as normal.

Procedure Using the MN353 or MN375 Clamp-On Probes

1. Power up the PowerMaster[®] by pressing the ON key.
2. From the PowerMaster[®], connect the 3-Phase Probe Adapter Cable to PROBE SET 1, and the 3-Phase Voltage Cable to VOLTAGE.
3. Connect the MN353 or MN375 probes to the ends of the 3-Phase Probe Adapter Cable for PROBE SET 1 (A = red, C = blue).

4. Connect the 3-Phase Voltage Cable leads to the potentials of the test switch according to the wiring diagram shown in "Equipment Hookup" (A=red, C=blue, Reference=yellow, Neutral (white) and Ground (green) should be connected to earth ground).
5. Clamp the MN353 or MN375 probes around the secondary current path of the meter installation according to the wiring diagram shown in "Equipment Hookup". An arrow on the probe denotes polarity (arrow towards load)
6. Connect the second 3-Phase Probe Adapter Cable to PROBE SET 2. Connect the 36" Flexible Current Probe (600V, 1000A) to the adapter cable end for A phase (red).
7. Follow the procedure through steps 7-25 as normal.

Procedure using the Form 5 Meter Base Adapter

1. Follow the procedure through steps 1-3 as normal.
2. Remove the meter from the meter socket. Place the meter into the Form 5 Meter Base Adapter. Firmly place the Form 5 Meter Base Adapter back into the meter base.
3. Connect the 3-Phase Voltage Cable leads to the potentials of the test switch (VA=red, VC=blue, VO=yellow, Ground=green and white).
4. Insert the 3-Phase Test Switch Current Direct Probes into the current return of the test switch according to the wiring diagram shown in "Fig. 1" (COA=red, COC=blue). For safety, shunt the CT currents (CA, CC) *before* inserting the probes. After insertion, re-engage the CT currents.
5. Follow the procedure through steps 7-26 as normal.

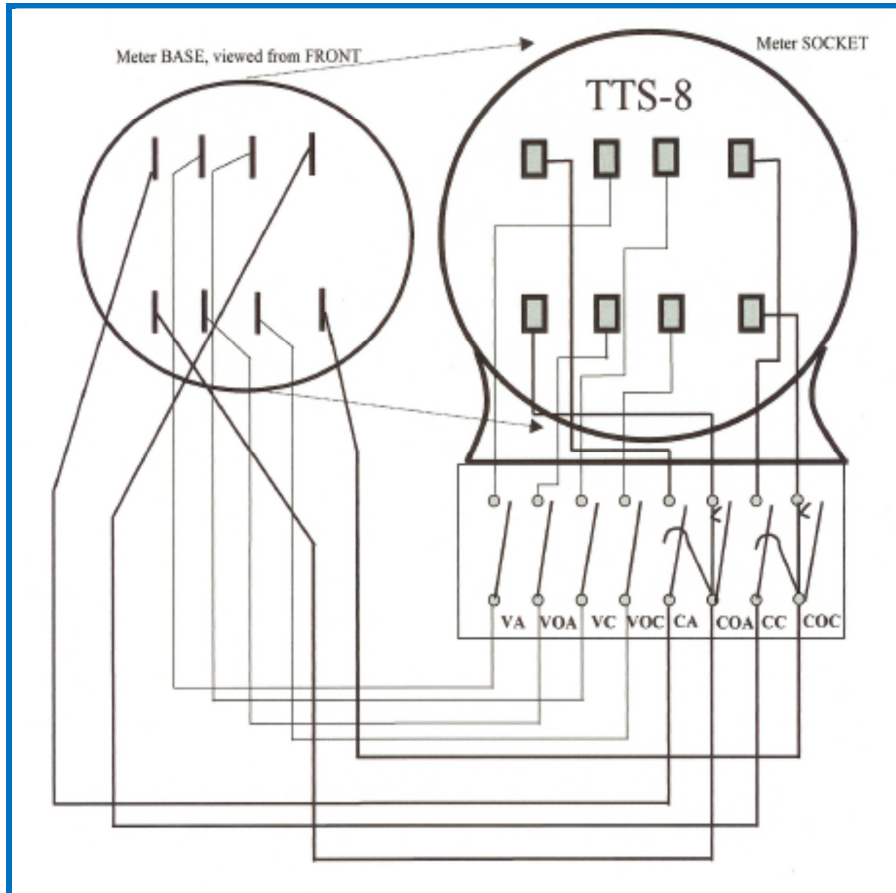

Procedure using the Isolated KYZ Contact Pickup

KYZ is a designation given to a relay used to create pulses for electrical metering applications. It is commonly a Form C relay. The term KYZ refers to the contact designations: K for common, Y for Normally Open, and Z for Normally Closed. When incorporated into an electrical meter, the relay changes state with each rotation (or half rotation) of the meter disc. Each state change is called a "pulse." When connected to the PowerMaster[®], rate of use (kW) as well as total usage (kWh) can be determined from the rate and quantity of pulses.

1. Follow the procedure through steps 1-15 as normal.
2. Connect the Isolated KYZ Contact Pickup to AUX DIGITAL on the PowerMaster[®].
3. Connect the gray lead to K (common) and the orange lead to either Y (open) or Z (closed).
4. After pulses are detected, press F6 to continue.
5. Follow the procedure through steps 17-25 as normal.

Procedure using the Photo Disk Detector

1. Follow the procedure through steps 1-15 as normal.
2. Connect the Photo Disk Detector to AUX DIGITAL on the PowerMaster[®].
3. Install the Photo Disk Detector on the mechanical meter. Line the red photoelectric light to the rotating disk on the meter. Use the blue flathead screwdriver (supplied) to adjust the light sensitivity for pulse detection.
4. After pulses are detected, press F6 to continue.
5. Follow the procedure through steps 17-26 as normal.

Optional Equipment Combinations

When combining optional equipment or using any other custom testing requirements, please contact Powermetrix Technical Support for assistance.

Reference Material

Blondel's Theorem: In a system of "N" connectors, N-1 meter elements that are properly connected, will properly measure the power or energy taken. The connection must be such that all voltage coils will have a common tie to the conductor in which there is no current coil.

Meter Form: A standard watt hour meter designation indicating which type of utility service the meter can measure consumption for. See Table 1 for a detailed break out. The letter designation of “S” or “A” after the number (such as 5S, 5A) indicates the physical connection of the meter. A Type “S” meter is socket based, while a Type “A” is terminal based.

Table 1: Meter Forms and Service Types

# of Wires	# of Phases	Connection Type	Voltage	Meter Form
2	1		120V, 240V	1, 3
3	1		240V	2, 4
3	3	Delta or Wye	120V, 208V, 240V, 480V	5, 12, 35, 45
4	3	Wye	120V, 208V, 240V, 480V	6, 8, 9, 14, 15, 16, 26, 46, 66
4	3	Delta	120V, 208V, 240V, 480V	8, 9, 14, 15, 16, 48

Meter Type: There are two types of meters, transformer rated (designated with a TR) and self contained (designated with a SC). A transformer rated meter monitors current, and sometimes voltage, from the secondary of a current transformer (CT) or a voltage transformer (PT). Transformer rated meters, are not part of the load, and can be removed from service without affecting the load. A self contained meter (SC) is wired into the circuit as part of the load, cannot be removed without affecting the load, and measures voltage and current directly.

Service Type: In the USA there are 5 basic service configurations.

- Single Phase-Two wire
- Single Phase-Three wire
- Three Phase-Three wire
- Three Phase-Four wire wye
- Three Phase-Four wire delta

Basic drawings of these service types are shown below; however these do not represent the full range of voltage potential available in those configurations. For example a Single Phase-Two wire could be 120V line-neutral, 240V Line to Line, 208V Line to line, 277V line to neutral, or 480V line to line. It is important to know and understand the wiring and the upstream transformer at any location

Single Phase-2 Wire

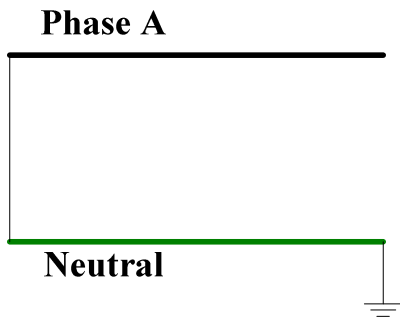

Single Phase-3 Wire

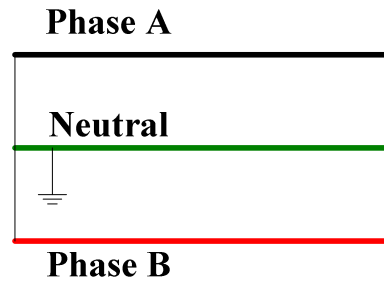

Three Phase-4 Wire

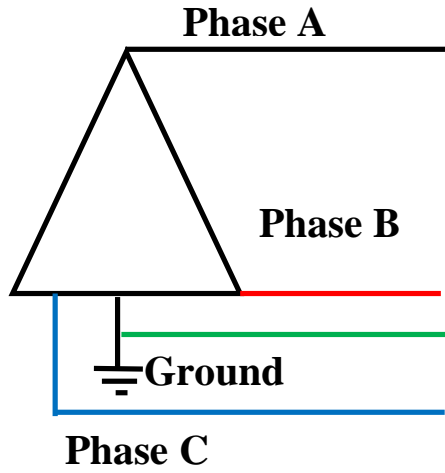

Three Phase-3 Wire Delta

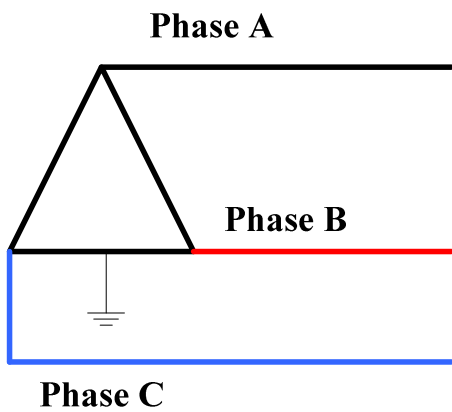

Three Phase-4 Wire Wye

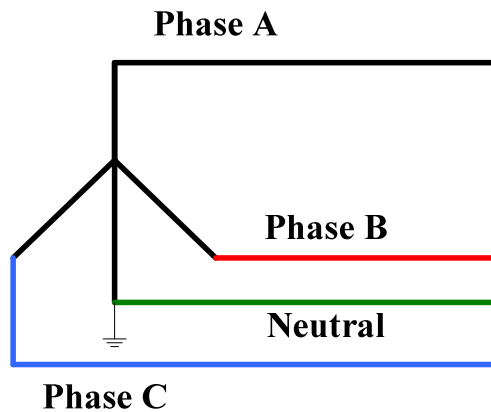

MC Standard Drawings: MC, or Measurement Canada, is responsible for verifying the measurements made in Canada are accurate and verifiable. To this end, several publications and procedures have been produced which specify not only the measurement ability of devices, but what they are allowed to measure. The term “Drawings” is the reference number of various service types, and the types of meters allowed to accurately measure those service types. They develop and enforce the laws as pertaining to measurement, and evaluate and certify measurement devices for use in Canada