

3-Wire Network (1V, 2C) TR

Service Type File:	S004F05
Meter:	5S, 5A
Meter Type:	Transformer Rated
Voltage:	120/208
Current Transformers:	2
Voltage Transformers:	2 (if applicable)
Blondel's Theorem Compliant:	Yes
MC Standard Drawings:	3318, 3319, 3320, 3321, 3322, 3323
PowerMaster Model(s):	5300, 7300
Firmware:	1.0.0.6
App Note Revision:	1.00

Introduction

A variation of the full 3-phase Y service is a 3-wire network in which 2 of the phases (typically A and B phase) are supplied to a customer. Therefore, the vector diagram for this case is exactly the same as the 4-wire Y except the C phase voltage and current are not present.

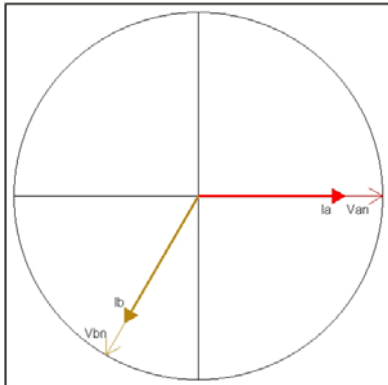



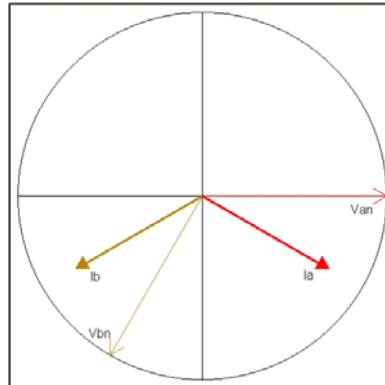



No Lag (1.00 PF)



30° Lag (0.866 PF)

Required Equipment

Item	Qty.		Description	Part Number
1.	1		PowerMaster [®] Model 7300 or 5300	10-130-7300 or 10-130-5300
2.	1		3-Phase Test Switch Current Direct Probes	10-340-0027

3.	1		3-Phase Voltage Cable	10-340-0005
4.	1		3-Phase Probe Adapter Cable	10-340-0014
5.	1		36" Flexible Current Probe (600V, 1000A)	10-100-1036
6.	1		IR Pulse Detector	EP10-100-3327

Optional Equipment

The following equipment may be used as an alternate for the standard accessories:

Item	Qty		Description	Part Number	Alternate For
7.	2		36" Flexible Current Probes (600V, 1000A)	10-100-1036	Item #5
8.	1		Amp LiteWire	SLWIDE-02	Item #5
9.	2		MN353 Clamp-On Probes	10-100-3353	Item #2
10.	2		MN375 Clamp-On Probes	10-100-3375	Item #2
11.	1		Form 5 Meter Base Test Adapter	75-310-0008	N/A
12.	1		Isolated KYZ Contact Pickup	10-120-0005	Item #6
13.	1		Photo Disk Detector	EP10-100-3326	Item #6

Miscellaneous Equipment

Personal Protective Equipment (PPE)

Hot Stick (if using the Amp LiteWire)

Cloth or rag to prevent possible sunlight when using the IR Pulse Detector

Equipment Hookup

The labels correspond to the item numbers from the Required Equipment table above.

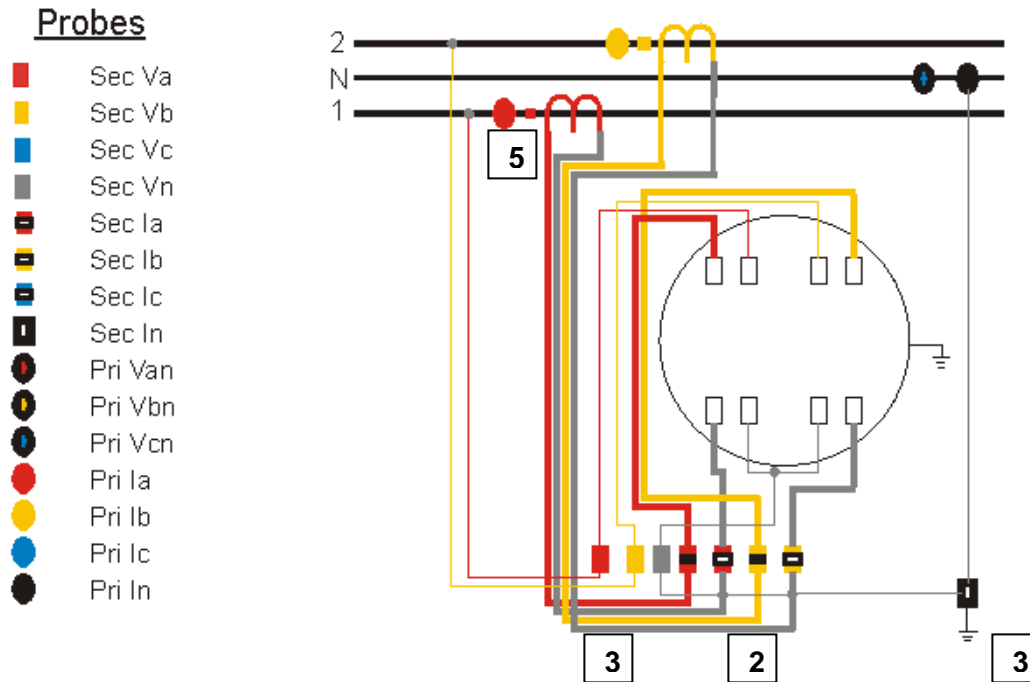

A = Red, B = Yellow, Neutral/Ground = Gray

Procedure

1. Power up the PowerMaster by pressing the ON key.
2. From the PowerMaster, connect the 3-Phase Test Switch Current Direct Probes to CURRENT, and the 3-Phase Voltage Cable to VOLTAGE
3. Connect the 3-Phase Probe Adapter Cable to PROBE SET 1. Connect the 36" Flexible Current Probe (600V, 1000A) to the adapter cable end for A phase (red).
4. Connect the 3-Phase Voltage Cable leads to the potentials of the test switch according to the wiring diagram shown in "Equipment Hookup" (A=red, B=yellow, Neutral=white, Ground=green).
5. Connect the Auxiliary Power leads to a voltage source between 100-530VAC.
6. Insert the 3-Phase Test Switch Current Direct Probes into the current return of the test switch according to the wiring diagram shown in "Equipment Hookup" (A=red, B=yellow). For

polarity, the white side should face up. For safety, shunt the CT current *before* inserting the probes. After insertion, re-engage the CT currents.

7. At the Main Menu, press 1 to “Select Site”

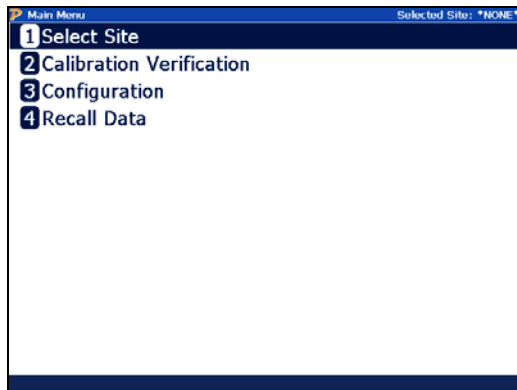

8. In the Site Editor, press F2 to create a new site. If the site is already present in the database, skip to step 12.

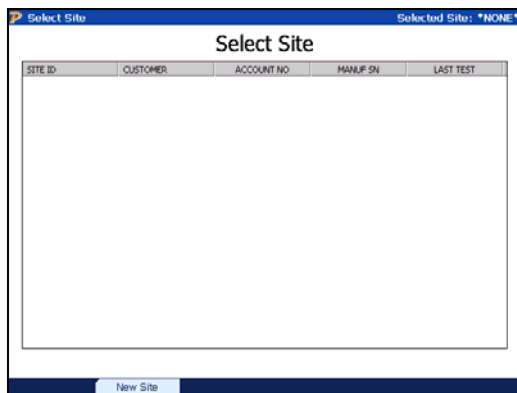

9. In the Site Editor screen, enter the Site ID and select “3-Wire Network (1V, 2C) TR – S004F05” for the service type.

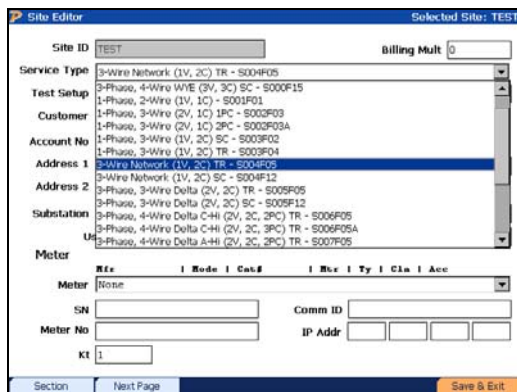

10. Tab to “Test Setup,” and select the appropriate setup for this installation. To create or edit a setup, press F4. For detailed information about the “Test Setup,” refer to Section 7.4.1.1 in the User Manual.

The screenshot shows the 'Site Editor' window with the following fields and values:

- Site ID: TEST
- Billing Mult: 0
- Service Type: 3-Wire Network (1V, 2C) TR - S004F05
- Test Setup: DefSUI1
- Pri Volts: 0
- Customer: (empty)
- Next Test: 2009 Aug 19
- Account No: (empty)
- City: (empty)
- Address 1: (empty)
- State/Prov: (empty)
- Zip: (empty)
- Address 2: (empty)
- Country: (empty)
- Substation: (empty)
- Locator: (empty)
- User 1: (empty)
- User 2: (empty)
- Meter: (empty)
- Meter Mode: (empty)
- Meter SN: (empty)
- Comm ID: (empty)
- Meter No: (empty)
- IP Addr: (empty)
- K1: 1

OPTIONS	
F2	Goes to next page
F4	Goes to Test Editor

11. Enter all other relevant fields in the Site Editor (required fields are in yellow). For detailed information about the Site Editor, refer to Section 7 in the User Manual. Press F6 to continue.

The screenshot shows the 'Site Editor' window with the following fields and values:

- Site ID: TEST
- Billing Mult: 0
- Service Type: 3-Wire Network (1V, 2C) TR - S004F05
- Test Setup: DefSUI1
- Pri Volts: 0
- Customer: HIGH SCHOOL
- Next Test: 2009 Aug 19
- Account No: 123456
- City: (empty)
- Address 1: 123 FAKE ST
- State/Prov: (empty)
- Zip: (empty)
- Address 2: (empty)
- Country: (empty)
- Substation: (empty)
- Locator: (empty)
- User 1: (empty)
- User 2: (empty)
- Meter: (empty)
- Meter Mode: (empty)
- Meter SN: (empty)
- Comm ID: (empty)
- Meter No: (empty)
- IP Addr: (empty)
- K1: (empty)

OPTIONS	
F2	Goes to next page
F6	Saves and continues

12. At the Site Editor, press F6 to select the site to be tested.

The screenshot shows the 'Select Site' dialog box with the following table:

SITE ID	CUSTOMER	ACCOUNT NO	MANUF SN	LAST TEST
TEST	HIGHSCHOOL	1234		11/1/99 1:00 PM

13. Enter the user's name(s) and any comments regarding the installation. Press F6 to continue.

Site Test Information Selected Site: TEST

Technician Name: BOB

Technician Name: FRED

Site Instructions and Information

Your Comments and Notes Regarding This Testing Session

VISUAL INSPECTION OK

Cancel Continue

14. At the Main Menu, press 2 for “Integrated Site Test.”

Main Menu Selected Site: SITE1

- 1 Select Site
- 2 Integrated Site Test
- 3 Meter Testing
- 4 Instrument Transformer Testing
- 5 Data Trending
- 6 Transducer Testing
- 7 Calibration Verification
- 8 Configuration
- 9 Recall Data

15. In “Integrated Site Test,” review and confirm the test setup. Press F6 to continue.

Integrated Site Test Review Selected Site: TEST

Service Type: 3-Wire Network (1V, 2C) TR

Test Setup: Default 1

Meter Tests

Customer Load

Test Mode: Wh Kt: 1,000

Do Demand Test

Test Time: 0 Seconds Test Revs: 3

Phantom Load **NOTE: This unit cannot perform Phantom Load tests**

Phantom Load Setup:

Transformer Testing

CT Test Mode: Burden + Ratio Max Burden: 0.5

PT Test Mode:

Reset Next

16. The PowerMaster[®] will confirm if the probes and lead sets are connected properly for the meter test. Install the IR Pulse Detector onto the meter and connect it to AUX DIGITAL on the PowerMaster[®]. Press F6 to continue.

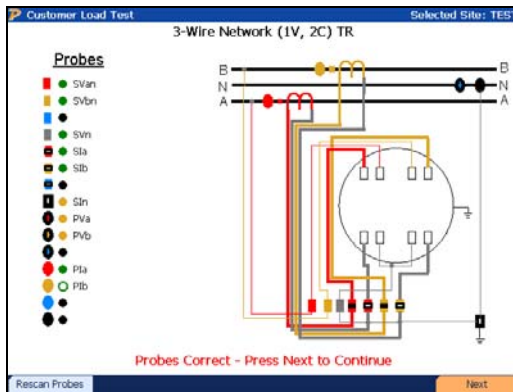

17. The PowerMaster[®] will now check for valid signals for the voltages and currents for the meter test. Next, it will check for meter pulses. After meter pulses are detected, press F6 to continue.

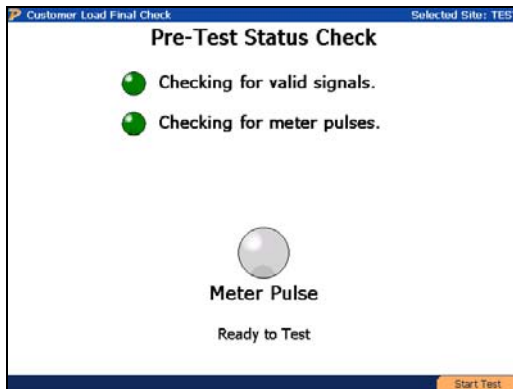

18. After the customer load meter test is complete, review the results. If within tolerance, press F6 to continue.

Test Info		Sys Info	
Time(sec)	20.440	Wh	5.4018
Time Left	0.000	VAh	5.4019
Pulses Exp	3.0010	VARh	-0.0397
Pulses Act	3.0000	V	118.684
Meter PF	1.000	I	2.6768

OPTIONS	
F1	Go back to step 17
F2	View trend plot
F6	Continue

19. The PowerMaster[®] will confirm if the probes and lead sets are connected properly for the CT test. Wrap the 36" Flexible Current Probe (600V, 1000A) around all of the primary conductors for A phase CT. An arrow on the connector denotes polarity (arrow towards load). Press F6 to continue

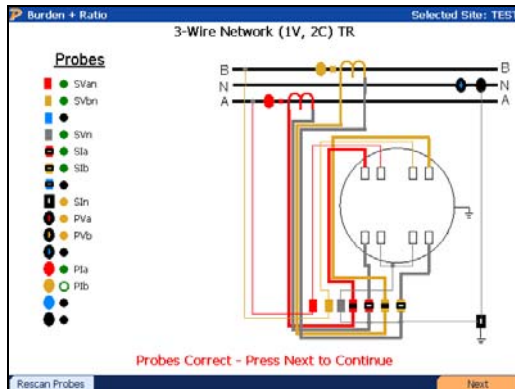

20. Press F6 to test A phase CT.

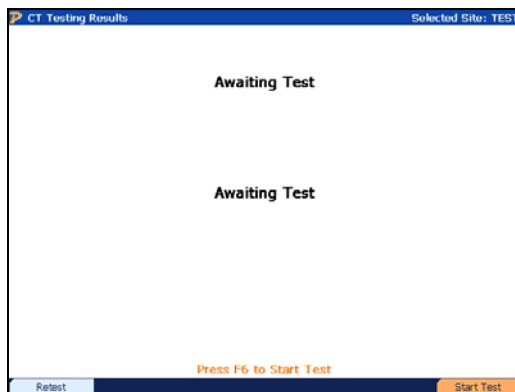

21. View results for A phase CT. Wrap the 36" Flexible Current Probe (600V, 1000A) around all of the primary conductors for B phase CT. Press F6 to continue.

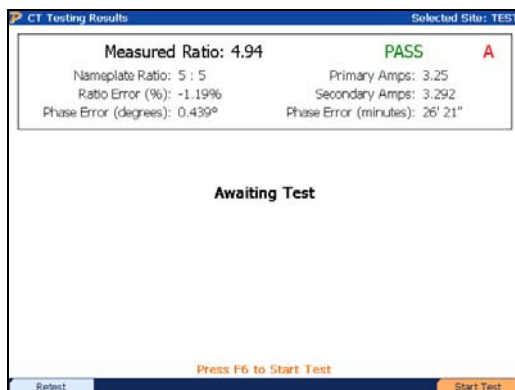

OPTIONS	
F1	Retest A phase CT
F6	Test B phase CT

22. View results for B phase CT. Press F6 to complete the test.

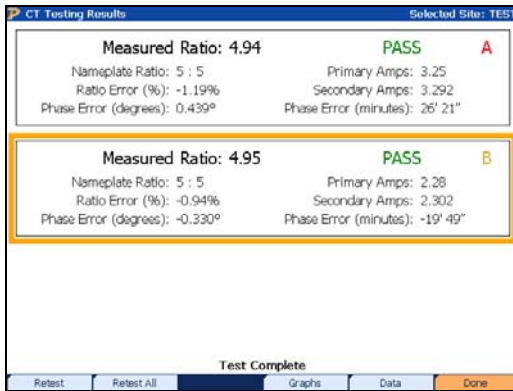

OPTIONS	
F1	Retest B phase CT
F2	Go back to step 20
F4	View graphical data
F5	View numerical data
F6	Complete testing

23. At the Main Menu, select and press Enter for “Recall Data.”

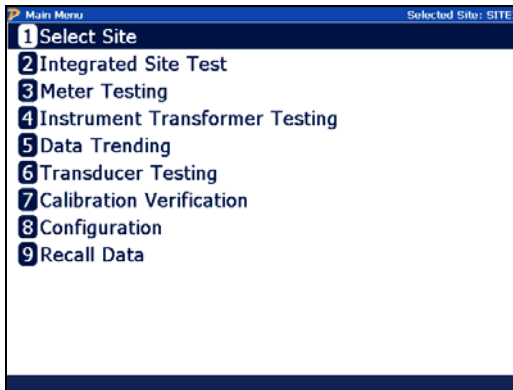

24. Select the site that was tested and review the data before leaving the site. Use up and down arrows to select the site and F6 to expand and view the data. After review is complete, power off the PowerMaster® by pressing the ON key.

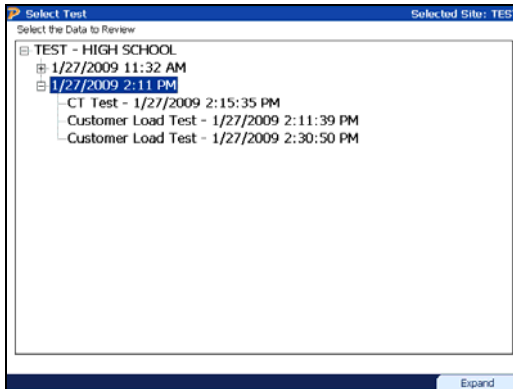

OPTIONS	
▲	Select test
▼	
F6	Open & view data

25. Carefully disconnect all lead sets and probes and properly store them in the accessory case.

Using Optional Equipment

Procedure Using Two 36" Flexible Current Probes (600V, 1000A)

1. Power up the PowerMaster by pressing the ON key.
2. From the PowerMaster, connect the 3-Phase Test Switch Current Direct Probes to CURRENT, and the 3-Phase Voltage Cable to VOLTAGE.
3. Connect the 3-Phase Probe Adapter Cable to PROBE SET 1. Connect the 36" Flexible Current Probes (600V, 1000A) to the adapter cable end for A phase (red) and B phase (yellow).
4. Follow the procedure through steps 4-18 as normal.
5. Wrap the 36" Flexible Current Probes (600V, 1000A) around all of the primary conductors for A and B phase CT. An arrow on the connector denotes polarity (arrow towards load). Press F6 to begin testing.
6. Follow the procedure through steps 22-25 as normal.

Procedure Using the Amp LiteWire

1. Power up the PowerMaster by pressing the ON key.
2. From the PowerMaster, connect the 3-Phase Test Switch Current Direct Probes to CURRENT, and the 3-Phase Voltage Cable to VOLTAGE.
3. Connect the 3-Phase Probe Adapter Cable to PROBE SET 1. Connect the HV Signal Cable to A phase (red) of the 3-Phase Probe Adapter Cable.
4. Connect the HV Signal Cable to the "Analog Output" (BNC) connector on the Amp LiteWire receiver. Connect the male ends of the orange fiber optic cable to the female ends of the transmitter and receiver (for detailed instructions, refer to the Amp LiteWire Operators Manual). Carefully lay the Amp LiteWire aside.
5. Follow the procedure through steps 4-18 as normal
6. Use the Amp LiteWire's chuck adapter to connect to a hot stick. Turn on the Amp LiteWire by first turning on the receiver (press 2x) then the transmitter (press 2x). Once both modules are powered on, the receiver will display 0.
7. Carefully lift the Amp LiteWire into the A phase CT conductors. For polarity, position the face of the transmitter to the load side of the CT.
8. Press F6 to test A phase CT.
9. View results for A phase CT. Carefully lift the Amp LiteWire into the B phase CT conductors. Press F6 to continue.
10. Follow the procedure through steps 22-25 as normal.

Procedure Using the MN353 or MN375 Clamp-On Probes

1. Power up the PowerMaster by pressing the ON key.
2. From the PowerMaster, connect the 3-Phase Probe Adapter Cable to PROBE SET 1, and the 3-Phase Voltage Cable to VOLTAGE.
3. Connect the MN353 or MN375 probes to the ends of the 3-Phase Probe Adapter Cable for PROBE SET 1 (A = red, B = yellow).

4. Connect the 3-Phase Voltage Cable leads to the potentials of the test switch according to the wiring diagram shown in "Equipment Hookup" (A=red, B=yellow, Neutral=white, Ground=green).
5. Clamp the MN353 or MN375 probes around the secondary current path of the meter installation according to the wiring diagram shown in "Equipment Hookup". An arrow on the probe denotes polarity (arrow towards load)
6. Connect the second 3-Phase Probe Adapter Cable to PROBE SET 2. Connect the 36" Flexible Current Probe (600V, 1000A) to the adapter cable end for A phase (red).
7. Follow the procedure through steps 7-25 as normal.

Procedure using the Form 5 Meter Base Adapter

1. Follow the procedure through steps 1-3 as normal.
2. Remove the meter from the meter socket. Place the meter into the Form 5 Meter Base Adapter. Firmly place the Form 5 Meter Base Adapter back into the meter base.
3. Connect the 3-Phase Voltage Cable leads to the potentials of the test switch (VA=red, VC=yellow, VO=white, Ground=green).
4. Insert the 3-Phase Test Switch Current Direct Probes into the current return of the test switch according to the wiring diagram shown in "Fig. 1" (COA=red, COC=yellow). For safety, shunt the CT currents (CA, CC) *before* inserting the probes. After insertion, re-engage the CT currents.
5. Follow the procedure through steps 7-25 as normal.

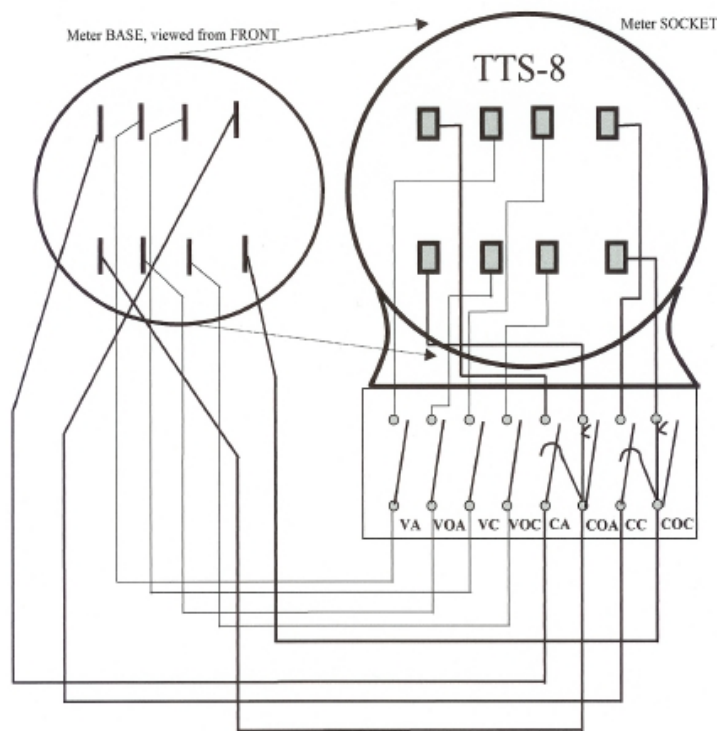

Fig. 1

Procedure using the Isolated KYZ Contact Pickup

KYZ is a designation given to a relay used to create pulses for electrical metering applications. It is commonly a Form C relay. The term KYZ refers to the contact designations: K for common, Y for Normally Open, and Z for Normally Closed. When incorporated into an electrical meter, the relay changes state with each rotation (or half rotation) of the meter disc. Each state change is called a "pulse." When connected to the PowerMaster[®], rate of use (kW) as well as total usage (kWh) can be determined from the rate and quantity of pulses.

1. Follow the procedure through steps 1-15 as normal.
2. Connect the Isolated KYZ Contact Pickup to AUX DIGITAL on the PowerMaster[®].
3. Connect the gray lead to K (common) and the orange lead to either Y (open) or Z (closed).
4. After pulses are detected, press F6 to continue.
5. Follow the procedure through steps 17-25 as normal.

Procedure using the Photo Disk Detector

1. Follow the procedure through steps 1-15 as normal.
2. Connect the Photo Disk Detector to AUX DIGITAL on the PowerMaster[®].
3. Install the Photo Disk Detector on the mechanical meter. Line the red photoelectric light to the rotating disk on the meter. Use the blue flathead screwdriver (supplied) to adjust the light sensitivity for pulse detection.
4. After pulses are detected, press F6 to continue.
5. Follow the procedure through steps 17-25 as normal.

Optional Equipment Combinations

When combining optional equipment or using any other custom testing requirements, please contact Powermetrix Technical Support for assistance.