



PowerMaster[®] 8 Series
Firmware Version 1.1.0.8

Product Manual
Revision 1.3

Copyright Notice:

Copyright © 2016 by TEC. All rights reserved. No part of this document may be reproduced, transmitted, transcribed, stored in a retrieval system, or translated into any language in any form by any means without the express written permission of TEC.

Disclaimer

This documentation is provided for information purposes. TEC makes no warranty of any kind with regard to this material, including, but not limited to, the implied warranties of merchantability and fitness for a particular purpose. TEC shall not be liable for errors, omissions, or inconsistencies which may be contained herein or for incidental or consequential damages in connection with the furnishing, performance, or use of the material. Information in this document is subject to change without notice and does not represent a commitment on the part of TEC.

Table of Contents

Warranty	6
Safety.....	7
Product Manual Release Notes.....	8
1 Introduction	9
2 Product Description.....	10
2.1 Keypad	10
2.1.1 Keypad and USB Keyboard Use Table	14
2.2 Screen	16
2.3 Rear Panel.....	16
2.4 Communication Ports.....	17
3 Graphical User Interface	19
3.1 Controls	19
4 Menu System.....	22
4.1 Menu System.....	22
5 Hot Keys	24
5.1 Waveforms.....	27
5.2 Vector Diagram	29
5.3 Power Meter	31
5.4 Harmonics Analysis	34
5.4.1 Harmonics Details.....	35
5.5 Full Analysis.....	37
5.6 Status Key	38
5.6.1 Software Revisions	40
5.6.2 Probe Scan	41
6 Site Manager.....	43
6.1 How Do I Select a Site	43
6.2 How Do I Create a New Site	45
6.3 How Do I Delete a Site.....	46
6.4 How Do I Edit a Site.....	47
6.4.1 Details on Creating a New Site	47
6.4.1.1 Details on Creating and Editing a Test Setup	51
6.4.2 Creating a New Site: Page 2.....	55
6.4.2.1 Meter Editor: Creating or Editing a Meter.....	58
6.4.3 Creating a New Site: Page 3.....	61

6.4.4	Creating a New Site (Page 4)	62
6.4.5	Creating a New Site (Page 5 & 6)	63
6.4.5.1	PT Editor	64
6.4.5.2	Creating or Editing a PT	66
6.4.6	CT Editor	67
6.4.6.1	Creating or Editing a CT	68
7	Test	69
7.1	Test Menu	70
7.2	Manual Calibration Check	71
7.3	Transducer Testing	74
7.4	Data Trending	76
7.5	Customer Load Setup	77
7.5.1	Customer Load Setup With Demand Test	79
7.5.2	Customer Load Probe Setup	81
7.5.3	Customer Load Final Check	82
7.5.4	Customer Load Test Results	83
7.5.4.1	Customer Load Demand Data	85
7.5.4.2	Customer Load Trending Data	87
8	Remote	88
9	Deselect Site	89
10	Configure	90
10.1	Connect to Meter Site Manager	91
10.2	Save Database Snapshot (Backup)	92
10.3	Install a System Upgrade	94
10.4	Set System Time	96
10.5	User Preferences	97
10.5.1	General Settings	97
10.5.2	Measurement Setup	99
10.5.3	Additional Settings	102
10.5.4	User Defined Fields for the Test Session	105
11	Recall Data	106
12	Specifications	107
13	Accessories	110
13.1	Current Probes	111
14	Precision Pulse Output Description	115

Technical Support

For technical support, please contact the factory at (865) 218-5838 or (877-966-5851 toll free) and ask for “Powermetrix Technical Support” or email Powermetrix at help@powermetrix.com. The support staff will answer questions about the operation and care of your equipment; assist you in troubleshooting system problems; and help you overcome common application difficulties whenever possible. If it becomes necessary for your equipment to be returned to us for any reason, you will be issued an RMA number during the technical support contact.

Feedback

Powermetrix depends on information from our customers to continue the attributes of quality, dependability and simplicity associated with our products. We invite you to contact Technical Support with any comments or suggestions you may have.

Calibration and Certification

Your Powermetrix equipment is calibrated and certified effective the date of shipment. Powermetrix requires the unit to be re-calibrated at the factory, or by a Powermetrix authorized service facility, on an annual basis to ensure accuracy and maintain the precision electronic components. The unit is identified as calibrated by a sticker stating the date of calibration and next due date of calibration. A certificate of calibration is provided to verify compliance for inspectors. A permanent record of your calibration is maintained by Powermetrix. For information on calibration services, contact Powermetrix Technical Support. In addition, current and voltage probes require re-calibration on an annual basis or when dropped, damaged or suspected of improper operation.

Additional services included at no additional charge during annual calibration:

1. Inspect probes, cables, and internal circuit boards
2. Perform preventive maintenance on components
3. Apply ECN's (Engineering Change Notices) to current standards
4. Update application firmware to latest revision
5. Produce a reproducibility report for clamp-on probes
6. Provide a Service Report for all work completed

NOTE:

The annual calibration is required in order to comply with the terms of the PowerMaster® warranty. See “Warranty” in the next section for details.

Warranty

PowerMaster® 8 Series Warranty

TEC/Powermetrix Division warrants the PowerMaster® product to be free of defects in material and workmanship for a period of five (5) years following the purchase date. Note that **there are no user serviceable parts in the unit**. The warranty covers the PowerMaster®, provided it is properly used, stored, and maintained in accordance with provisions in the User Manual. Items not covered under the warranty policy include (but are not limited to) a cracked or broken LCD, water damage, or connecting auxiliary leads to voltages above 240V AC.

Annual calibration at the factory in Knoxville TN is required to maintain the validity and terms of this warranty. Your PowerMaster® unit will alert you when it is time for a re-calibration; please plan to send your unit in at this time. Please contact TEC-Powermetrix Division at (865)218-5838 or help@powermetrix.com to obtain an RMA number and form prior to returning any equipment for service or re-calibration.

If an annual calibration is not maintained for over one (1) year from the purchase date or the last calibration date (within a maximum of five (5) years from purchase date), the warranty is null and void. To re-enter the warranty period, the customer must send the PowerMaster® in at their expense. The warranty is then valid for one (1) year from the calibration date or five (5) years from the purchase date, whichever is longer.

If a repair is required while the PowerMaster® is within five (5) years from the purchase date, but outside one (1) year since the last calibration, the customer has the option of paying for the repair or paying for the annual calibration cost to be re-instated into the warranty period (within a maximum of five (5) years from the purchase date). If the PowerMaster® is outside five (5) years from the purchase date the cost of re-calibration and/or repair service will be at the customer's expense.

Safety

Operation of the PowerMaster® and the supplied accessories and adapters can expose the user to potentially hazardous conditions. Please follow all required safety procedures set forth by appropriate industry standards and the safety organization within the user's company. If no safety organization exists, please follow all applicable OSHA rules and standards for PPE (Personal Protective Equipment) when working in high-voltage and low-voltage environments. This equipment should be used by qualified, trained personnel ONLY.

Safety Tips for Testing:

1. Connect the green safety ground to a true earth ground before testing begins. Remove the green safety ground last after testing is complete.
2. Verify that probes are rated for the voltages or currents being tested.
3. Never attach any probe around a conductor or to a live terminal before connecting it to the adapter cable and the cable to the PowerMaster®.
4. Never disconnect the Current Direct (duckbill) probes from the PowerMaster® while still inserted into the test switch. This will cause the CT to have an open circuit.
5. For LiteWire probes verify the fiber optic cable is clean to prevent surface arcing. For cleaning and maintenance information, refer to the Amp LiteWire or Volt LiteWire manual supplied with the probe.
6. Before inserting Current Direct (duckbill) probes into a test switch, first short the CT secondary (+) by placing the test switch in an open position. This will prevent possible arcing.
7. For clamp-on probes, clean contact surfaces and then snap and release the jaws to ensure metal-to-metal contact of the jaws (dirt and grease may contaminate the surfaces).

Product Manual Release Notes

Product: PowerMaster® 8 Series

Release Date: 2/22/16

Manual Version: 1.3

What's New: 1.1.0.8

1. Fixed CT Burden ratio retest function to avoid crashing during 5S test.
2. Fixed CT Ratio/Burden to avoid crashing during 8S or 9S test.
3. Fixed graphical bug in CT ratio test while using integrated site test on the 3 series.
4. Fixed navigational function keys while in harmonic details hot screen to move correctly.
5. Fixed hot screen to display the correct gain range after running a burden measurement test on 3 series.
6. Fixed PT Ratio test phase error reporting.
7. Fixed label for Qt and Qa in user preferences.
8. Fixed 5S 4W-Wye service type labels for CT testing to be more consistent.
9. Added improvements for better load box/phantom load operation.
10. Added ability for the CT/PT ratio on the hot screen to include PT NPR.
11. Added new battery levels for 7 series.
12. Added new calculations for voltage and current differences on the meter screen.
13. Added enable/disable ratios to recall data.
14. Verified VA always unsigned, regardless of VARS.
15. Adjusted sign convention to make VAR testing more similar to conventional meters.
16. Created and added new handlers to better display potential error codes.
17. Made THD thresholds minimum 5%.
18. Removed unused code and adjusted database for more stability.

What's New: 1.0.2.2

1. Updated Screenshots
2. Added Transducer testing
3. Fixed Typos
4. Updated menu selections and options
5. Updated internal hyperlinks
6. Standardized picture border and width

1 Introduction

The PowerMaster® 8 Series units are true 3-phase analyzing laboratory reference standards with models to satisfy various accuracy class requirements.

User Interface

The user interface is a Windows CE based program that enables the user to perform complex tasks with an easy-to-use dashboard.

Dedicated HOT KEYS on the front panel are used as shortcuts to quickly view waveforms, a vector diagram, the power meter, or harmonic analysis at any time.

With features designed to help meter technicians with their job, this user interface provides a tool supporting metering beginners as well as seasoned technicians and engineers.

Meter Testing

The PowerMaster® performs customer load tests in accordance with ANSI C-12.1-2001 using Method 3 (5.1.5.3). Within seconds the meter accuracy is determined in-place and under real-world conditions, reflecting exactly how the customer is being billed.

Hot Keys

A user accesses several important functions in the PowerMaster® at any time with the push of a single button.

The Waveforms, Vector Diagram, Power Meter and Harmonic Analysis pages all have dedicated buttons on the PowerMaster® front panel. Another button for Full Analysis, displays all four functions simultaneously on one screen for a powerful overview of the entire circuit.

Pressing the Status key displays the condition of the test setup and the internal workings of the PowerMaster®.

These keys can also be accessed using an external USB keyboard via function keys F7-F12.

Database

The PowerMaster® has a built-in SQL database that can hold all information pertaining to the site including (but not limited to) the meter, CT, PT, AMR, account number, address, substation, GPS locator, billing multiplier, and when the site needs to be tested again. The user can easily select a pre-loaded component (meter, CT, PT, etc.) from our large database or create a new component to be associated to each metering site. Using the Meter Site Manager PC software, this information along with data results can easily be synchronized to the master database or formatted into a .csv or .txt file for exporting into the utility's master database. The real power of having a built-in database inside the PowerMaster® is the ability to create a daily "route" of tests for the user that can be setup in the shop (or synched from Meter Site Manager) before going into the field.

2 Product Description

This section provides a brief tour of the PowerMaster® capabilities, describing the various keys and their functions; the input and output ports; and the standard accessories supplied with the PowerMaster®. Optional accessories are discussed later in [Section 11](#).

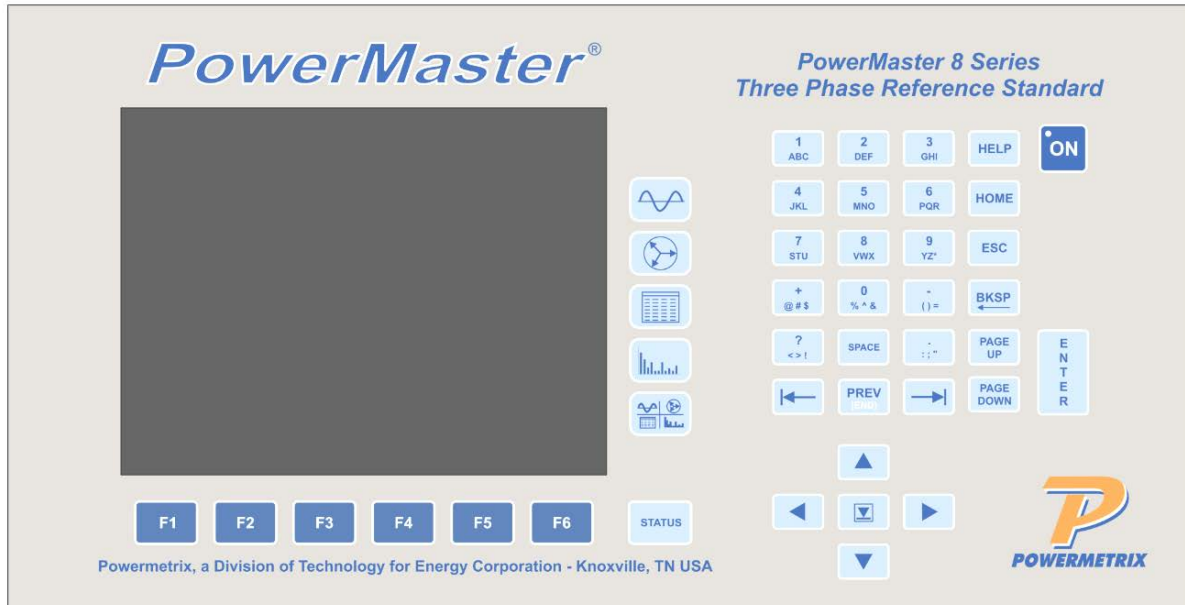

2.1 Keypad

The PowerMaster® has a control panel with 43 keys, described below:



To turn the system on, verify it is plugged into a voltage source (85-264Vac) and the power switch on the back of the unit is turned on. Press and hold the ON key located at the top right of the PowerMaster® keypad until the LED embedded in the key turns green. Pressing the ON button when the system is already running turns the system OFF.



The HOT KEYS located to the right of the display provide quick access to the signal data at any time while using the PowerMaster®. The key functions are: 1) Waveform display, 2) Vector Diagram, 3) Power Meter, 4) Harmonic Analysis, and 5) Full Analysis, respectively. For more information on the hot key functions, see [Section 5](#).

STATUS

The STATUS key can be pressed at any time and displays the internal state of the PowerMaster®, the user's setup criteria, and other helpful information about the PowerMaster® unit.

F1

F2

F3

F4

F5

F6

Six function keys (F1 - F6) are located below the PowerMaster® display with rectangular label boxes on the display directly above each function key.

The purpose of each key may be different on each screen and the labels change to reflect what the key will do if pressed. When a label is blank, the corresponding key does nothing on that screen.



The TAB key moves the cursor from one field to the next field on a form.



The BACK TAB key moves the cursor from one field to the previous field on a form.



When the cursor is located in a drop-down box field, pressing the DROP-DOWN key displays all the available selections. Use the up and down arrow keys to highlight a particular item then press the DROP DOWN key a second time to select the item and close the drop-down list.

Pressing this key in a checkbox will toggle (check/uncheck) the check mark.

PREV
(END)

The PREVIOUS key is used to allow the user to go back to the previous screen. Continually pressing this key will always (eventually) take the user back to the Main Menu.



The DIRECTIONAL keys are used to move the cursor up or down in a menu selection, particularly to select an item from a drop-down box list. The selections in a drop-down box list can be viewed one at a time using these keys without pressing the DROP-DOWN key.

HOME

The HOME key has no current function at this time. (Function currently in development; firmware update coming soon).

HELP

The HELP key currently does nothing. (Function currently in development; firmware update coming soon).



The ESCAPE key is an “undo” key when entering text. When the cursor is in a field for data entry, pressing the ESCAPE key at any time will delete all the data that has been entered in that field. Pressing ESC again “re-does” the previous text before edits were made.



The BACKSPACE key deletes one character at a time to the left of the cursor, or deletes all the highlighted text in the field.



If a form is too large to fit entirely on the screen at one time, the PAGE UP and PAGE DOWN keys scroll the display screen up or down one whole page.



Pressing the ENTER key activates the current item selection or accepts the data on the current form.



The 14 multi-character keys on the front panel provide the ability to enter letters, numbers, and symbols into the PowerMaster®.

Each key operates the same way: press the key quickly once for the first character, twice for the second, three times for the third and four times for the fourth. Additional quick presses will cycle through the characters until you stop pressing quickly.

If the next character needed is on a different key, simply move on to press the next key.

However, if the next character is on the same key, say “F” followed by “E”, then pause for 1 second to let the first character appear before beginning to press the key again for the next character.

The “period” key (to the right of the space key) is also used to enter the decimal point in real numbers like the Kt value of a meter (e.g., 1.8).

















SPACE







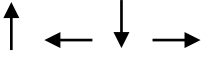

The SPACE key is primarily used to separate words in text fields.

Pressing this key in a checkbox will toggle (check/uncheck) the check mark, while pressing it in a list will toggle the selection highlight of the item at the cursor.

2.1.1 Keypad and USB Keyboard Use Table

The PowerMaster® supports operation by connecting an external USB keyboard and/or mouse to the USB ports on the back panel. The following table identifies which keys on the keyboard correspond to keys on the PowerMaster® keypad.

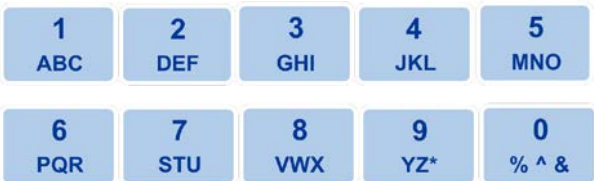
Label	PowerMaster® Key	USB Keyboard Key
On		N/A
Waveforms hot key		F7
Vector Diagram hot key		F8
Power Meter hot key		F9
Harmonic Analysis hot key		F10
Full Analysis hot key		F11
Status hot key		F12
Function keys		F1 – F6
Tab key		Tab
Back Tab key		Shift + Tab
Drop-Down key		Num Lock, 5
Previous key		End
Directional keys		
Home key		Home

Help key		N/A
Escape key		Esc
Backspace key		Backspace
Page Up, Page Down	 	Page Up, Page Down
Enter key		Enter
Space key		Space bar
Character keys (Numbers)		1 – 0
Character keys (Letters)		A – Z
Character keys (Symbols)		* % ^ & ? < > ! + @ # \$ - () = - () = : ; "

NOTE: The PowerMaster® keyboard does not provide equivalents for tilde, *accent grave*, underscore, apostrophe (“foot” mark or *accent acute*), forward or backward slash, a vertical bar (pipe), brackets or braces. There are also no shift, alt, or control keys.

2.2 Screen

The full graphics Liquid Crystal Display (LCD) screen is how the PowerMaster® communicates with the user. In computer technology, the screen is the “graphical user interface.” The screen displays messages, menus, selection lists and graphic illustrations.

The full-color VGA (video graphics array) display measures 8.4” diagonally with a resolution of 640 x 480 pixels. It is a *transflective* display, which means that the screen is readable in any lighting situation from full darkness to full sunlight. A thin piece of clear polycarbonate material is mounted on top of the display to protect the screen.

2.3 Rear Panel



CURRENT

These 6mm Multi-Contact female socket connectors provide direct access to the AC current inputs of the measuring standard and are rated at 50 amps.

The connector pairs are color-coded by phase: red for A, yellow for B and blue for C. The top connector of each pair (all black) is for the current source and the bottom connector (white ring) is for the return.

VOLTAGE

These safety banana plug female socket connectors provide direct access to the voltage inputs of the measuring standard. The four voltage measurement inputs are each rated at 1000 VDC peak (600 VAC RMS).

Measurements can be made phase-to-phase, phase-to-neutral, or phase-to-ground.

PROBE SET #1 & PROBE SET #2

These connectors provide access to six channels (grouped into two sets of three) of low voltage AC measurement. All PowerMetrix current and voltage probes are compatible and can be used in any combination. Each input connects to a 3-phase probe adapter cable that is terminated with three color-coded connectors; red for phase A, yellow for phase B and blue for phase C. When probes are connected to the end of the probe adapter cable the PowerMaster® recognizes the type of probe and its calibration details.

To use clamp-on current probes for secondary current measurements — normally model MN375 probes —connect the adapter cable to PROBE SET #1. Probes for any other purpose may be connected to either probe set input. If you wish to use three probes for simultaneously measuring the primary currents connect all three to the same probe set.

When testing systems with both primary and secondary currents, the user would normally use the CURRENT direct inputs to measure the secondary currents and probes connected to Probe Set 1 to measure the primary currents. In cases where a test switch is not available, a set of MN375 probes would be connected to PROBE SET 1 for measuring secondary current and another set of probes (SR752, JM875, FLEX current probes, or Amp LiteWire) would be connected to PROBE SET 2 to measure primary current. By using two separate probe sets, the user can view both the secondary and primary currents without moving or changing connections.

For self contained meters, connect the current probes to PROBE SET #1.

Specifications for available probes can be found in [Section 11.1](#).

AUX DIGITAL

This external port is normally used with meter testing pickups which are all terminated with the mating 9-pin connector. It can also be used as a calibration pulse output.

AUX COMM

This external port currently has no function.

Standard Out (STD Out)

These are the pulse outputs from the measurement standard, each of which may be assigned to one of the following choices:

The signal outputs are open-drain CMOS compatible with a 1K pull-up resistor to 5 volts internally. See appendix on set points.

Standard In (STD In)

This input is designed for high frequency pulse counting from other standards.

The signal inputs are 5-volt CMOS logic compatible.

Meter Pulse In

This input accepts the output pulse from the test port of a meter and usually originates from an optical pickup.

Power Entry Module

The power entry module accepts a standard IEC power cable and incorporates the power ON/OFF switch and a fuse holder. Dual fuses can be used where appropriate. Accepts 85-264Vac at 47-63Hz.

Fan

The fan circulates cooling air through the internal system during operation and has a foam filter to help remove dust from the external air.

The filter must be cleaned periodically so proper airflow is maintained.

2.4 Communication Ports

USB PERIPHERALS

These two USB ports are used for external USB devices. Examples of these devices are a keyboard, mouse, barcode reader, memory storage device, etc.

USB TO HOST

This port is for a Type B USB cable (standard accessory) for connectivity to a host computer. This port is used to communicate with the PowerMaster® PC software *Meter Site Manager*.

RS-232

This port currently serves no function.

ETHERNET

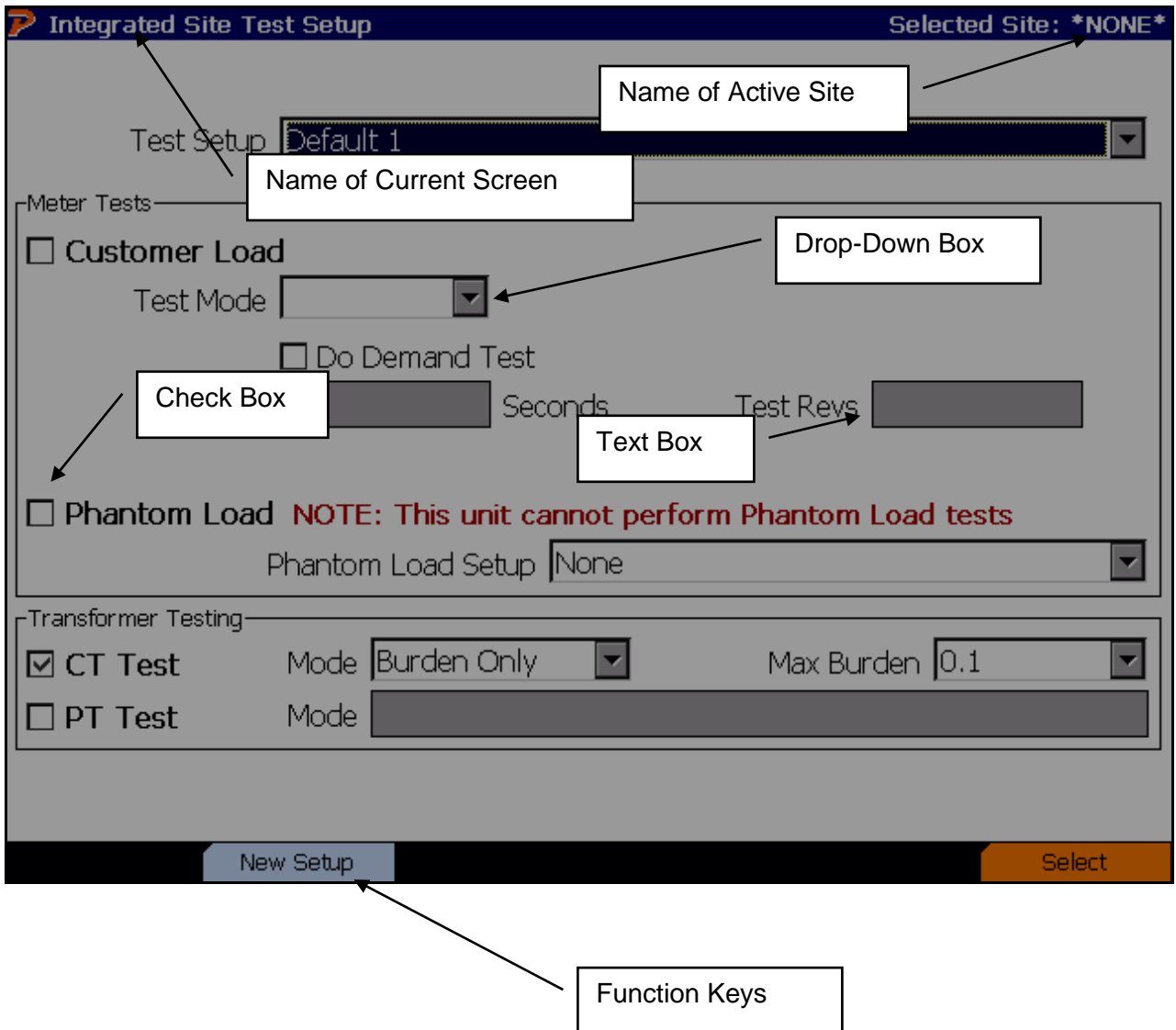

This port provides a high-speed connection to the measuring standard for remote control and data access.

3 Graphical User Interface



3.1 Controls

The PowerMaster® human interface uses familiar Microsoft Windows-style controls. The default behavior of many of the controls has been enhanced to eliminate the need for a pointing device such as a mouse.

Movement between controls on the screen is accomplished using the tab keys  or  to place the cursor in a particular control. The order of fields is pre-defined and follows a specific sequence.

Required Fields Meter kWh 

These tagged fields (with a yellow background) require the user to provide input before continuing to the next screen. If the user tries to continue with no entry, a pop-up window states,

“These fields are required: x,x,x” “Enter to continue” and the cursor returns to the first required field.









Text Boxes Meter kWh

When the cursor enters the control, any data in the text box is highlighted. Typing at this point will replace the information currently in the text box.

If the text box is colored gray, the field is read-only and cannot be edited. This is typically data from the master database which is presented for reference purposes.



Drop-down boxes

When the user tabs into a drop-down list box, they can change the current selection in one of two ways:

1. Press  or  to move to the previous or next selection in the list, press  to accept and continue.
2. Press  to display the entire selection list, then press  or  to make a selection, press  again or ENTER to accept the selection. **NOTE:** focus remains on the drop-down box. The user must press  to go to the next field.





In drop-down boxes, the user can also enter text as long as an item is not presently selected.

Check Boxes Va

When the user tabs into a check box, the label highlights in orange. The user can then press  or  key to change the state of the check box.

Tes	Phase	Label	Voltage
1			
2			
3			

Grid Control

A user enters the grid by using the tab keys. Within the grid, the user can use the directional keys , , ,  to navigate among the cells (denoted by an orange cursor).

To edit a highlighted cell the user presses the  key to edit the cell as a text box or drop-down a combo box to make a selection.

When finished editing the cell, the user presses the  key to accept the change.

ESCAPE key

The  key is an “undo” key when entering text. It returns the contents of the control to its previous value.

Every text box and combo box remembers two things: The **old text** (the content when the user first entered the field or after the last Undo/Redo) and the **new text** (the user's most recent changes).

Pressing  after changing the content of a text box or drop-down box causes it to *undo* (put back the **old text**).

Pressing  again causes it to *redo* (swap back to the **new text**).



As long as the user keeps pressing  the field will continue to switch back and forth between **old text** and **new text**.

4 Menu System

At power up, the PowerMaster® displays a “splash” screen briefly. If the user has a USB mouse connected to one of the USB Peripherals, the screen can be paused for 10 more seconds. After the 10 seconds are complete, the analyzer will boot up to the main menu as normal.

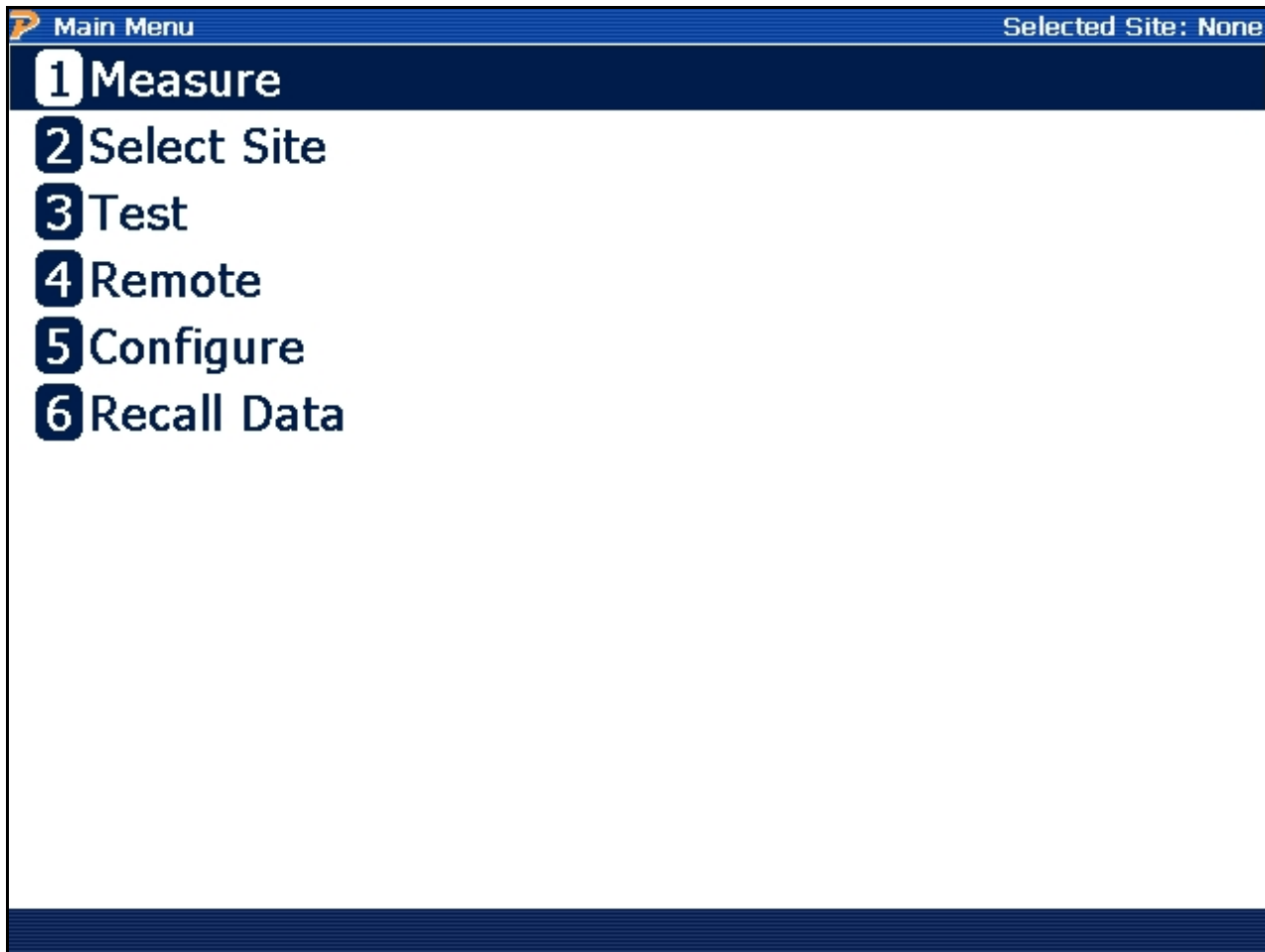
4.1 Menu System



All menus in the system operate in the same manner. A menu entry is selected by using the  and  keys to move up and down between items.

Pressing the  key then causes the selected item to be executed.

Pressing the numeric key corresponding to the menu item executes it immediately.







The main menu options (discussed later) are:

- 1) **Measure**
- 2) **Select Site**
- 3) **Test**

- 4) **Remote**
- 5) **Configure**
- 6) **Recall Data** (view previously saved data).

5 Hot Keys

Hot keys are used as “shortcuts” to access specific screens in the PowerMaster®. The PowerMaster® supports (6) hot keys:

Waveform	
Vector Diagram	
Power Meter	
Harmonics	
Full Analysis	
Status	

A hot key is accessible at ANY time in the application and when a hot key is pressed the selected screen appears with full capabilities enabled.

When a hot key screen is displayed the PowerMaster® remembers the form that was being used at the time the hot key was pressed. When the same hot key is pressed a second time the remembered form is re-displayed.

Pressing  is another way to return from a hot screen to the previous activity; it is equivalent to pressing the same hot key twice in a row.

Common Function Keys:

F3	Instantaneous, Interval, Test Period
-----------	--------------------------------------

This function key is found on the Vector Diagram, Power Meter and Harmonic Analysis screens and allows the user to view the active measurements in three different time bases:

Instantaneous: This is the default measurement interval. Measurements are based on a 4 cycle long measurement and the PowerMaster® screen updates once per second.

Interval: This screen updates every second. During a meter test the interval is set to the pulse interval from the meter.

Test Period: In this mode the PowerMaster® collects measurements until the user tells it to stop (F6). Energy quantities are accumulated (summed) and all other signals are averaged.

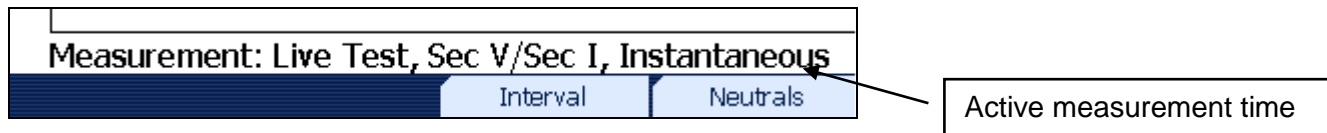

F4	Sec V, Sec I; Sec V, Pri I; Pri V, Pri I; Neutrals
-----------	--

This function key is found on the Waveforms, Vector Diagram, Power Meter and Harmonic Analysis screens and allows the user to view measurements from different probe sets that are attached to the PowerMaster®. This process may include viewing a single probe for a certain application or it may be to change the “power pairs” altogether.

Sec V, Sec I: This is the default selection. This setting corresponds to the secondary voltage probes and the secondary current probes (test switch probes, clamp-on probes, etc.).

For metering this is the “power pair” used for calculating power and registration.

Sec V, Pri I: This setting corresponds to the secondary voltage probes and the primary current probes (flexible current probes, Amp Litewire, etc.). To view the relationship between the secondary voltage and the primary current, this is the correct selection.

This setting will change the “power pair” and power (W, VA, VAR) is calculated according to the inputs selected.

If no primary probes are detected, this setting is not available.

Sec V, Pri V: This setting corresponds to the secondary voltage probes, and the primary voltage probes (Volt LiteWires). To view the relationship between the secondary voltage and the primary voltage, this is the correct selection.

This setting will change the “power pair” and power (W, VA, VAR) is calculated according to the inputs selected.

If no primary probes are detected, this setting is not available.

Neutrals: This setting corresponds to a single secondary voltage probe and a secondary clamp-on current probe (MN353 or MN375). This allows the user to view the secondary neutral phase for the voltage and current.

If no single clamp-on probe is detected, this setting is not available.

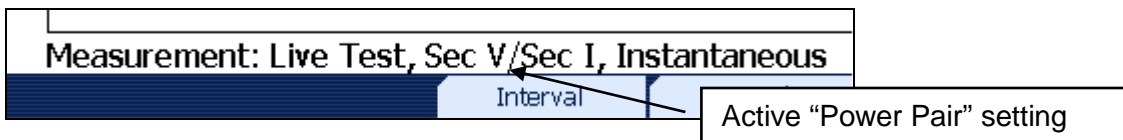

F5	Enable Ratios
----	---------------

This function key is found on the Vector Diagram and the Power Meter and allows the user to view measurements with the CT and PT ratios enabled. When a CT and PT are selected in the Site Editor, the ratios are used to calculate all power measurements without the requirement of primary current and voltage probes.

F2	Toggles between Connection View and Meter View
----	--

This function key is found on the Waveforms, Vector Diagram, Power Meter, Harmonic Analysis and Full Analysis screens. It allows the user to view the different signals according to the meter installation.

Meter View is the default display and shows the signals that are internal to the meter.

Connection View displays the signals as they are connected at the actual terminals, such as a test switch. *While in Connection View power is not calculated.*

Below is an example of a 3-Phase, 4-Wire WYE (2V, 3C) Z-coil TR – S009F06 using both Meter View (default) and Connection View:

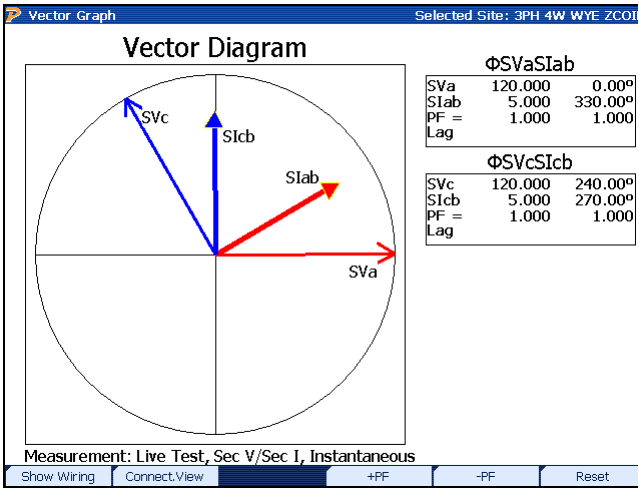

Meter View

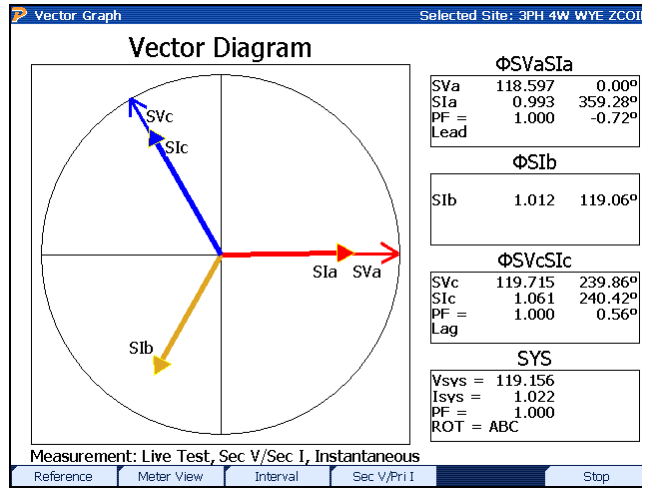



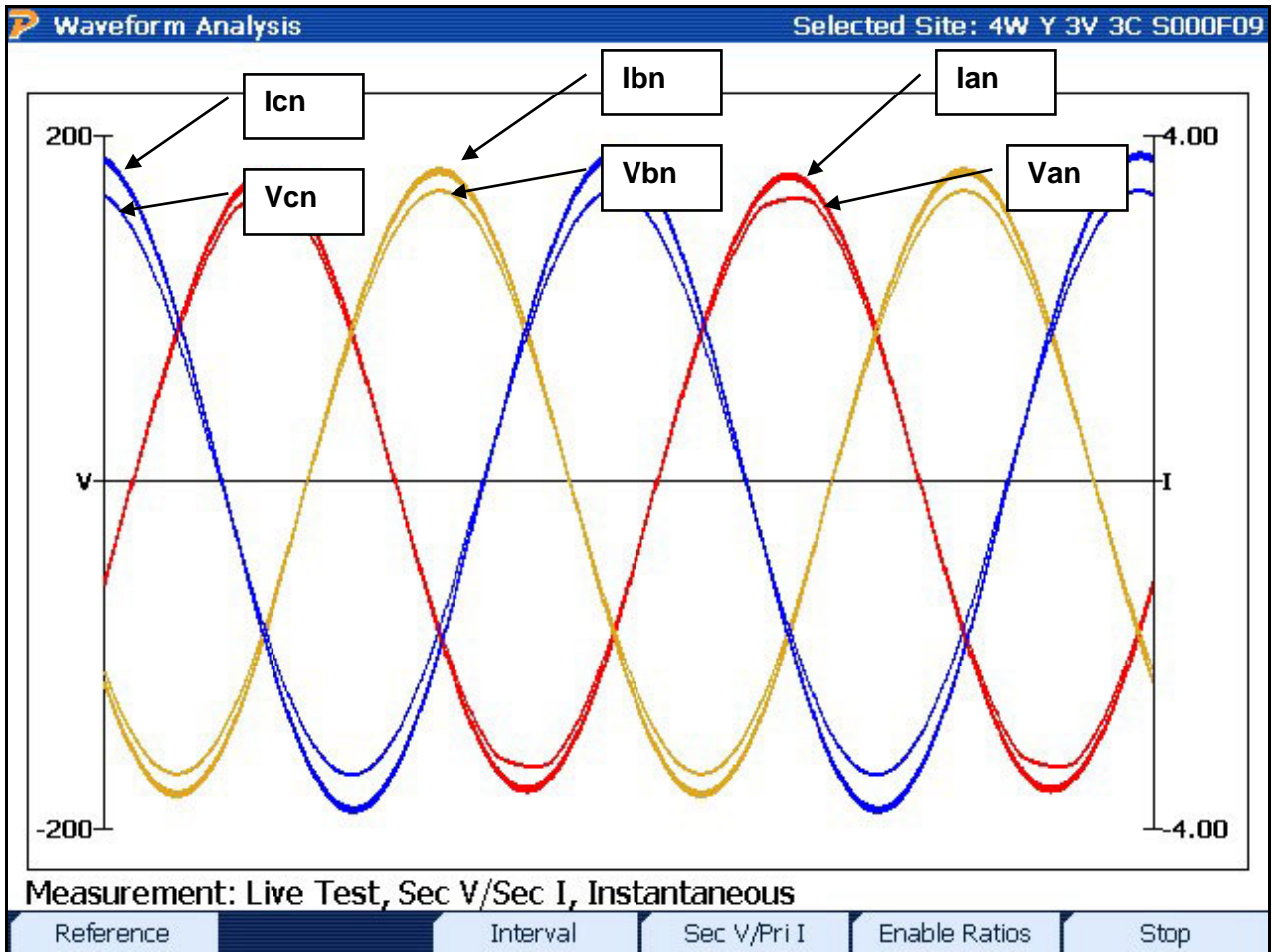

Connection View

5.1 Waveforms



Functionality:

	Toggles between waveform pairs and full waveform displays
	Toggles between Connection View and Meter View (see Section 5 for details)
	Toggles between Sec V/Sec I, Sec V/Pri I, Pri V/Pri I and Neutrals (if correct probes are detected; see Section 2.3 for details)
	Stops all active measurements and “freezes” the display
	Closes the Waveforms screen and returns to the previous activity

Description:

The oscilloscope-like Waveforms display shows the amplitude and phase relationships in time between the measured voltage and current signals.

All phases are color-coded (A = red, B = yellow, C =blue) and the line weight for each phase is used to differentiate between the voltages and currents. The voltage lines are displayed with a thinner line than the currents (see graph labels above).

The x-axis (horizontal) is time (in a 4-cycle measurement) and the y-axis (vertical) is amplitude (i.e., volts and amps). The primary y-axis (left) is for the voltage amplitude and the secondary y-axis (right) is for the current amplitude.

The waveform display uses an auto-scaling function which shows both currents and voltages efficiently even when one amplitude is much greater than the other.

When harmonic distortion is present the waveform lines will appear uneven to display non-linear load situations.

Leading or lagging power factor may be determined here.

When the current waveform peaks *after* the voltage waveform the power factor is considered to be “lagging” and is termed an *inductive* load; this is normal in most metering installations.

When the current waveform peaks *before* the voltage waveform, the power factor is considered to be “leading” and is termed a *capacitive* load. A leading power factor is not as common in metering, but can be seen when capacitor banks are used in service installations and the load is running at less than the capacitor bank was sized for.

Phase rotation can easily be seen in this graph as well; whichever phase voltage peaks first in time determines the phase rotation.

If the A phase voltage displays its peak first in the waveform, the rotation is considered to be ABC.

If the C phase voltage displays its peak first in the waveform, the rotation is considered to be CBA.

In the graph above, the rotation is ABC since A phase voltage displays its full peak first.

5.2 Vector Diagram

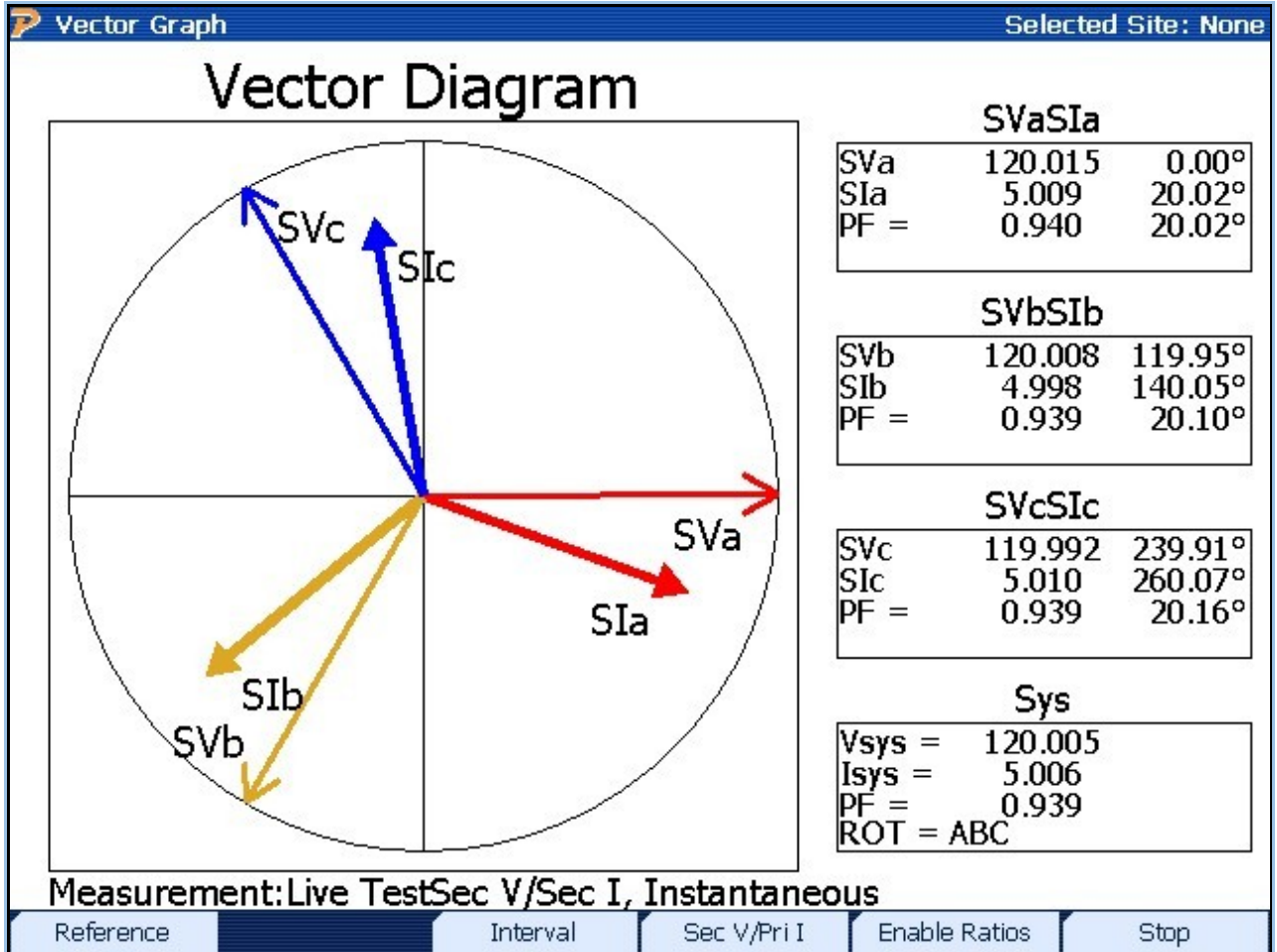

Functionality:

F1	Switches the display to the reference vector diagram
F3	Toggles between Instantaneous, Interval, and Test Period (see Section 5 for details)
F4	Toggles between Sec V/Sec I, Sec V/Pri I, Pri V/Pri I and Neutrals (if correct probes are detected)
F5	Displays calculated values with CT and PT ratios enabled (defined in the Site Editor, Section 6.4.2)
F6	Stops all active measurements and “freezes” the display enables F1 to manually save data
	Closes the Vector Diagram screen and returns to the previous activity

Description:

The Vector Diagram is arguably the best tool for site analysis.

On one screen the PowerMaster® displays the phase relationship between the currents and voltages — representing the “power pair” where all power is calculated.

The length of the displayed lines is proportional to the current and voltage readings; as the amplitudes increase, the lines get longer.

The phase angle in degrees is displayed to show the relationship in time based on how the service transformers are wired. In the USA, Van or Vab is always displayed at the $\cos(0^\circ)$ line (i.e., 3 o'clock position). In Canada, service types typically plot Ean at 330° and Eab at 270° .

The user is allowed to change the “power pair” when primary probes are detected (voltage and/or current). For secondary currents, the vector displays “SVan” to signify the secondary current for A voltage in reference to Neutral. Similarly, the secondary currents are labeled “Sla” to signify the secondary current for A phase.

If primary probes are detected, the user can press F4 to switch the “power pair” to view the relationship between the secondary voltages (SVan) and the primary currents (PIa). The user can press the F4 key again to view the relationship between the primary voltages (PVan) and the primary currents (PIa) as well. Power will be calculated accordingly.

Leading or lagging power factor is also displayed here.

As the current vector shifts to the right of the voltage vector (clockwise), the power factor is considered to be *lagging* and is termed an *inductive* load. This is normal in most metering installations.





As the current vector shifts to the left of the voltage vector (counter-clockwise), the power factor is considered to be *leading* and is termed a *capacitive* load. A leading power factor is not as common in metering, but is normally seen when capacitor banks are used in service installations when no load is present.

Rotation (“ROT”) is displayed in the System (SYS) box to signify the rotation of the service transformers (ABC or CBA). The “SYS” values are the averages of the voltage, current, and power factor for all active phases.

5.3 Power Meter

Power Meter		Selected Site: None		
SYSTEM OVERALL SUMMARY				
	SVa(SIa)	SVb(SIb)	SVc(SIc)	System
V(FDRMS)	120.0161	120.0082	119.9927	120.0057
V(Fund)	120.0161	120.0081	119.9926	120.0056
I(FDRMS)	5.006692	4.995729	5.007843	5.003421
A(Fund)	5.006672	4.995727	5.007835	5.003411
V θ	0.0000°	119.9469°	239.8970°	
I θ	20.0352°	140.0645°	260.0783°	
DPF θ	20.03522°	20.11759°	20.18131°	
PF(PF1a)	0.939482	0.938989	0.938606	0.939026
WP1	564.517	562.950	564.012	1691.478
VAS1	600.881	599.528	600.903	1801.311
VARQ1	205.8607	206.2064	207.3056	619.3728
THD V	0.078115%	0.160521%	0.113520%	0.117385%
THD A	0.286667%	0.078192%	0.174419%	0.179759%
FREQ	60.00000	59.99997	60.00001	59.99999
Measurement: Live Test Sec V/Sec I, Instantaneous				
		Interval	Sec V/Pri I	Enable Ratios
				Stop

Functionality:

	Toggles between Instantaneous, Interval, and Test Period (see Section 5 for details)
	Toggles between Sec V/Sec I, Sec V/Pri I, Pri V/Pri I and Neutrals (if correct probes are detected; see Section 5 for details)
	Displays calculated values with CT and PT ratios enabled (defined in the Site Editor, Section 6.4.3)
	Stops all active measurements and “freezes” the display enables F1 to manually save data
	Closes the Power Meter screen and returns to the previous activity

Value Descriptions:

V(xx)	Voltage measurement per phase (actual calculation is defined in Measurement Calculations)
V(Fund)	Fundamental voltage measurements per phase (inside 50Hz or 60Hz bin via FFT)
I(xx)	Current measurement per phase (actual calculation is defined in Measurement Calculations)
A(Fund)	Fundamental current measurement per phase (inside 50Hz or 60Hz bin via FFT)
V θ	Absolute phase angle measurement for voltage (reference phase is service type dependent)
I θ	Absolute phase angle measurement for current (reference phase is service type dependent)
DPF θ	Displacement Power Factor (difference between V θ and I θ)
PF(xx)	Power Factor for each phase; average or RSS in System (actual calculation is defined in Measurement Calculations)
W(xx)	Watts per phase; sum of all phases in System (actual calculation is defined in Measurement Calculations)
VA(xx)	Volt-Amperes per phase; sum of all phases in System (actual calculation is defined in Measurement Calculations)
VAR(xx)	Volt-Amperes Reactive per phase; sum of all phases in System (actual calculation is defined in Measurement Calculations)
THD V	Total Harmonic Distortion for voltage; average or RSS in System (fundamental divided by sum of harmonics via FFT, displayed in %)
THD I	Total Harmonic Distortion for current; average or RSS in System (fundamental divided by sum of harmonics via FFT, displayed in %)
FREQ	Measured fundamental analysis frequency; average in System (should be 50Hz or 60Hz as set in Configuration)

Column Labels

The labels for each column are determined by the active “power pairs” selected by the F4 key. For example, the first column has a label of “**ΦSVanSla**”. This corresponds to the secondary voltage (referenced to neutral) and the secondary current for A phase.

Text at the bottom of the screen also identifies which “power pair” is active (e.g., “Sec V/Sec I”). Further details of the “power pairs” can be found in [Section 5](#).

Pulse Output

One of the functions of the Power Meter is to display power information during a W-hr/Var-hr standard accuracy check against the PowerMaster®. The pulse output on the PowerMaster® is always active so the power calculation option selected in the User Preferences (see [Section 9.7.3](#)) is noted in bold-faced text on the bottom of this screen.

The measured power (default “Instantaneous”) or actual consumption (press F3 to change to “Test Period”) is displayed while the screen is active.

Pressing F6 stops active measurements and enables the option of saving the data (F1) or restarting the measurement (F6).

For more detailed information on the pulse output, see Appendix 1.

5.4 Harmonics Analysis

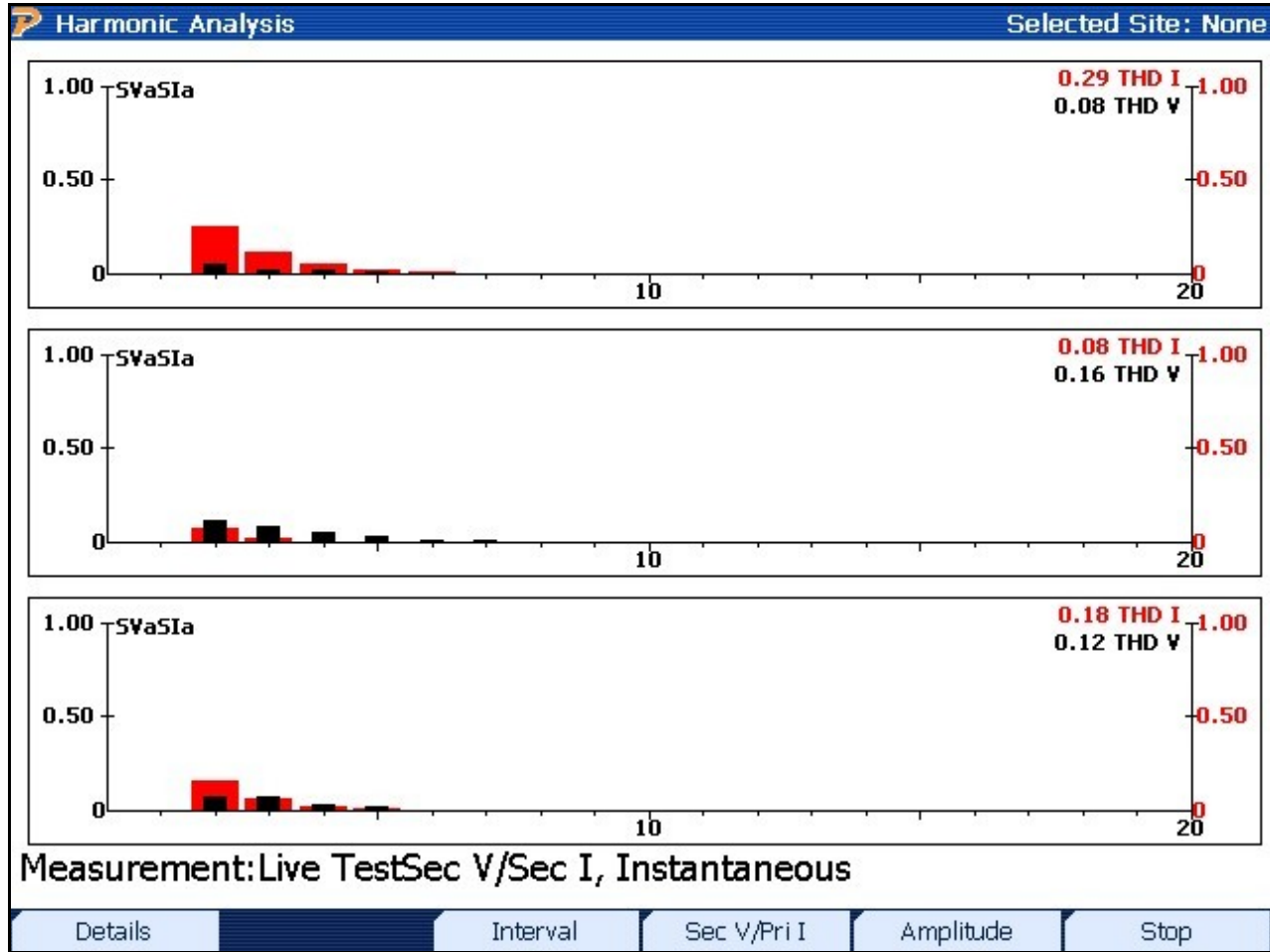

Functionality:

F1	Displays the data per phase in tabular form for each harmonic (up to 100 orders)
F3	Toggles between Instantaneous, Interval, and Test Period (see Section 5 for details)
F4	Toggles between Sec V/Sec I, Sec V/Pri I, Pri V/Pri I and Neutrals (if correct probes are detected)
F5	Toggles the display units between % (of the fundamental) and amplitude (volts and amps)
F6	Stops all active measurements and “freezes” the display enables F1 to manually save data
	Closes the Harmonics Analysis screen and returns to the previous activity

Description:

This screen shows any harmonics present in the measurement circuit; for each phase, both the voltage and current harmonics can be seen. The current harmonics are shown as a bold red bar, and the voltage harmonics are shown as a thinner black bar.

The THD (Total Harmonic Distortion) for both voltage and current can be seen at the top right of each graph per phase.

5.4.1 Harmonics Details



Harmonic Analysis		Selected Site: None				
Harmonic Details						
Phase Currents						
HARM	SVa	SIa	SVb	SIb	SVc	SIc
0	0.0	0.0	0.0	0.0	0.0	0.0
1	100.0	100.0	100.0	100.0	100.0	100.0
2	0.1	0.3	0.1	0.1	0.1	0.2
3	0.0	0.1	0.1	0.0	0.1	0.1
4	0.0	0.1	0.1	0.0	0.0	0.0
5	0.0	0.0	0.0	0.0	0.0	0.0
6	0.0	0.0	0.0	0.0	0.0	0.0
7	0.0	0.0	0.0	0.0	0.0	0.0

Measurement: Live Test Sec V/Sec I, Instantaneous
Use Page Up/Down Keys to scroll through the data.

Graphs Interval Sec V/Pri I Amplitude Stop

Functionality:

F1	Displays the harmonic data as a bar graph per phase
F3	Toggles between Instantaneous, Interval, and Test Period (see Section 5 for details)
F4	Toggles between Sec V/Sec I, Sec V/Pri I, Pri V/Pri I and Neutrals (if correct probes are detected)
F5	Toggles the display units between % (of the fundamental) and amplitude (magnitude of volts and amps)
F6	Stops all active measurements and “freezes” the display enables F1 to manually save data

	Scrolls the screen up to the previous set of data (lower orders)
	Scrolls the screen down to the next set of data (higher orders)
	Closes the Harmonics Analysis screen and returns to the previous activity

Description:

This screen displays the harmonic content of the voltage and current signals for each phase. You can press F5 to toggle between reading the amplitude of the voltage and current harmonics, and changing to % of the fundamental.

Pressing F5 toggles the units displayed between percent of the fundamental (relative normalized amplitude) and the amplitude of the voltage and current.

Pressing the PAGE UP or PAGE DOWN keys scrolls up (toward lower orders) or down (toward higher orders) through the table.

The number of harmonics to display or save (0, 5, 20, 30, 50 or 100) is each specified independently in Preferences ([Section 9.7.3](#)).

A minimum threshold can also be specified which sets the minimum harmonic content to be saved. For example, if the minimum is set to 1% then any harmonic with amplitude less than 1% of the fundamental will not be saved. This helps prevent saving unnecessary data in the database.

5.5 Full Analysis

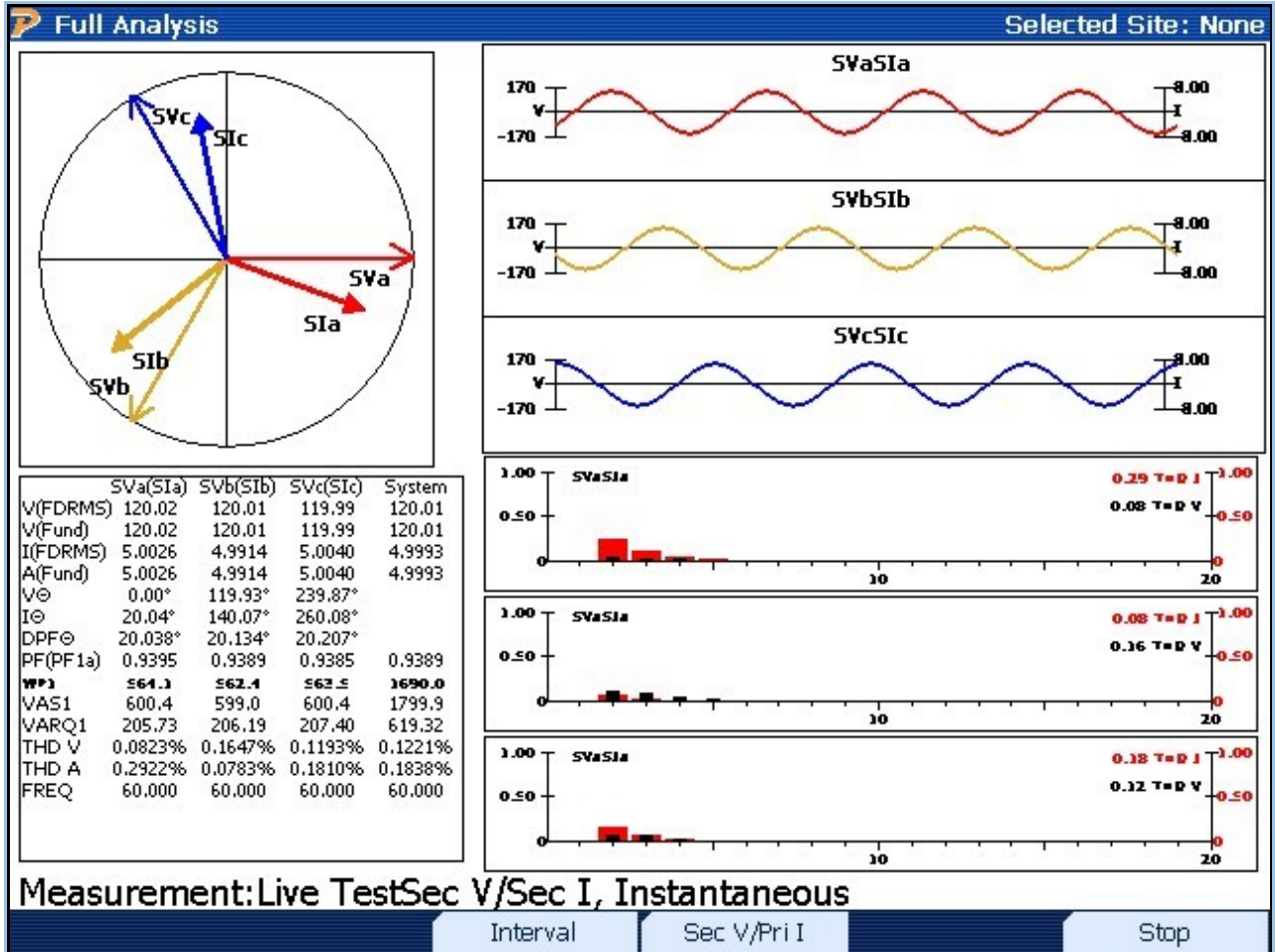

Functionality:

F3	Toggles between Instantaneous, Interval, and Test Period (see Section 5 for details)
F4	Toggles between Sec V/Sec I, Sec V/Pri I, Pri V/Pri I and Neutrals (if correct probes are detected)
F6	Stops all active measurements and “freezes” the display enables F1 to manually save data Data saved includes: waveforms, power meter, vector, and harmonics.
	Closes the Full Analysis screen and returns to the previous activity

Description:

This screen provides an efficient compact display of the entire power measurement system. The active measurements are listed at the bottom of the screen just like the individual screens.

5.6 Status Key

Description:

This screen provides a quick overview of the unit's condition. Function keys are available to access further details or perform a probe scan (see [Section 5.6.2](#)).

The "Active Measurements" shows which currents and voltages are detected on the attached probes and lead sets.

The "Power Status" displays the active state of the voltages from the internal components. If an indicator is green, the component is within tolerance. When red, the component is not actively reading voltage and may require repair. Contact Technical Support for more assistance.

Analyzer Status Selected Site: None

Active Site ID: None
Customer: None
Service Type: Auto Detect - S000F00.SRV
Date/Time: 4/10/2013 11:09:38 AM

<u>Active Measurements</u>				
	A	B	C	N
Sec V	●	●	●	●
Sec I	●	●	●	○
Pri V	○	○	○	○
Pri I	○	○	○	○

<u>Power Status</u>	
●	Auxiliary 12V
●	LCD Power
●	Analog Power
●	Digital Power

Probes Internals Software System Config DCO History Cal. History

Functionality:

F1	Runs "Probe Scan" to detect any probes connected to the unit (see Section 5.6.1)
F2	Displays internal voltages and temperatures
F3	Displays all current PowerMaster® software revisions
F4	Displays all configured options in the unit
F5	Displays the current engineering revision level of the unit
F6	Displays a rolling history of when the unit was calibrated
STATUS	Closes Status screen and returns to the previous activity

5.6.1 Software Revisions

Description:

This screen displays the current versions of all software components presently installed in the PowerMaster® unit along with a list of the installed options. It is accessed by pressing “F3” at the Status screen. You can return to the “Status” screen via “F1”.

The screenshot shows the 'Analyzer Status' screen with a blue header bar. The header contains a logo on the left and 'Selected Site: None' on the right. The main content area is white and contains two sections: 'Software Revisions' and 'Installed Options'. The 'Software Revisions' section lists various components and their versions. The 'Installed Options' section lists three options: 50 Amp, Ethernet, and Bar Code. At the bottom, there is a navigation bar with five buttons: 'Main', 'Internals', 'System Config', 'DCO History', and 'Cal. History'. The 'System Config' button is highlighted in dark blue.

<u>Software Revisions</u>	
Main Application:	1.0.1.9
WindowCE (BSP):	2.2.2.1.101008
Database:	2.2
Renderer:	1.0.1.9
PowerMasterGlobalData:	1.0.1.9
PowerMasterAPI:	2.2.1.0.130212
FPGA:	1.2.15
WFG Protocol:	1.1.3.9.24

Installed Options

- 50 Amp
- Ethernet
- Bar Code

Navigation Bar: Main | Internals | **System Config** | DCO History | Cal. History

5.6.2 Probe Scan

Description:

This screen displays which probes are required according to the current service type, and optionally to select a new service type. It is accessed via pressing “F1” on the status screen.

If any required probes are not detected there will be a red light next to the required probe(s) position. Connect the required probe and press Rescan (F2). When the probe is successfully detected, the light turns green.

Direct Inputs

The direct inputs are the voltage and current (“duckbills”) lead sets that are standard accessories to the PowerMaster®. On the connector panel (see 2.3 *Rear Panel*) they are labeled VOLTAGE and CURRENT. Direct inputs do not include any type of clamp-on probe, flexible probe, or high voltage probe.

Service Type

Displays the currently selected service type and allows selecting a new one. When the service type is changed a Probe Scan will automatically run and display the status of any required probes.

Color Key

GREEN	Probe is required and is successfully connected
RED	Probe is required but is not connected. Connect the correct probe and press Rescan
YELLOW	Probe is optional for use, but is not required
BLACK	Probe is not used for this service type

Probe Detection Results Selected Site: None

Service Type:

Direct Inputs:

- Secondary Voltage A
- Secondary Voltage B
- Secondary Voltage C
- Secondary Voltage Neutral
- Secondary Current A
- Secondary Current B
- Secondary Current C





Probe Set 1:

- Primary Current A NO PROBE
- Secondary Current Neutral NO PROBE
- Primary Current Neutral NO PROBE

Probe Set 2:

- Primary Voltage A NO PROBE
- Unused NO PROBE
- Unused NO PROBE

Functionality:

	Opens a drop-down box to select a service type. The drop down menu is only available when no site has been selected. If a site has been selected then "Service Type" will indicate the wiring from the Site Setup (Section 6.4.1)
	Moves between service types in the drop-down box
	Rescans the probes; used after a new probe is attached
	Continues

6 Site Manager

6.1 How Do I Select a Site

A Site is a database entry that the PowerMaster® 8 series uses to store all information about the meter that is being tested. Creating complete and accurate Sites will allow more detailed information to be stored, and will allow multiple users to understand the test that was performed. Sites can be created from the front panel, or created in Meter Site Manager 2 software, then downloaded to the PowerMaster® via USB connection. For information on using Meter Site Manager 2, please see the user manual that comes with it.

To begin using the Site Manager, verify the main menu appears as below. If a Site has already been selected, Option 5 will say “Deselect Site”. If the menu appears as below, press the button “2” on the front panel’s keypad to “Select Site”

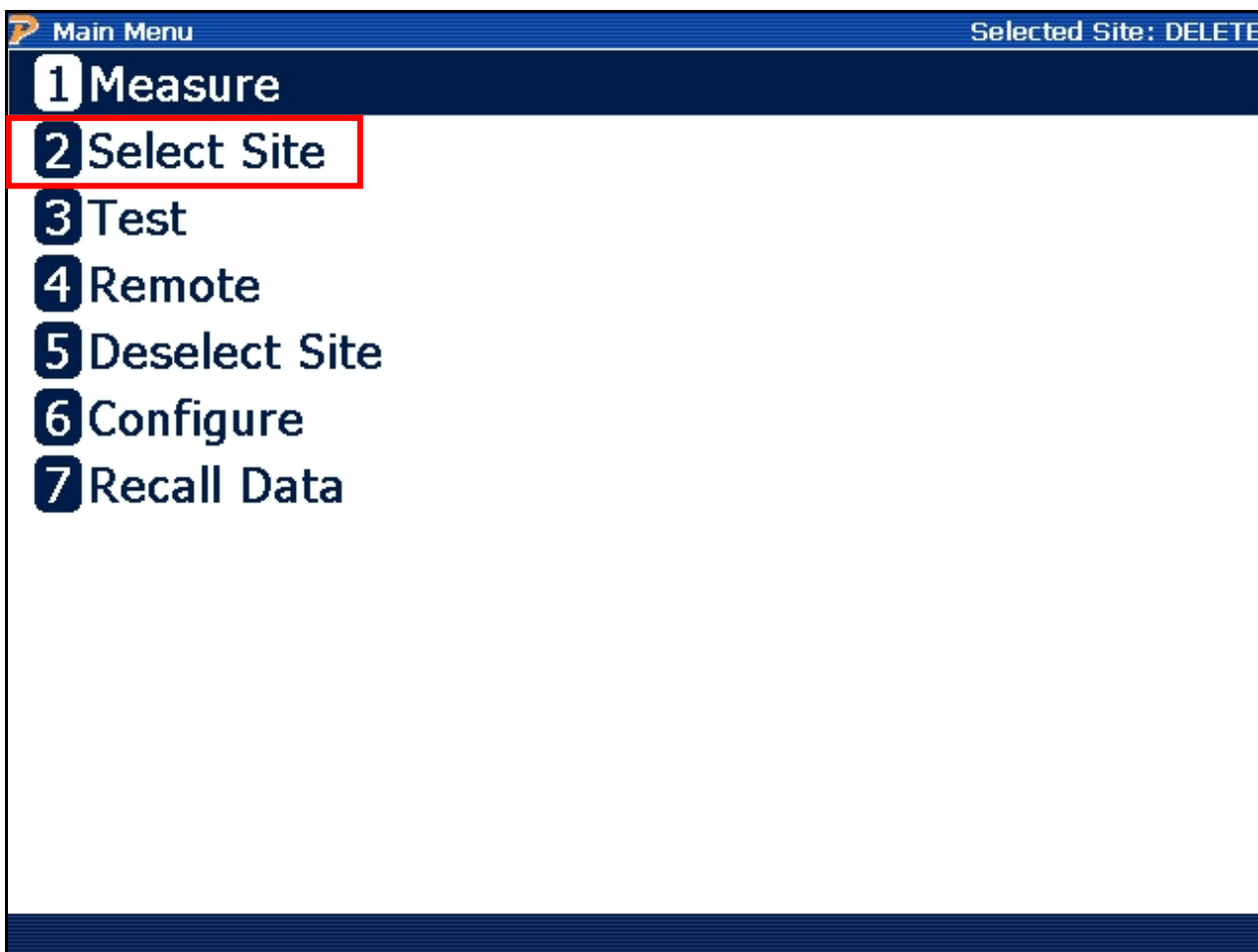

Once “2” has been pressed, the screen will change to show any available sites on the PowerMaster®, plus options to create a new site, edit a site, or delete a site.

Select Site Selected Site: DELETE



Select Site

SITE ID	CUSTOMER	ACCOUNT NO	MANUF SN	LAST TEST
DELETE				None



 A Listing of all Sites currently on the PowerMaster

New Site
Edit Site
Delete Site
Select

 	Moves cursor up and down to a preferred site
F2	Creates a new site in the database (see Section 6.2)
F3	Edits a pre-existing site in the database (see Section 6.4)
F4	Deletes a pre-existing site in the database (see Section 6.3)
F6	Selects the site and goes to the Main Menu (see Section 6.1)
PAGE UP	Goes up one page (available if sites exceed the first page)
PAGE DOWN	Goes down one page (available if sites exceed the first page)
PREV (END)	Returns to the Main Menu

6.2 How Do I Create a New Site

To create a new site, from the main menu Press or select “2”, then Press “F2” from the select Site Screen. In depth detail will be given in [Section 6.4.1](#).

The screenshot shows a software interface titled "Select Site". At the top right, it says "Selected Site: DELETE". Below the title is a table with the following columns: SITE ID, CUSTOMER, ACCOUNT NO, MANUF SN, and LAST TEST. The table contains one row with the value "DELETE" under SITE ID and "None" under LAST TEST. At the bottom of the screen, there are four buttons: "New Site", "Edit Site", "Delete Site", and "Select". A red arrow points to the "New Site" button, which is also highlighted with a red box.

SITE ID	CUSTOMER	ACCOUNT NO	MANUF SN	LAST TEST
DELETE				None

6.3 How Do I Delete a Site

From the “Select Site” screen, press “F4” to delete the site. Once deleted, all data and information associated with that site will be completely erased from the PowerMaster®.

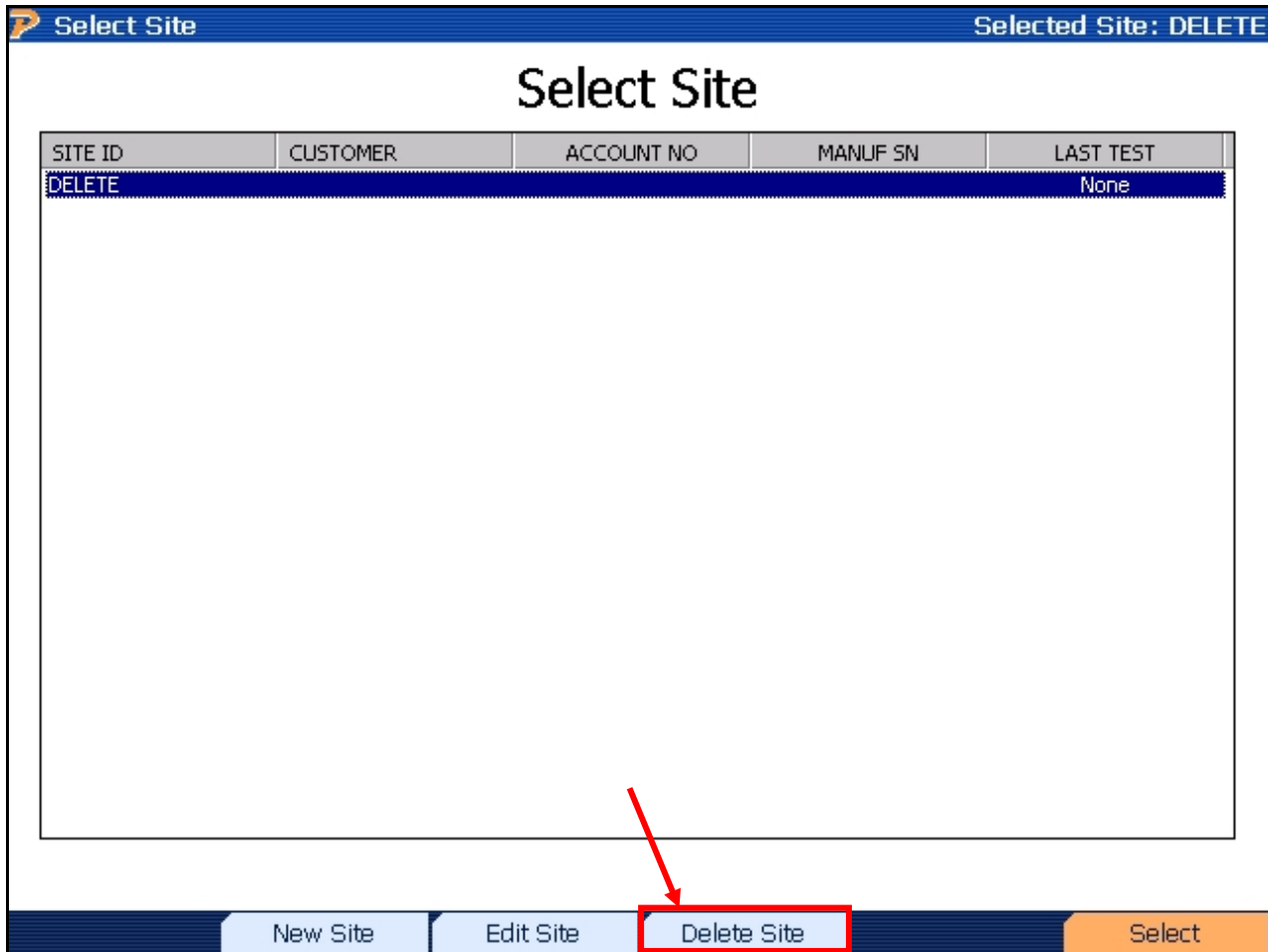

6.4 How Do I Edit a Site

From the “Select Site” screen, press “F3” to edit the site. This will allow all the information to be edited for the site, including the meter, the CT,s and PT,s and any Test associated with it.

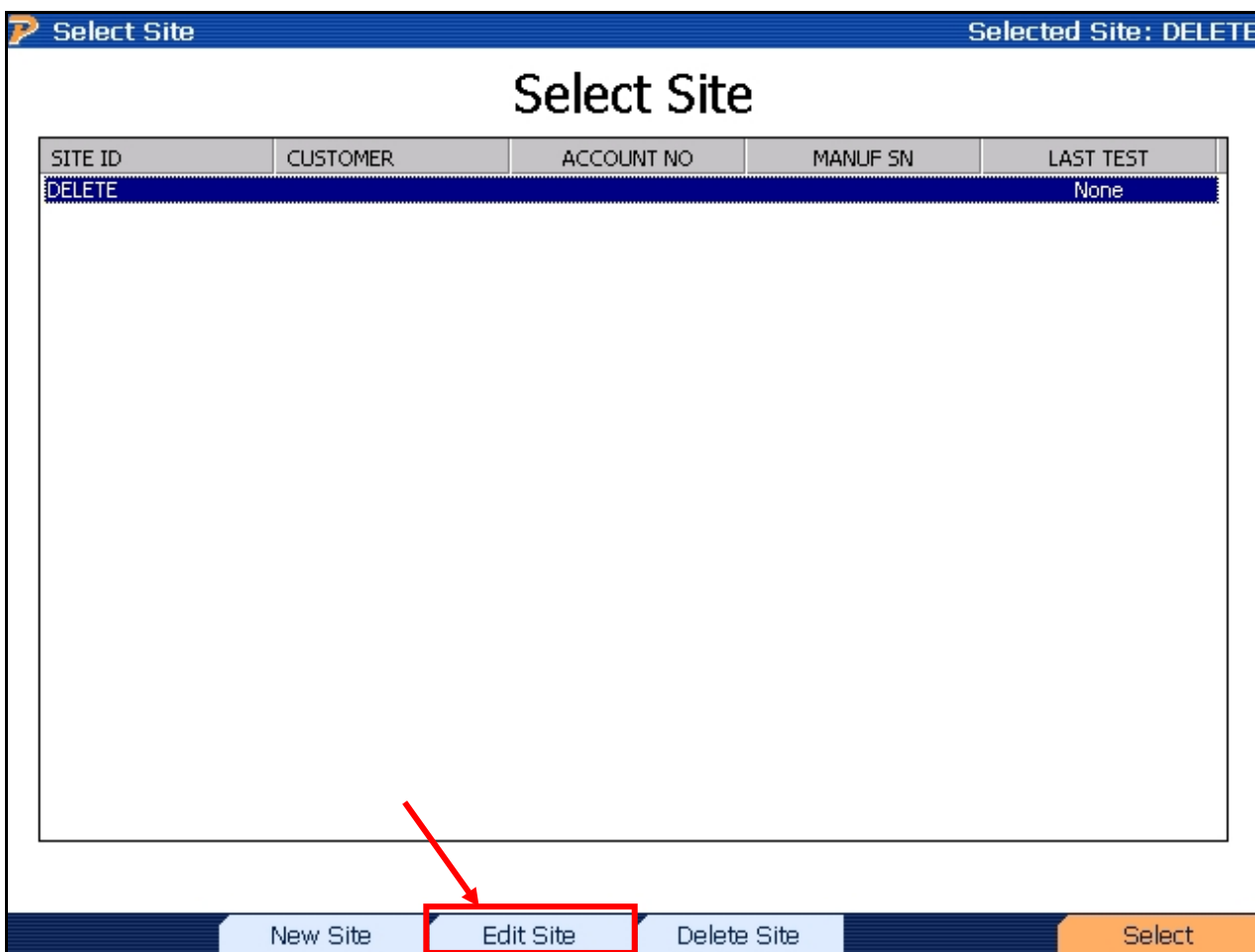

6.4.1 Details on Creating a New Site

Creating a site may be done either from the front panel of the PowerMaster®, or created in Meter Site Manager 2 and downloaded to the PowerMaster®. To use Meter Site Manager 2, follow the instructions in the software manual.

As mentioned in [Section 6.2](#), verify you are at the main menu and then press “2” to enter the “Select Site” screen. Press “F2” to create a new site from that screen.

Site Editor Selected Site: None

Site ID Kt

Meter Form Note: Enter Kt here to override the value from meter selection on Page 2.

Service

Service Type

Test Setup

Customer Substation

Account No Billing Mult

Address 1 Phone

Address 2 Locator

City Pri Volts

State/Prov Zip Next Test



Country



Section

Although there are only three fields required to create a site, it is recommended to fill in as much information as possible for accurate record keeping. The three required fields are:

1. Site ID: This field is a unique identifier for this particular site. It can be a name, a number, or a combination of the two.
2. Service Type: This identifies what the service type of the installation is. Such as 4-Wire Wye, 4 Wire Delta, etc.
3. Kt: The K factor of the meter. A reference standard that determines how many watt-hours per pulse are output from the meter. This field is not required if a meter has been selected on "Page 2". Explained more in [Section 6.4.2](#).

After the Site ID has been created, the next field is the meter form field. The meter form is listed on the nameplate of the meter and indicates which type socket and which wiring configuration the meter can be set for.

	This key "tabs" to the fields.
	Pressing this once opens a dropdown menu if there is one available.
	Use these keys to scroll up and down through the available menu options.

 	Pressing either of these keys will accept the highlighted selection.
---	--

With each selection, the remaining fields change to match the previous choice. Once the meter form has been selected, the Service and Service Type options are changed to what is acceptable for the selected meter form. For example, if a form 9 meter has been chosen, the “Service” field will show all appropriate forms of wiring for a Form 9 meter.

Once Meter Form and Service have been selected, the Service Type is the next field to enter. It shows the Service (3 Phase, 4-Wire Wye, etc) how many voltage and current transformers are available (3V, 3C) and if the meter is TR (Transformer Rated) or SC (Self Contained). A TR meter uses external PT's and CT's to read a scaled down version of the voltage and current, while a SC is a direct connected meter.

The Test Setup field allows the user to select which test to use for this particular site. More information on Test Editing/Creation is covered in [Section 6.4.1.1](#).

Once these fields have been selected, the Site Editor should resemble the picture below.

Site Editor Selected Site: None

Site ID Site Electric Information

Meter Form

Service

Service Type

Test Setup

Note: Enter Kt here to override the value from meter selection on Page 2.

Customer <input type="text"/>	Substation <input type="text"/>
Account No <input type="text"/>	Billing Mult <input type="text"/>
Address 1 <input type="text"/>	Phone <input type="text"/>
Address 2 <input type="text"/>	Locator <input type="text"/>
City <input type="text"/>	Pri Volts <input type="text"/>
State/Prov <input type="text"/>	Zip <input type="text"/>
Country <input type="text"/>	Next Test <input type="text" value="2013 Oct 14"/>

Section
Next Page
← "F2" for the next page.

The remaining fields, with the exception of Kt, are site specific information. Customer name or ID, account numbers, address, phone number, locator (gps coordinates) can all be entered here. None of these fields are required to run a test, but for record keeping it is recommended they are entered. The only other difference would be the Billing Multiplier. The **"Billing Multiplier"** is the CT Ratio (to 1) multiplied by the PT Ratio. (If no PT Ratio then use 1)

- Example: CT is 200:5. This becomes **40:1**
- If no PT is present then it becomes **40 * 1 = 40**
- If PT is 4:1 then the Multiplier becomes **4 * 40 = 160**

The "Next Test" field can be set for 6 months into the future, or a year into the future. This would be used to determine when this site needs to be re-tested.

The remaining field, "Kt" can either be entered on this page, or will be selected once the meter has been chosen. More details are the meter creation/editing is located in [Section 6.4.2](#).

6.4.1.1 Details on Creating and Editing a Test Setup

As mentioned above, the “Test Setup” field allows users to create and edit test setups. The PowerMaster® comes with two test built in that are called Default 1 and Default 2. These test cannot be edited or deleted.

To create a site specific test, “tab” to the “Test Setup” field. Once the Test Setup field is selected, “F4” shows a new tab called “Test Editor”. Press “F4” to enter the test editor field.

The screenshot shows the 'Site Editor' interface with the following fields and values:

- Site ID: 101
- Meter Form: 9
- Service: 4W-DELTA
- Service Type: 3-Phase, 4-Wire DELTA C-Hi (3V, 3C) TR - S010F09
- Test Setup: Default 1
- Customer: [Empty]
- Account No: [Empty]
- Address 1: [Empty]
- Address 2: [Empty]
- City: [Empty]
- State/Prov: [Empty]
- Country: [Empty]
- Substation: [Empty]
- Billing Mult: [Empty]
- Phone: [Empty]
- Locator: [Empty]
- Pri Volts: [Empty]
- Next Test: 2013 Oct 14
- Kt: [Empty]

A note on the right side states: "Note: Enter Kt here to override the value from meter selection on Page 2." At the bottom, a navigation bar contains buttons for 'Section', 'Next Page', and 'Test Editor'. The 'Test Editor' button is highlighted with a red box, and a red arrow labeled "F4" points to it.

Pressing “F4” takes you to the Test Editor screen. At this screen you can either select and edit any saved test (Except Default 1 and 2) or create a new test. To edit a test, highlight the drop down box at the “Test Setup” field and select the test to edit. To create a new test, Press “F2” for “New Setup”

Integrated Site Test Setup Selected Site: None

Test Setup **Default 1** ▼

Meter Tests

Customer Load

Test Mode **Wh** ▼

Do Demand Test

Test Time **0** Seconds Test Revs **3**

Phantom Load **NOTE: This unit cannot perform Phantom Load tests**

Phantom Load Setup **None** ▼

Transformer Testing

CT Test Mode **Burden + Ratio** ▼ Max Burden **0.5** ▼

Double Wrap

PT Test Mode: Ratio Only

Press "F2" to create a new site

New Setup Select

To edit a test, select from drop down menu then Press "F6"

Press "F2" to create a new site

After pressing "F2" a new screen will open that allows you to name your test, choose the options, and customize what is being performed.

Integrated Site Test Setup Selected Site: None

Using the keypad, enter the test name

Test Setup

Meter Tests

Customer Load

Test Mode ▾

Do Demand Test

Test Time Seconds Test Revs







Phantom Load NOTE: This unit cannot perform Phantom Load tests

Phantom Load Setup ▾

Transformer Testing

CT Test Mode ▾ Max Burden ▾

PT Test Mode: Ratio Only

	Use this key to tab to the fields
	Pressing this once opens a dropdown menu if there is one available. Also used to toggle checkboxes on and off
 	Use these keys to scroll up and down through the available menu options.
 	Pressing either of these keys will accept the highlighted selection.

Under the meter test sections, there are three checkboxes: Customer Load, Do Demand Test, and Phantom Load. For the PowerMaster[®] 8, Phantom Load is disabled, leaving only two options. Customer load is enabled when the check box is marked. There are three options for this type of test under the Test Mode drop down menu. The unit can be configured to test for watt hours (Wh), Volt-Amp hours (Vah), or Volt-Amp-Reactive hours (VARh). The most typical of these is the Wh test. During the test, the PowerMaster[®] will look for pulses indicating a watt hour has accrued. The amount of pulses required for the test to be completed is entered in the field called “Test Revs”. “Test Time” allows the user to set a maximum time for the test. The

PowerMaster® will continue to perform the test until one of the two conditions has been met. If it is desired to receive all pulses, set the time to a large number such as 9999.

Integrated Site Test Setup Selected Site: None

Test Setup Enter test Setup name here

Meter Tests

Customer Load

Test Mode Wh

Do Demand Test Enter total number of revs or pulses

Test Time 0 Seconds Test Revs 3

Time length of the test

Phantom Load NOTE: This unit cannot perform Phantom Load tests

Phantom Load Setup None

Transformer Testing

CT Test Mode Burden + Ratio Max Burden 0.5

PT Test Mode: Ratio Only

Cancel Save

The second half of the test involves testing any CT's and PT's that may be present. The PowerMaster® will only test the CT and PT if the appropriate checkboxes have been marked. On the CT test, there are three options under mode. A ratio test, a burden test, and a burden and ratio test. Additional accessories are needed to perform the ratio testing. For more details on the required CT's, please see [Section 11](#). For the ratio testing, the PowerMaster® measures Primary current and secondary current and verifies they are the correct ratio and phase angle.

The burden test allows the user to set a maximum burden under the "Max Burden" field. The PowerMaster® will induce a set of burdens to check the CT's ratings for burden. Internally the PowerMaster® will switch in various resistances to the current circuit and measure the current on the secondary to determine if the CT is within specifications.

Once all desired fields have been completed, pressing "F6" will save the test and return the user to the Site Editor screen. From the Site Editor screen, select the recently created test from the Test Setup field, then save the site. This test will now be associated with this site until changed manually.

6.4.2 Creating a New Site: Page 2

After creating a test and verifying that it is selected, proceed to Page 2 of the Site Editor. From the home "Site Editor" screen, press "F2" to proceed to the next page.

Site Editor Selected Site: None

Site ID Kt

Meter Form Note: Enter Kt here to override the value from meter selection on Page 2.

Service

Service Type

Test Setup

Customer Substation

Account No Billing Mult

Address 1 Phone

Address 2 Locator

City Pri Volts

State/Prov Zip Next Test

Country Press "F2" To proceed

Section **Next Page** Test Editor

Page 2 of the Site Editor allows the user to enter information about the meter under test at the selected site. The drop down menu contains a listing of meters that are stored in the database of the PowerMaster[®] 8. If the meter under test is not listed, see [Section 6.4.2.1](#) for information on adding a meter.

Site Editor Selected Site: None

Meter

	Mfr	Mdl	Cat#	Fr	Ty	Kt	Acc	Cl
Meter	None							
SN	None							
Meter No	EDMI, Mk6N Ge	2000-6N00	0	9S	TR	1.00	0.5	2
	Elster Elect	A1800	A1880RALN-X	9S	TR	0.10	0.2	1
	General Elec	KV	744X900001	9S	TR	1.80	0.2	2
	General Elec	KV2c	787X900001	9S	TR	1.80	0.2	2
	Landis + Gyr	Dialog	0	9S	TR	0.10	0.5	1
	Landis + Gyr	RXS4	7345UDFJG	9S	TR	1.80	0.2	2

AMR

Mfr | Mdl | Cat#

AMR

SN

Section | Next Page | Meter Editor

From the “Meter” drop down menu, various meters are listed. The meters contain the following information in their field.

- Mfr: Manufacture of the meter
- Mdl: Model name or number of the meter
- Cat#: Catalog number of the meter
- Fr: The meter form
- Ty: the type of meter, either TR(Transformer Rated) or SC(Self Contained)
- Kt: The K value of the meter. *Note* If a value is entered into the Kt field on Page one of the site editor, it will overwrite the “K” value selected on this screen
- Acc: This is the accuracy of the meter in %
- Cl: This is the current limit of the meter

If the meter is shown in the drop down menu, select it, if not follow the instructions on Section 6.4.2.1 to create a meter. There are four remaining fields left to be completed if desired. They are not needed to run a test, but recommended for record keeping purposes.

- SN: Serial Number of the meter under test
- Meter No: Identifying meter number
- Comm ID: If the meter is cellular capable, the phone number can be entered here

- IP Addr: If the meter is on a network, its IP address can be entered here.

Site Editor Selected Site: None

Meter

Mfr	Mod	Cat#	Fr	Ty	Rt	Acc	Cl
EDMI, Mk6N Ge	2000-6N00	0	9S	TR	1.00	0.5	▼

SN Comm ID

Meter No IP Addr

AMR

Mfr	Mod	Cat#
None		

SN

Section Next Page Meter Editor Save & Exit

At the bottom of the screen is a section to enter data for any AMR (Automatic Meter Reader) that may be present. The model may be selected via drop down menu, or if the AMR field is highlighted, pressing "F4" will allow access to the AMR Editor where one can be created.

Once the page is populated, pressing "F2" will proceed to the next page, or pressing "F6" will save the site and exit to the main menu.

6.4.2.1 Meter Editor: Creating or Editing a Meter

To access the “Meter Editor” verify that the visible screen is page 2 of the Site Editor, and that the “Meter” field is highlighted. With the “Meter” field highlighted, pressing “F4” will enter the meter editor screen.

Site Editor Selected Site: None

Verify Meter Field is highlighted

Meter

Mfr	Mod	Cat#	Fr	Ty	Rt	Acc	Cl
EDMI, Mk6N Ge	2000-6N00	0	9S	TR	1.00	0.5	

SN Comm ID

Meter No IP Addr

AMR

Mfr	Mod	Cat#
None		

SN

Press F4 to enter Meter Editor

Section Next Page Meter Editor Save & Exit

After pressing “F4” the Meter Editor screen appears. From this screen there are five choices that can be made.

Meter Editor - Showing Enabled Meter										Selected Site: None	
Enabled	Manufacturer	Model	Cat #	Acc	Form	Type	Class	TA-Hi	TA-Lo		
Yes	EDMI, Mk6N Genius	2000-6N00	0	0.5	95	TR	20	5	0.5		
Yes	Elster Electricity, LLC	A1800	A1880RALN-X	0.2	95	TR	10	5	0.5		
Yes	Fuji Dharma Electric	Meter Statik	FA14AI2E	1	25	SC	40	5	0.5		
Yes	General Electric	KV	744X100034	0.2	125	SC	320	30	3		
Yes	General Electric	KV	744X400001	0.2	165	SC	200	30	3		
Yes	General Electric	KV	744X400022	0.2	165	SC	320	30	3		
Yes	General Electric	KV	744X300001	0.2	35	TR	20	2.5	0.25		
Yes	General Electric	KV	744X300023	0.2	45	TR	20	2.5	0.25		
Yes	General Electric	KV	744X900001	0.2	95	TR	20	2.5	0.25		
Yes	General Electric	KV	744X600001	0.2	365	TR	20	2.5	0.25		
Yes	General Electric	KV	744X500001	0.2	455	TR	20	2.5	0.25		
Yes	General Electric	KV	745X300001	0.5	13A	SC	150	30	3		
Yes	General Electric	KV	745X400001	0.5	16A	SC	150	30	3		
Yes	General Electric	KV	745X000001	0.5	10A	TR	20	2.5	0.25		
Yes	General Electric	KV	745X600001	0.5	36A	TR	20	2.5	0.25		
Yes	General Electric	KV	745X500001	0.5	45A	TR	20	2.5	0.25		
Yes	General Electric	KV	745X800001	0.5	48A	TR	20	2.5	0.25		
Yes	General Electric	KV	744X200051	0.2	15	SC	200	30	3		
Yes	General Electric	KV	744X200001	0.2	25	SC	200	30	3		
Yes	General Electric	KV	744X200023	0.2	25	SC	320	30	3		
Yes	General Electric	KV	744X100001	0.2	125	SC	200	30	3		
Yes	General Electric	KV2c	787X200003	0.2	15	SC	200	30	3		
Yes	General Electric	KV2c	787X200001	0.2	25	SC	200	30	3		
Yes	General Electric	KV2c	787X200009	0.2	25	SC	320	30	3		
Yes	General Electric	KV2c	787X100001	0.2	125	SC	200	30	3		
Yes	General Electric	KV2c	787X100040	0.2	125	SC	320	30	3		
Yes	General Electric	KV2c	787X400001	0.2	165	SC	200	30	3		

- Disable: Accessed by pressing F1. This function “disables” the selected meter. Once a meter has been disabled, it will no longer show up in either the drop down menu, or this screen
- Show All: Accessed by pressing “F2”. This function shows all meters, including those that have been disabled
- New: Accessed by pressing “F3”. This function allows the creation of a new meter.
- Edit: Accessed by pressing “F4”. This function allows the selected meter to be edited.
- Select: Accessed by pressing “F6”. This function selects the highlighted meter as the meter to be tested, and returns to page 2 of “Site Editor”.

To add a new meter to the database, pressing “F3” will access the meter creation field. This allows the addition of meters that are not currently in the database but may be in the field.

Meter Editor - Showing Enabled Meter Selected Site: None

Enabled	Manufacturer	Model	Cat #	Acc	Form	Type	Class	TA-Hi	TA-Lo
Yes	EDMI, Mk6N Genius	2000-6N00	0	0.5	95	TR	20	5	0.5
Yes	Elster Electricity, LLC	A1800	A1880RALN-X	0.2	95	TR	10	5	0.5
Yes	Fuji Dharma Electric	Meter Statik	FA14AI2E	1	25	SC	40	5	0.5
Yes	General Electric	KV	744X100034	0.2	125	SC	320	30	3
Yes	General Electric	KV	744X400001	0.2	165	SC	200	30	3
Yes	General Electric	KV	744X400022	0.2	165	SC	320	30	3
Yes	General Electric	KV	744X300001	0.2	35	TR	20	2.5	0.25
Yes	General Electric	KV	744X300023	0.2	45	TR	20	2.5	0.25
Yes	General Electric	KV	744X900001	0.2	95	TR	20	2.5	0.25

Manufacturer: Model:
 Cat #: TA-Hi: TA-Lo:
 Accuracy Class: Voltage:
 Form: Type:
 Kt: Frequency:
 Style: Demand Period:
 Enabled:

Save

When creating a new meter, there are 15 fields which can accept data.

- Manufacturer: The maker of the meter under test
- Cat #: The catalog number of the meter under test
- Accuracy class: The accuracy of the meter under test
- Form: The meter form of the meter under test
- Type: Either TR(Transformer Rated) or SC(Self Contained)
- Kt: K factor of the meter under test
- Frequency: Selectable between either 50 or 60Hz. Indicates the frequency of the line voltage
- Style: Selectable between ANSI (American National Standards Institute) or IEC (International Electrotechnical Commission).
- Model: The model number or name of the meter under test
- TA-Hi: The high end of the test amps for the meter under test
- TA-Lo: the low end of the test amps for the meter under test
- Voltage: Voltage rating of the meter under test
- Current class: Indicates the current class of the meter under test

- Demand Period: The interval during which time demand is measured. Determined by the billing tariff for a rate schedule.
- Enabled: Must be set to yes for the meter to show up in the drop down menu.

Once the information has been entered, pressing “F6” will save the new meter and return to the Meter Editor page. Highlight the recently created meter and press “F6” to return to Page 2 of the site editor.

6.4.3 Creating a New Site: Page 3

Site Editor
Selected Site: None

When checked all CT's will be the same value

CT	Mfr	Model	Cat#	NPR:	Same
CT-A	GEC Durham I	TCW1	197KBRP	100	<input checked="" type="checkbox"/>
CT-B	GEC Durham I	TCW1	197KBRP	100	<input type="checkbox"/>
CT-C	GEC Durham I	TCW1	197KBRP	100	<input type="checkbox"/>

SN-A

SN-B

SN-C

PT	Mfr	Model	Cat#	NPR: 1	Same
PT-A	GEC Durham I	DF1	1071	1	<input checked="" type="checkbox"/>
PT-B	GEC Durham I	DF1	1071	1	<input type="checkbox"/>
PT-C	GEC Durham I	DF1	1071	1	<input type="checkbox"/>

SN-A

SN-B

SN-C

Section
Next Page
Save & Exit

Functionality:

F1	Quickly moves to the next most important section
F2	Moves to the next page
F3	Displays the CT Editor and PT Editor when selected
F6	Saves and exits the Site Editor form
PREV (END)	Backs up to Site Editor page 2

Page 3 of the site editor allows the user to select the CT's and PT's that are present in the system. Using the drop down menu, users can select pre-created CT's or PT's, or by highlighting the field, can press "F4" to enter the CT or PT editors. If the box beside the drop down fields labeled "Same" is checked, then it will match the remaining fields to the one selected.

While browsing the drop down menu, there are four identifiers present.

- Mfr: The manufacturer of the CT/PT
- Model: The model/model number of the CT/PT
- Cat#: The catalog number of the CT/PT
- NPR: The name plate rating of the CT/PT. For CT's it is to 5(value of 100 = 100:5) and for PT's it is to 1(value of 100 = 100:1)

The serial numbers can also be entered into the fields at this time.

6.4.4 Creating a New Site (Page 4)

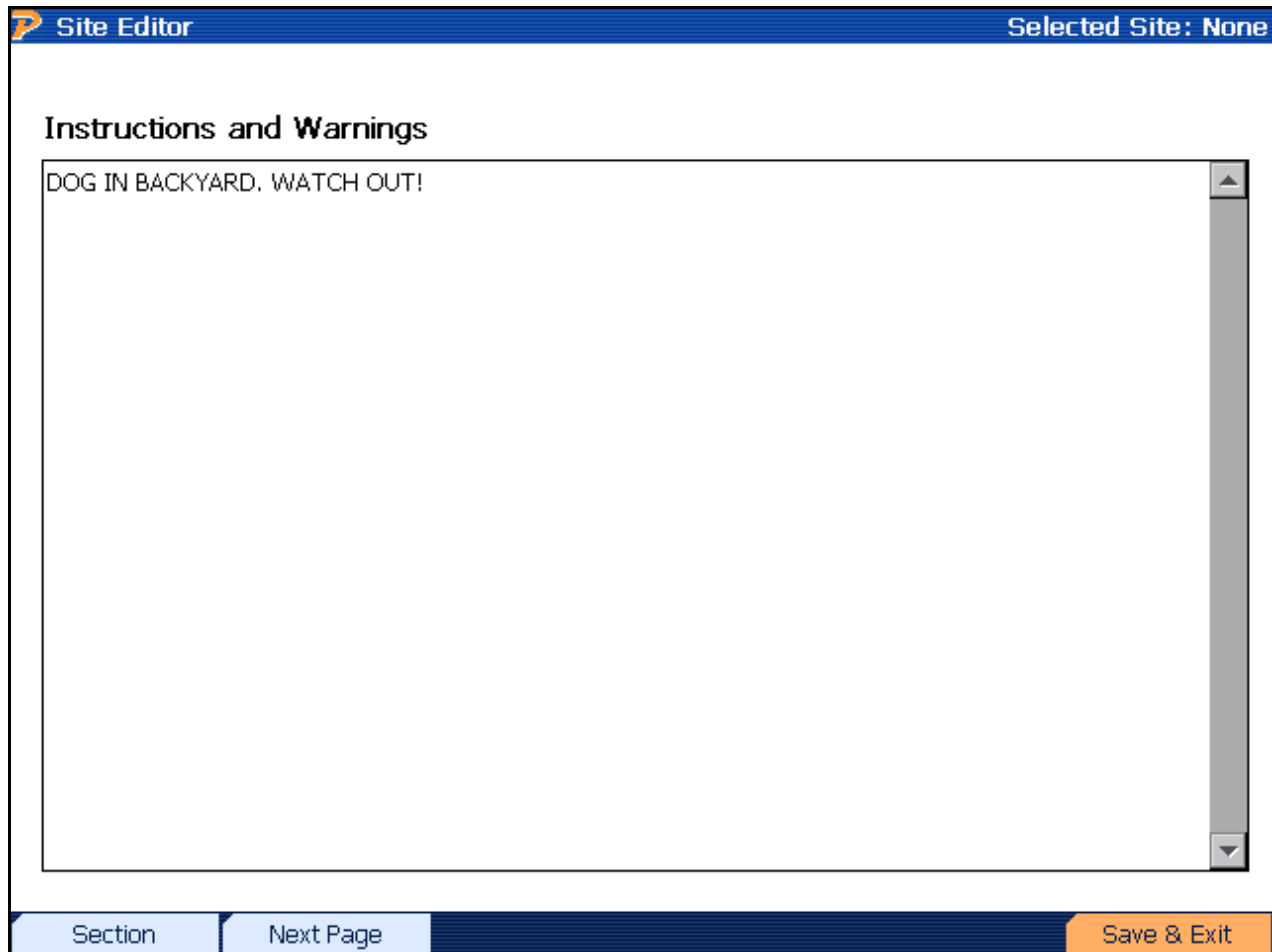

Functionality:

	Quickly moves to the next most important section
---	--

F2	Moves to the next page
F6	Saves and exits the Site Editor form
PREV (END)	Backs up to Site Editor page 3

Description:

This screen allows the user to enter notes and comments about the site installation before testing begins.

6.4.5 Creating a New Site (Page 5 & 6)

The screenshot shows the 'Site Editor' interface with a blue header bar containing 'Site Editor' on the left and 'Selected Site: None' on the right. Below the header, the text 'Custom Fields (Page 1 of 2)' is displayed. The main area contains a grid of 30 input fields, each labeled 'User' followed by a number from 1 to 30, arranged in three columns of ten. At the bottom of the interface is a dark blue navigation bar with three buttons: 'Section' (light blue), 'Next Page' (light blue), and 'Save & Exit' (orange).

Functionality:

F1	Quickly moves to the next most important section
F2	Moves to the next page

F6	Saves and exits the Site Editor form
PREV (END)	Backs up to Site Editor page 4

Description:



These screens allow the user to enter up to 60 custom fields that are directly associated with the site. The interface to change the names of the fields can be found in the User Preferences.

6.4.5.1 PT Editor

PT Editor - Showing Enabled PT								Selected Site: HIGH SCHOOL
Enabled	Manufacturer	Model	Cat #	Acc Class	Bur Class	NPR	RV	
Yes	Itron	T5R	92357-101	0.3	W 12.5...	1	120	
Yes	Itron	T5R	92357-201	0.3	W 12.5...	2	240	
Yes	Itron	T5R	92357-241	0.3	W 12.5...	2.4	288	
Yes	Itron	T5R	92357-251	0.3	W 12.5...	2.5	300	
Yes	Itron	T5R	92357-401	0.3	W 12.5...	4	480	
Yes	Itron	T5R	92357-501	0.3	W 12.5...	5	600	
Yes	Itron	T6R	92358-101	0.3	M 35.0 ...	1	120	
Yes	Itron	T6R	92358-201	0.3	M 35.0 ...	2	240	
Yes	Itron	T6R	92358-241	0.3	M 35.0 ...	2.4	288	
Yes	Itron	T6R	92358-251	0.3	M 35.0 ...	2.5	300	
Yes	Itron	T6R	92358-401	0.3	M 35.0 ...	4	480	
Yes	Itron	T6R	92358-501	0.3	M 35.0 ...	5	600	
Yes	Itron	T7R	92359-101	0.3	Y 75.0 VA	1	120	
Yes	Itron	T7R	92359-201	0.3	Y 75.0 VA	2	240	
Yes	Itron	T7R	92359-241	0.3	Y 75.0 VA	2.4	288	
Yes	Itron	T7R	92359-251	0.3	Y 75.0 VA	2.5	300	
Yes	Itron	T7R	92359-401	0.3	Y 75.0 VA	4	480	
Yes	Itron	T7R	92359-501	0.3	Y 75.0 VA	5	600	
Yes	The Durha...	DB1	1051	0.3	M 35.0 ...	1	120	
Yes	The Durha...	DB2	1052	0.3	M 35.0 ...	2	240	
Yes	The Durha...	DB2.4	1053	0.3	M 35.0 ...	2.4	288	
Yes	The Durha...	DB2.5	1054	0.3	M 35.0 ...	2.5	300	
Yes	The Durha...	DB4	1055	0.3	M 35.0 ...	4	480	
Yes	The Durha...	DF1	1071	0.3	W 12.5...	1	120	
Yes	The Durha...	DF2	1072	0.3	W 12.5...	2	240	
Yes	The Durha...	DF2.4	1073	0.3	W 12.5...	2.4	288	
Yes	The Durha...	DF2.5	1074	0.3	W 12.5...	2.5	300	
Yes	The Durha...	DF4	1075	0.3	W 12.5...	4	480	

Buttons: Disable, Show All, New, Edit, Delete, Select

Functionality:

 	Moves cursor up and down for selecting a PT (voltage transformer)
F1	Disables the selected PT (see Section 6.4.5.2)
F2	Shows all enabled and disabled PT's in database (default = enabled only)

F3	Creates a new PT (see Section 6.4.5.2)
F4	Opens the selected PT to be edited (see Section 6.4.5.2)
F5	Deletes the selected PT (see Section 6.4.5.2)
F6	Selects the PT for the site and exits (see Section 6.4.5.2)

6.4.5.2 Creating or Editing a PT

PT Editor - Showing Enabled PT Selected Site: HIGH SCHOOL

Enabled	Manufacturer	Model	Cat #	Acc Class	Bur Class	NPR	RV
Yes	Itron	T5R	92357-101	0.3	W 12.5...	1	120
Yes	Itron	T5R	92357-201	0.3	W 12.5...	2	240
Yes	Itron	T5R	92357-241	0.3	W 12.5...	2.4	288
Yes	Itron	T5R	92357-251	0.3	W 12.5...	2.5	300
Yes	Itron	T5R	92357-401	0.3	W 12.5...	4	480
Yes	Itron	T5R	92357-501	0.3	W 12.5...	5	600
Yes	Itron	T6R	92358-101	0.3	M 35.0 ...	1	120
Yes	Itron	T6R	92358-201	0.3	M 35.0 ...	2	240
Yes	Itron	T6R	92358-241	0.3	M 35.0 ...	2.4	288
Yes	Itron	T6R	92358-251	0.3	M 35.0 ...	2.5	300
Yes	Itron	T6R	92358-401	0.3	M 35.0 ...	4	480
Yes	Itron	T6R	92358-501	0.3	M 35.0 ...	5	600
Yes	Itron	T7R	92359-101	0.3	Y 75.0 VA	1	120
Yes	Itron	T7R	92359-201	0.3	Y 75.0 VA	2	240

Manufacturer:

Model:

Cat #:

Accuracy Class:

Burden Class:







Nameplate Ratio:

Rated Voltage:

Enabled:

Save









Functionality:

 	Moves cursor up and down for selecting a PT and for selecting options in the drop down boxes
	Moves to next field
	Moves to previous field
	Enters drop down box
	Saves changes and exits
	Backs up to PT Editor (Section 6.4.5.1)

6.4.6 CT Editor

CT Editor - Showing Enabled CT								Selected Site: HIGH SCHOOL
Enabled	Manufacturer	Model	Cat #	RF	Acc Class	Bur Class	NPR:5	
Yes	Itron	R6BA	92353-050	3	0.3	0.2	200	
Yes	Itron	R6BA	92353-055	4	0.3	0.2	100	
Yes	Itron	R6BA	92353-056	4	0.3	0.2	100	
Yes	Itron	R6BA	92353-058	4	0.3	0.2	100	
Yes	Itron	R6BA	92353-220	4	0.3	0.1	100	
Yes	Itron	R6L	92356-001	2	0.3	0.5	800	
Yes	Itron	R6L	92356-101	2	0.3	0.5	800	
Yes	Itron	R6L	92356-002	2	0.3	0.5	1000	
Yes	Itron	R6L	92356-102	2	0.3	0.5	1000	
Yes	Itron	R6L	92356-003	2	0.3	0.9	1200	
Yes	Itron	R6L	92356-103	2	0.3	0.9	1200	
Yes	Itron	R6L	92356-004	3	0.3	0.9	1500	
Yes	Itron	R6L	92356-104	3	0.3	0.9	1500	
Yes	Itron	R6L	92356-005	2	0.3	1.8	2000	
Yes	Itron	R6L	92356-105	2	0.3	1.8	2000	
Yes	Itron	R6L	92356-006	1.5	0.3	1.8	3000	
Yes	Itron	R6L	92356-106	1.5	0.3	1.8	3000	
Yes	Itron	R6L	92356-007	1.33	0.3	1.8	4000	
Yes	Itron	R6L	92356-107	1.33	0.3	1.8	4000	
Yes	Itron	R6L	92356-008	2	0.3	0.2	600	
Yes	Itron	R6L	92356-008(...	2	0.3	0.9	1200	
Yes	Itron	R6L	92356-108	2	0.3	0.2	600	
Yes	Itron	R6L	92356-108(...	2	0.3	0.9	1200	
Yes	Itron	R6L	92356-009	2	0.3	0.5	800	
Yes	Itron	R6L	92356-009(...	2	0.3	0.9	1600	
Yes	Itron	R6L	92356-109	2	0.3	0.5	800	
Yes	Itron	R6L	92356-109(...	2	0.3	0.9	1600	
Yes	Itron	R6L	92356-010	2	0.3	0.5	1000	

Functionality:

 	Moves cursor up and down for selecting a CT (current transformer)
	Disables the selected CT (see Section 6.4.6.1)
	Shows all enabled and disabled CT's in database (default = enabled only)
	Creates a new CT (see Section 6.4.6.1)
	Opens the selected CT to be edited (see Section 6.4.6.1)
	Deletes the selected CT (see Section 6.4.6.1)
	Selects the CT for the site and exits

6.4.6.1 Creating or Editing a CT

CT Editor - Showing Enabled CT Selected Site: HIGH SCHOOL

Enabled	Manufacturer	Model	Cat #	RF	Acc Class	Bur Class	NPR:5
Yes	Itron	R6BA	92353-050	3	0.3	0.2	200
Yes	Itron	R6BA	92353-055	4	0.3	0.2	100
Yes	Itron	R6BA	92353-056	4	0.3	0.2	100
Yes	Itron	R6BA	92353-058	4	0.3	0.2	100
Yes	Itron	R6BA	92353-220	4	0.3	0.1	100
Yes	Itron	R6L	92356-001	2	0.3	0.5	800
Yes	Itron	R6L	92356-101	2	0.3	0.5	800
Yes	Itron	R6L	92356-002	2	0.3	0.5	1000
Yes	Itron	R6L	92356-102	2	0.3	0.5	1000
Yes	Itron	R6L	92356-003	2	0.3	0.9	1200
Yes	Itron	R6L	92356-103	2	0.3	0.9	1200
Yes	Itron	R6L	92356-004	3	0.3	0.9	1500
Yes	Itron	R6L	92356-104	3	0.3	0.9	1500
Yes	Itron	R6L	92356-005	2	0.3	1.8	2000

Manufacturer:

 Model:







 Catalog #:
 Accuracy Class:

 Burden Class:
 Nameplate Ratio: :5

 Rating Factor:
 Enabled:

Save

Functionality:

	Moves cursor up and down for selecting a PT and for selecting options in the drop down boxes
	Moves to next field
	Moves to previous field
	Enters drop down box
	Saves changes and exits
	Backs up to CT Editor (Section 6.4.6)

7 Test

To begin a test, from the main menu select the preselected site. If no site exist, see Section 6 to setup a site and a test. Once a site has been selected, the main menu appears as below.

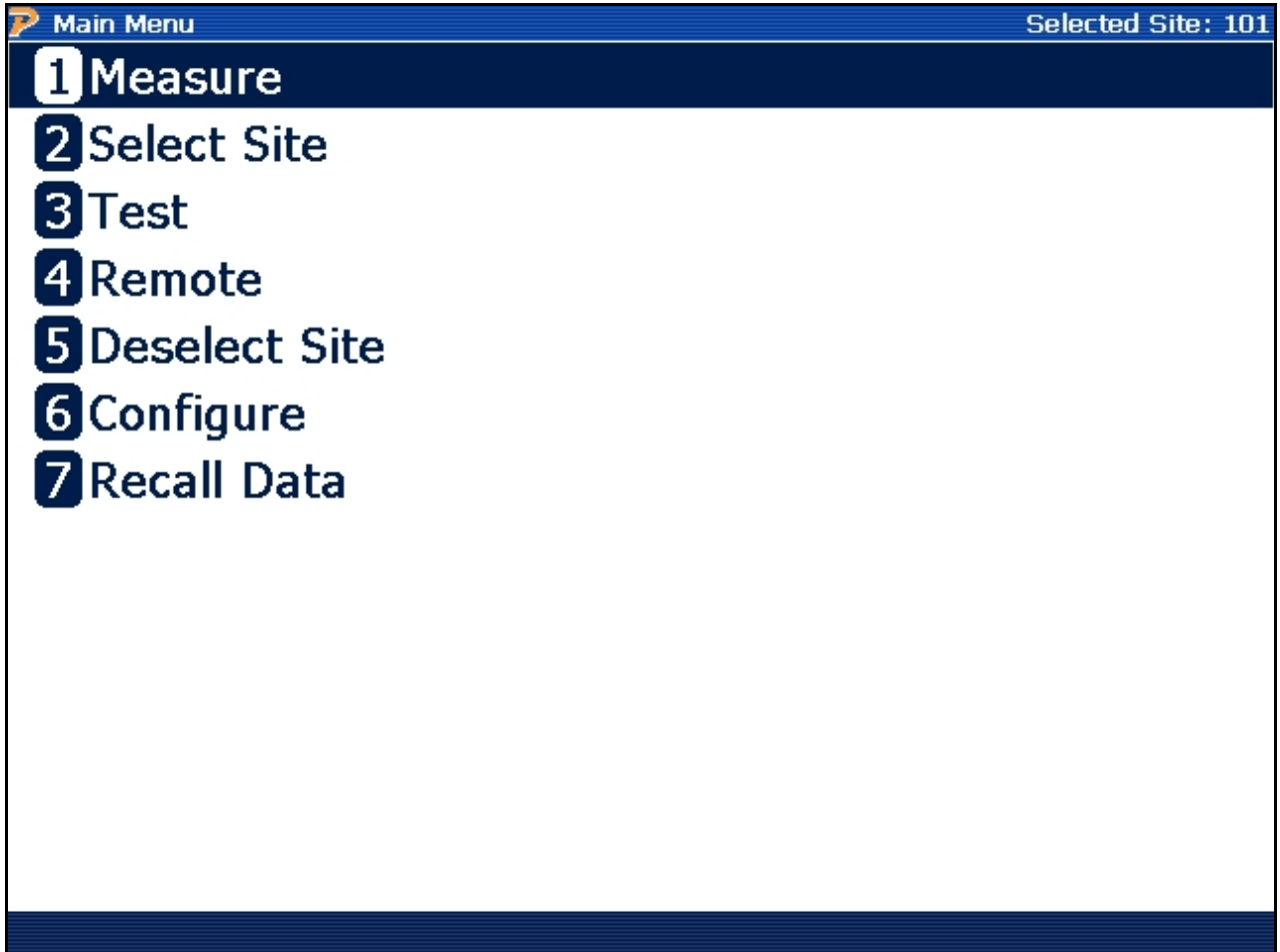

There will be an extra selection on the main menu. Option 5 will only show up as “Deselect Site” if a site is selected. To edit the site, the site must be de-selected and the steps in Section 6 followed.

To begin the test process, select the option for “3” Test”.

The next screen that loads has four options.

7.1 Test Menu

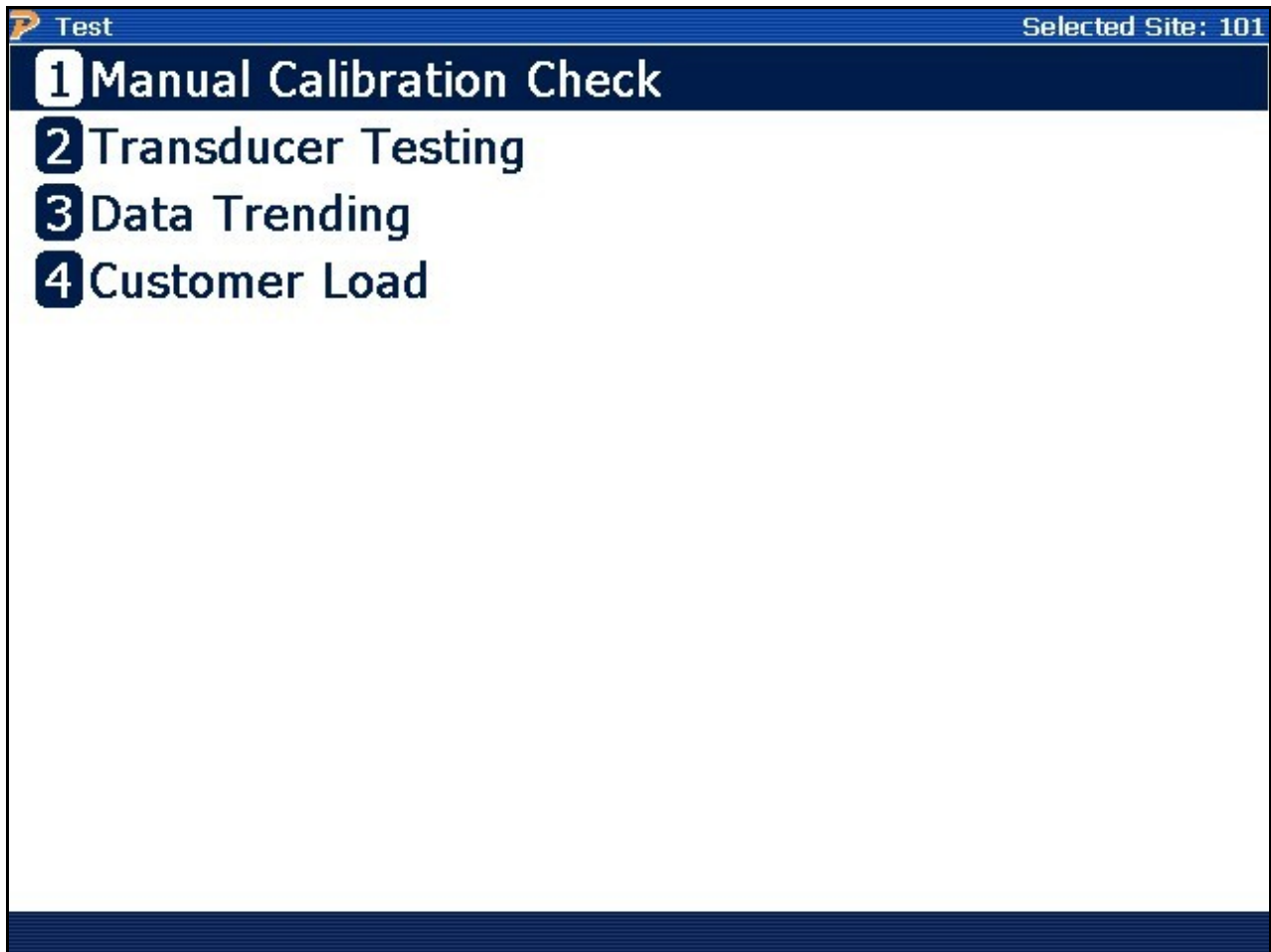

1. Manual Calibration: This option allows the user to do a quick test to verify the meter under test is calibrated. User can enter Kt, test seconds, and if testing for Wh, Vah, or VARh.
2. Transducer Testing: With a source voltage or current, allows the user to record the output signal of a transducer.
3. Data Trending: Allows trend data to be taken for later analysis.
4. Customer Load: This option allows the user to perform the pre-designed test stored in the selected sites database. This is the option to select to begin site testing.

7.2 Manual Calibration Check

Calibration Check Selected Site: SITE1







Compare to Standard

Standard (Kt)

Test Seconds

Energy Test Mode

Functionality:

	Moves to next field
	Moves to previous field
	Enters drop down box and views test mode selections; checks/unchecks check boxes
 	Moves cursor up and down for selecting a test mode in the drop down box
	Continues

Description:

This feature can perform a cross-check against the user's shop standard to verify the accuracy. Enter the Kh value of the shop standard into the field for "Standard (Kt)". Remember if the standard is single phase and you have the system hooked up series-parallel then you need to

multiply the standard Kt by three (3). The user can also enter the desired test time and energy test mode (Wh, VAh, and VARh). When selecting the Energy Test Mode, verify the shop standard is correctly matched to the PowerMaster's® energy test mode.

Using Standard Voltage and Current Cables with the PowerMaster®

What Do I Need?

1. PowerMaster® unit
2. Standard current and voltage leads
3. PowerMaster® External Digital Cable (separate accessory)
4. External power supply (current and voltage source)
5. Whr/VAhr/VARhr standard
6. AC adapter with a "pigtail" termination (line & neutral bare wires)
7. 10-terminal test switch
8. 18+ AWG wire for voltage and 12+ AWG wire for current

Hookup Instructions:

1. From the external power supply, connect the voltage output to the A phase potential on the test switch
2. From the external power supply, connect the voltage output return to the N phase potential on the test switch.
3. From the test switch, connect the N phase potential to a known earth ground.
4. From the test switch, connect a jumper wire from A potential to B potential. Connect another jumper wire from B potential to C potential. This creates a parallel circuit for the voltage.
5. From the W-hr/Var-hr standard, connect the line voltage to the A phase potential on the test switch.
6. From the W-hr/Var-hr standard, connect the neutral voltage to the N phase potential on the test switch.
7. From the external power supply, connect the current output to the bottom of the A phase current on the test switch.
8. From the external power supply, connect the current output return to the "current out" of the W-hr/Var-hr standard.
9. From the W-hr/Var-hr standard, connect the "current in" of the W-hr/Var-hr standard to the C phase current return on the test switch.
10. From the test switch, a) connect a jumper wire from the top of the A phase current to the top of the A phase current return. From the bottom of the A phase current return, b) connect a jumper wire to the bottom of B phase current. From the top of B phase current, c) connect a jumper wire to the top of B phase current return. From the bottom of B phase current return, d) connect a jumper wire to the bottom of C phase current. From the top of C phase current, e) connect a jumper wire to the top of C phase current return. This creates a series circuit for the current.
11. From the PowerMaster®, connect the VOLTAGE leads to the voltage potentials on the test switch (A=red, B=yellow, C=blue, N=white). Connect the green safety ground lead to the N phase potential on the test switch.

12. From the PowerMaster[®], insert the CURRENT leads into the current return phases on the test switch (A=red, B=yellow, C=blue).
13. From the PowerMaster[®] DIGITAL input, connect the External Digital Cable (STD IN) to the pulse output on the W-hr/Var-hr standard.
14. From the PowerMaster[®], connect the AUX PWR and AUX NEU to a voltage source between 100-530VAC to power the analyzer (recommended).
15. From the W-hr/Var-hr standard, use the AC adapter to connect the auxiliary power from the standard.

Procedure:

1. Verify all connections according to the hookup instructions and wiring diagram.
2. Using the external power supply, select the desired voltage, current, and power factor for the test. This will be a series-parallel load.
3. At the Calibration Check screen, select the correct energy test mode (W-hr, VAR-hr, or VA-hr) and enter the desired time and Kh value of the standard. When using a series parallel load, the Kh value should be multiplied by 3 (ex. $0.00001 * 3 = 0.00003$)
4. Press F6 (Start Test) to begin the test.
5. View and record results.
6. Press PREV to return to the Calibration Verification menu.

Using the Calibration Cable Set with the PowerMaster[®]

What Do I Need?

1. PowerMaster[®] unit
2. PowerMaster[®] Calibration Cables Kit
3. PowerMaster[®] External Digital Cable (separate accessory)
4. External power supply (current and voltage source)
5. W-hr/Var-hr standard
6. AC adapter with a "pigtail" termination (line & neutral bare wires)
7. 18+ AWG wire for voltage and 12+ AWG wire for current

Hookup Instructions:

1. From the PowerMaster[®], connect the one end of the Voltage calibration cable to line (red) and neutral (black) of the W-hr/Var-hr standard.
2. From the PowerMaster[®], connect the other end of the Voltage calibration cable to the external power supply (red = V out HI, white = V out LO, yellow = V sense HI, blue = V sense LO). Connect the ground (green) to a known earth ground.
3. From the PowerMaster[®], connect the Current calibration cable for line (red) to the W-hr/Var-hr standard's current return. Then, connect the neutral (black) to the external power supply's current output neutral (LO).
4. From the external power supply, connect the current output (HI) to the W-hr/Var-hr standard's current.
5. From the PowerMaster[®] DIGITAL input, connect the External Digital Cable (STD IN) to the pulse output on the W-hr/Var-hr standard.

6. From the PowerMaster®, connect the AUX PWR and AUX NEU to a voltage source between 100-530VAC to power the analyzer (recommended).
7. From the W-hr/Var-hr standard, use the AC adapter to connect the auxiliary power from the standard.

Procedure:

1. Verify all connections according to the hookup instructions and wiring diagram.
2. Using the external power supply, select the desired voltage, current, and power factor for the test. This will be a series-parallel load.
3. At the Calibration Check screen, select the correct energy test mode (W-hr, Var-hr, or Va-hr) and enter the desired time and Kh value of the standard. When using a series parallel load, the Kh value should be multiplied by 3 (ex. $0.00001 * 3 = 0.00003$)
4. Press F6 (Start Test) to begin the test.
5. View and record results.

Press PREV to return to the Calibration Verification menu.

7.3 Transducer Testing

Option 2, Transducer Testing, allows a user to connect to the output of a voltage or current transformer, and via the transducer test cable, and the Aux Digital port, verify the unit is operating correctly.

1. Verify there is voltage or current available on the input of the transducer.
2. Connect the Aux Digital Cable to the output of the transducer. Ensure that current is used only for current outputs, and voltage only for voltage outputs.
3. Enter the transducer type, serial number, and if applicable the service type.
4. From the transducer nameplate, insert the input range in the appropriate fields, then using the drop down menu, select the unit of measure. Example: 0-150V, or 0-5A
5. From the transducer nameplate, insert the output range in the appropriate fields, then using the drop down menu, select the unit of measure. Example: 0-5Vdc, or 4-20mA.
6. Apply voltage or current to the input of the transducer.

Transducer Test
Selected Site: None

Transducer None Default
 Serial No 1
 Service Type Auto Detect - S000F00
 Input Range 0 To 150 V
 Output Range 0 To 5 V

Registration 100.43%

	<u>Instantaneous</u>
Transducer V	4.0172
PowerMaster V	119.9978

Stop
Error

The testing will continue until "F1" is pressed. Pressing "F6" toggles the display between Registration, and Error for values.

7.4 Data Trending

Pressing 3 from the "Test" menu opens up the Data Trending software.

Data Trending Setup Selected Site: 101

Time Interval Seconds

Total Time : : (hh:mm:ss)

Event (High) % Low %

Display Signals
Select up to 6 to view; all are recorded

	A	B	C	Sys
PV	<input type="checkbox"/>	<input type="checkbox"/>	<input type="checkbox"/>	<input type="checkbox"/>
SV	<input checked="" type="checkbox"/>	<input checked="" type="checkbox"/>	<input checked="" type="checkbox"/>	<input type="checkbox"/>
PI	<input type="checkbox"/>	<input type="checkbox"/>	<input type="checkbox"/>	<input type="checkbox"/>
SI	<input type="checkbox"/>	<input type="checkbox"/>	<input type="checkbox"/>	<input type="checkbox"/>
W	<input type="checkbox"/>	<input type="checkbox"/>	<input type="checkbox"/>	<input type="checkbox"/>
VA	<input type="checkbox"/>	<input type="checkbox"/>	<input type="checkbox"/>	<input type="checkbox"/>
VAR	<input type="checkbox"/>	<input type="checkbox"/>	<input type="checkbox"/>	<input type="checkbox"/>
PF	<input type="checkbox"/>	<input type="checkbox"/>	<input type="checkbox"/>	<input type="checkbox"/>
SV% THD	<input type="checkbox"/>	<input type="checkbox"/>	<input type="checkbox"/>	<input type="checkbox"/>
SI% THD	<input type="checkbox"/>	<input type="checkbox"/>	<input type="checkbox"/>	<input type="checkbox"/>
Frequency	<input type="checkbox"/>	<input type="checkbox"/>	<input type="checkbox"/>	<input type="checkbox"/>
<input type="checkbox"/> Meter Registration				

Storage Device
Insert device; press SCAN

Insert memory storage device and press SCAN when ready

Once the Data Trending software loads, the user can change the total time to display, the time interval, and any high or low limits they wish to put on the data. A total of 6 signals can be trended at once. It should be noted, that an external storage device is required to do data trending.

7.5 Customer Load Setup

Customer Load Test Setup
Selected Site: DELETE

Service Type

Test Setup

Test Mode

Do Demand Test

Test Time Seconds

Test Revs

Meter Model







Mfg SN

Meter No

Setup changes will apply to this test only

Meter Editor
Reset
Next

Functionality:

	Moves to next field
	Moves to previous field
	Enters drop down box and views test mode selections; checks/unchecks check boxes
 	Moves cursor up and down for selecting a test mode in the drop down box
	Resets any changes made back to default database values
	Continues

Description:

This screen allows the user to perform a meter test using the customer's load. This means that the PowerMaster® will calculate the registration (accuracy of the meter under test) over a set timed period (either time or pulses). The end result is expressed as a percent.

The values above are populated using the settings in the Test Editor that is associated with the site installation. These fields cannot be edited in this screen, but must be edited in the Site Editor screen. Any changes apply to this test only.

FAQ's

How do I change the "Kt" in this screen?

The Kt value is pulled from the site installation database. The "Kt" on this screen is considered to be a read-only field (i.e. cannot be edited) to protect the data integrity, so the "Kt" value can only be changed in the Site Editor ([section 6.4](#)) screen. This is done by either selecting a meter in the meter database or overriding the "Kt" value located below the meter entry.

What is the difference between "Test Time" and "Test Revs"?

Test Time is the amount of seconds the user defines for the test. If the time exceeds before a pulse is expected, the PowerMaster® will wait until the last pulse is seen before completing. Test Revs is the amount of pulses or revolutions the meter test will count before completing. If both fields have values present, the meter test will complete when either value comes first (whether it is time or revs).

How many "Revs" does Powermetrix recommend to perform an accurate meter test?

If time permits, 10 revs or more is ideal.

How do I perform a Var-Hr meter test?

First, make sure Test Mode is set to "VARh". Next, verify the meter pulse pickup is aligned to view Var-hr pulses and not Watt-hr. This may incorporate a meter programming change to do this.

7.5.1 Customer Load Setup With Demand Test

Customer Load Test Setup
Selected Site: DELETE

Service Type

Test Setup

Test Mode

Do Demand Test Use Internal Pulser

Demand Period Minutes

Synchronize Test to Clock (End-to-End Testing)

Meter Model







Mfg SN

Meter No

Setup changes will apply to this test only

Meter Editor
Reset
Next

Functionality:

	Moves to next field
	Moves to previous field
	Enters drop down box and views test mode selections; checks/unchecks check boxes
	Moves cursor up and down for selecting a test mode in the drop down box
	Resets any changes made to default database values
	Continues

Description:

This screen allows the user to perform a demand test using the customer's load. This means that the PowerMaster® will accumulate the power (and accuracy of the meter under test) over a set timed period (defined by the demand interval). Min, max, and average values are given over the entire test period.

The values above are populated using the settings in the Test Editor that is associated with the site installation. These fields cannot be edited in this screen, but must be edited in the Site Editor screen.

FAQ's

How do I change the "Kt" in this screen?

The Kt value is pulled from the site installation database. The "Kt" on this screen is considered to be a read-only field (i.e. cannot be edited) to protect the data integrity, so the "Kt" value can only be changed in the Site Editor ([section 6.4](#)) screen. This is done by either selecting a meter in the meter database or overriding the "Kt" value located below the meter entry.

What selection do I use for "Demand Interval"?

This value can usually be found on the meter nameplate.

What is "Synchronize Test to Clock (End-To-End Testing)"?

This feature is normally used for Canadian customers. The first demand interval (5 min) will begin when the PowerMaster® clock is at a minute mark that is divisible by 5. For example, if the demand test starts at 11:03am, the first interval will not start until 11:05am. The next interval will start at 11:10am, and so on. This is used to precisely time the demand intervals for comparison to meter data acquisition systems. With the GPS option, the clock is based on the precise GPS time base. The GPS clock is currently the most accurate time clock in the world.

What is the "Internal Pulser" option?

The Internal Pulser is used when the meter pulses from the meter cannot be used or accessed. Using the internal clock in the analyzer, it simulates a constant pulse count to synch the data acquisition. No meter registration will be displayed when this option is selected.

7.5.2 Customer Load Probe Setup

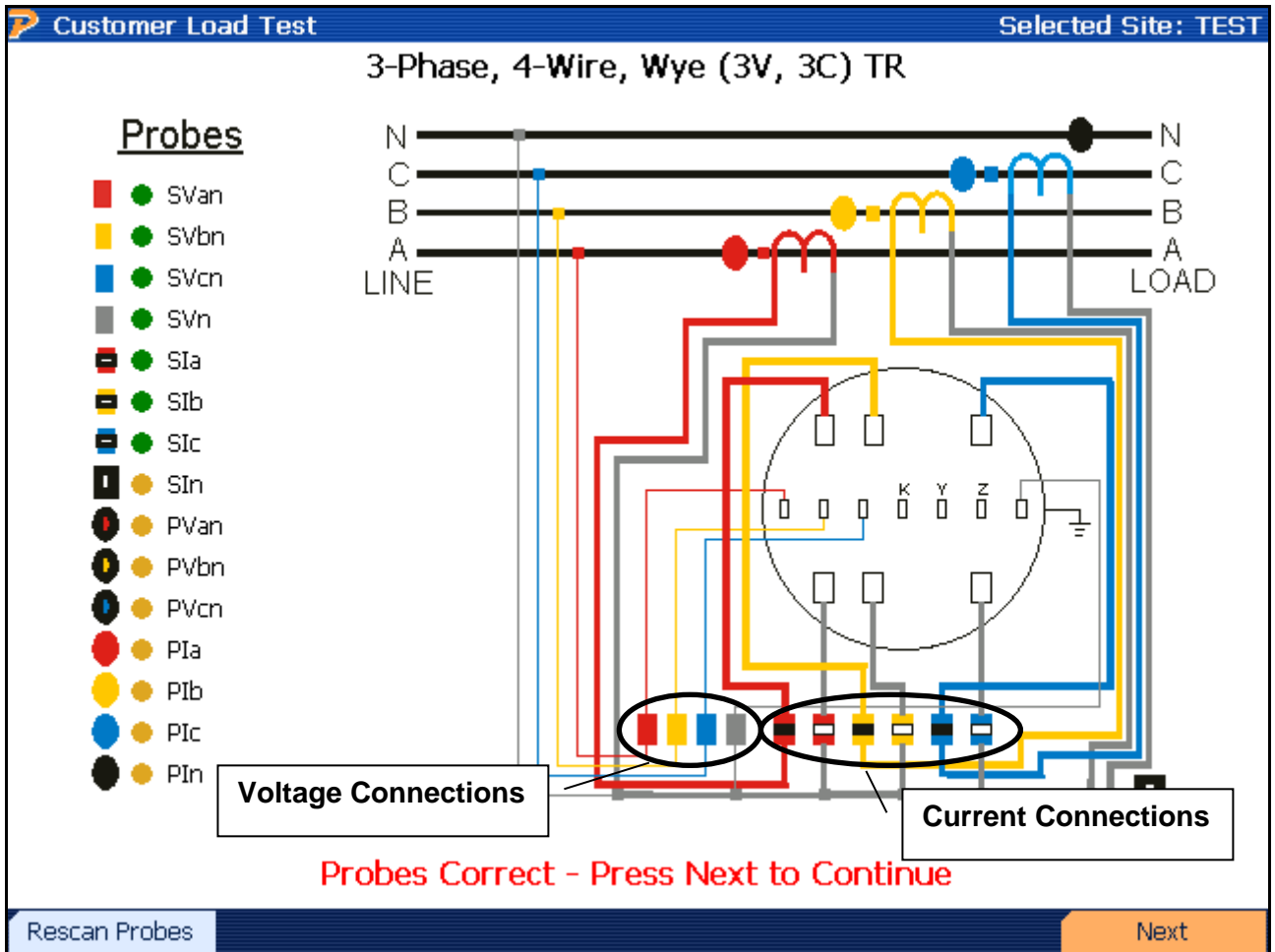

Functionality:

F1	Verifies connected probes if a problem occurs
F6	Continues

Description:

When entering this screen, the PowerMaster® performs both a “Probe Scan” (see [Section 8.6.1](#)) and allows the user to verify probe connections. A key is displayed at the left of the screen and shows what probes are active and required for this test. Color codes are also displayed (A = red, B = yellow, C = blue, N = gray).

7.5.3 Customer Load Final Check

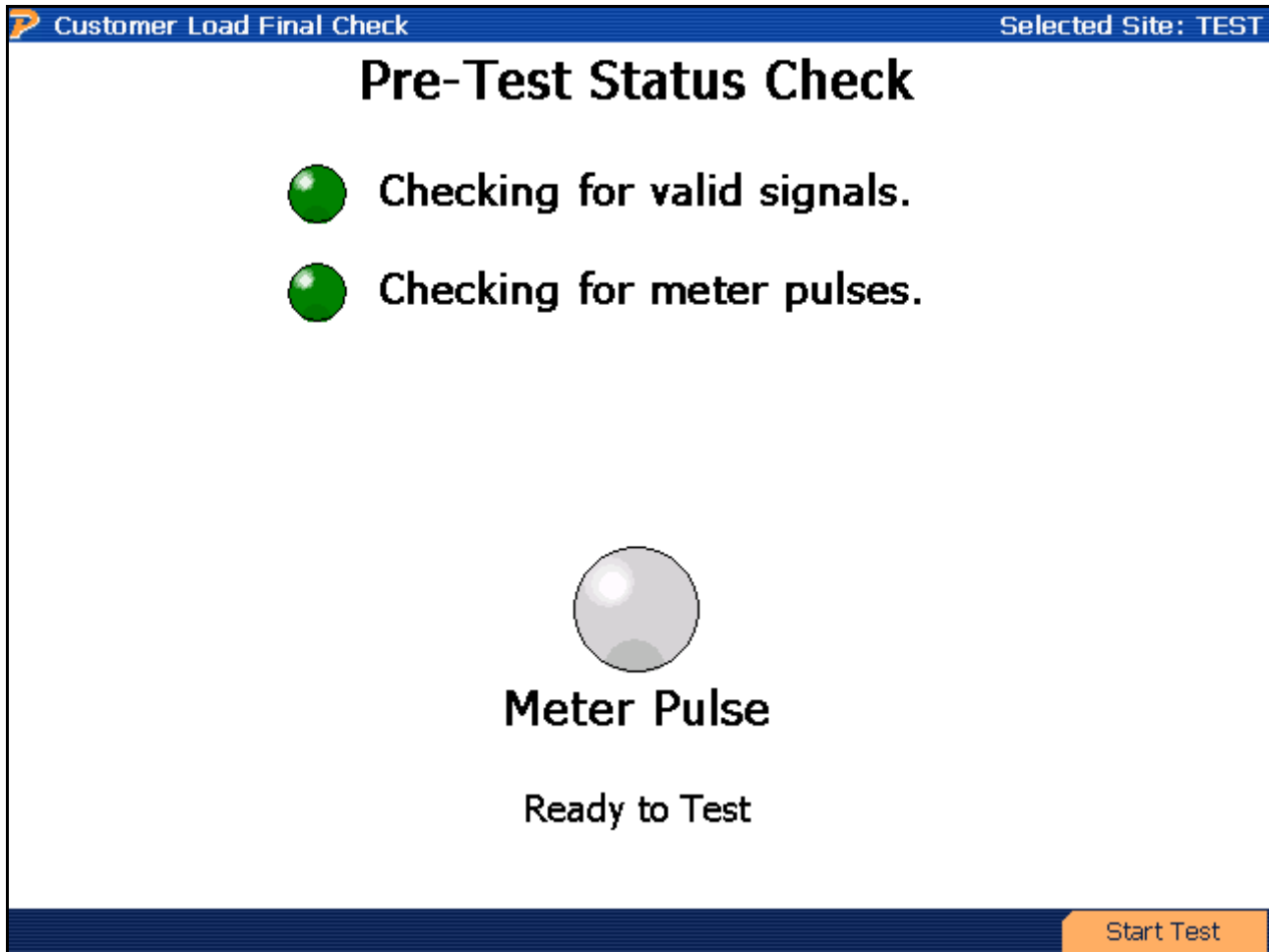

Functionality:

	Continues
---	-----------

Description:

When entering this screen, the PowerMaster® verifies all current and voltage signals are reasonable and allows the user to align the meter pulse pickup at this time. When meter pulses are detected, the signal for “Checking for meter pulses” displays green. Each time a pulse is detected, the “Meter Pulse” signal will light green and display “Ready to Test.” At this time, the user presses F6 to continue to the meter test.

When testing a solid state meter, the meter may be required to be in “test mode.” This normally is done by a toggle switch underneath the meter glass, but in rare cases the user may be required to change the programming of the meter.

7.5.4 Customer Load Test Results

Customer Load Test Results
Selected Site: HIGH SCHOOL

Customer Load Meter Test

Wh Test

% Registration 100.055

Test Info

Time(sec)	20.275
Time Left	0.000
Pulses Exp	2.9984
Pulses Act	3.0000
Meter PF	1.0000

Sys Info

Wh	5.3971
VAh	5.3973
VARh	-0.0435
V	119.473
I	2.6770

Test Complete

Restart
View Trend
Done

Functionality:

F1	Clears all data and restarts meter test
F5	Views the voltage, current, and power (W, VA, VAR) data during the total time interval for the meter test. See section 10.1.4.2 .
F6	Completes meter test and saves data

Description:

When entering this screen, the PowerMaster® begins the meter accuracy test. This screen updates when every pulse is detected. By following the testing parameters set in the setup screen ([Section 10.1](#)), the meter test stops when either time or pulses required is met. Meter accuracy results are displayed at the top center of the screen. Other information during the test is displayed in the bottom right and left sections of the screen. The voltage and current amplitude along with energy is displayed using the System values (see [Section 8.3](#)). Also, the meter accuracy calculation is based off the settings found in the Configuration menu (see [Section 14.2](#)).

FAQ's:**What does Powermetrix consider to be a bad customer load meter test?**

Powermetrix believes a good customer load meter test should be within $\pm 2\%$. Most ct-rated meters are classified at 0.2%, but that accuracy class is based off of lab conditions and under artificial load points (120V @ 2.5 amps). With customer load, the load will vary between the designated test points (FL, PF, LL), and the PowerMaster[®] helps the user determine how well the meter performs under existing conditions (including harmonic content).

[Section 10.1.1](#)), the demand test will stop after time is relinquished. For example, if a 15 minute demand period is selected, the test performs for the next 15 minutes and displays values at each 5 minute interval (15 minutes = 3 intervals). Meter registration is also displayed at each interval.

Synchronize Test to Clock (End-to-End Testing)

When using the “Synchronize Test to Clock (End-to-End Testing)” feature, the first demand interval (5 min) begins when the PowerMaster® clock is at a minute mark that is divisible by 5. For example, if the demand test starts at 11:03am, the first interval will not start until 11:05am. The next interval will start at 11:10am, and so on. This is used to precisely time the demand intervals for comparison to meter data acquisition systems. With the GPS option, the clock will be based on the precise GPS time base. The GPS clock is currently the most accurate time clock in the world.

Synchronize To Meter

If the user would like to compare accumulated results from the PowerMaster® and the meter, enter the Demand Test screen as normal. To synchronize both the meter and the PowerMaster®, do the following: press the RESET on the meter to reset all accumulated demand results and press the F1 (Restart) button then F6 (Start Testing) on the PowerMaster® SIMULTANEOUSLY. This will synchronize the results and accumulate power accordingly. After the test is complete, compare the “Demand Interval” results against the meter. These results are the accumulated power during the demand period.

7.5.4.2 Customer Load Trending Data

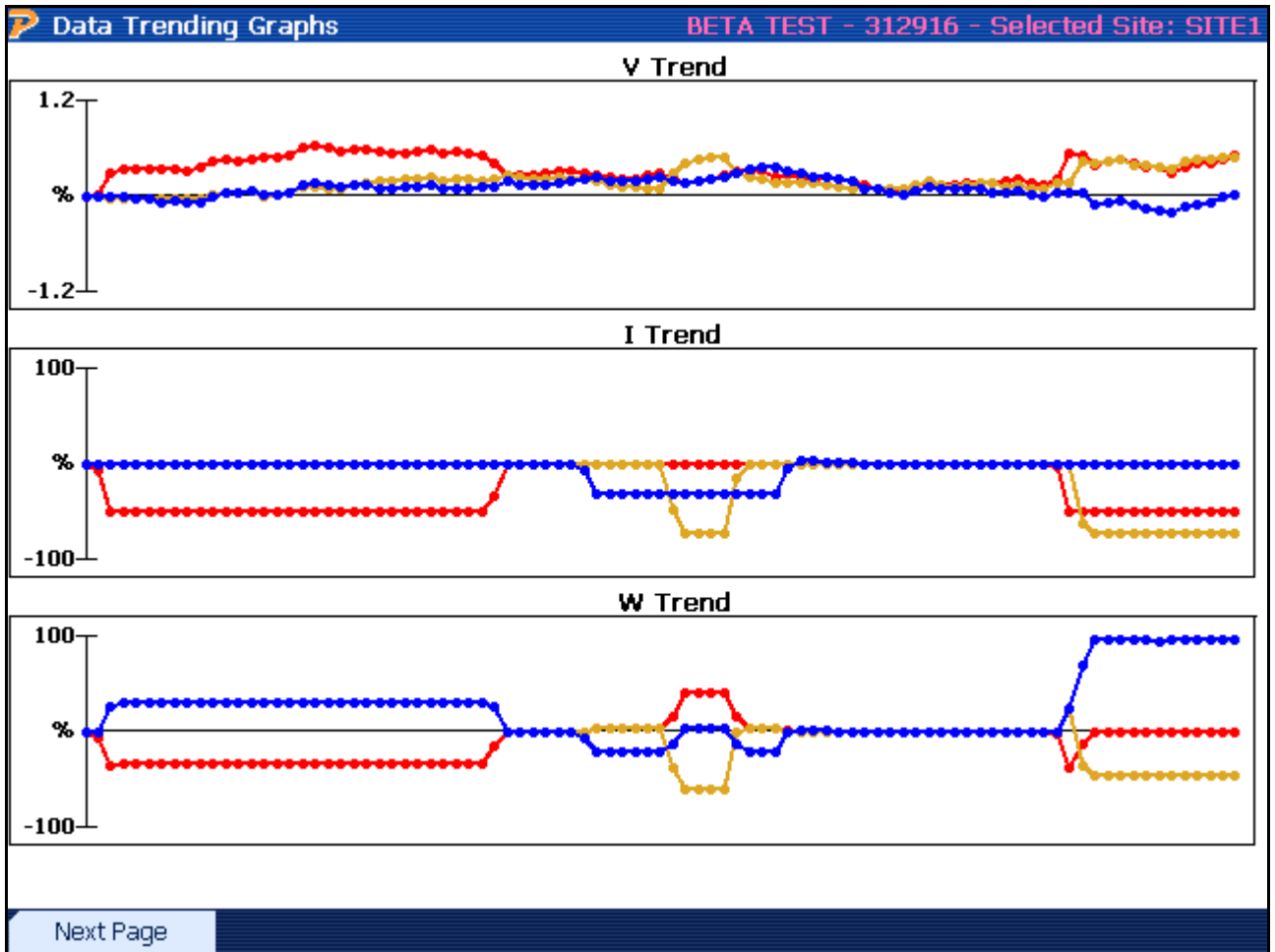

Functionality:

F1	Moves to the next page to display VA, VAR, and PF trend graphs
PREV (END)	Goes back to the test results

Description:

This screen displays the data that is accumulated during the test period. When performing customer load meter tests, the customer's load is normally changing. These graphs give the user a visual perspective of how much the load changed during the test. If the graphs appear to be excessively changing, the user may decide to do a retest when the load is more stable. Also, viewing these graphs gives the user the ability to troubleshoot problems that cannot be immediately seen. For example, if there is a loose connection at the test block for voltages, the graph will display the "peaks" and "valleys" to show the intermittent connections during the meter test (however minuscule in detail).

8 Remote

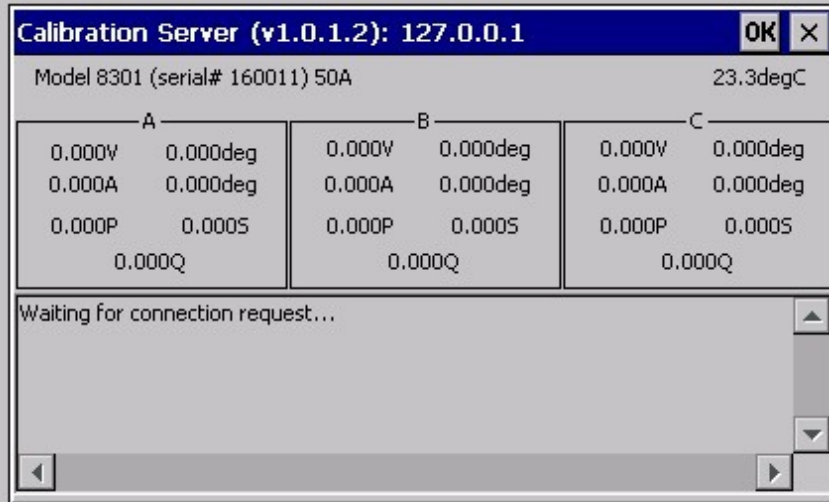

Selecting option 4, "Remote" places the PowerMaster into remote mode. This is only used for calibration. Once selected, if not connected to the calibration standard, the unit will wait for a connection signal. A reboot is required to return the unit to operation.

9 Deselect Site

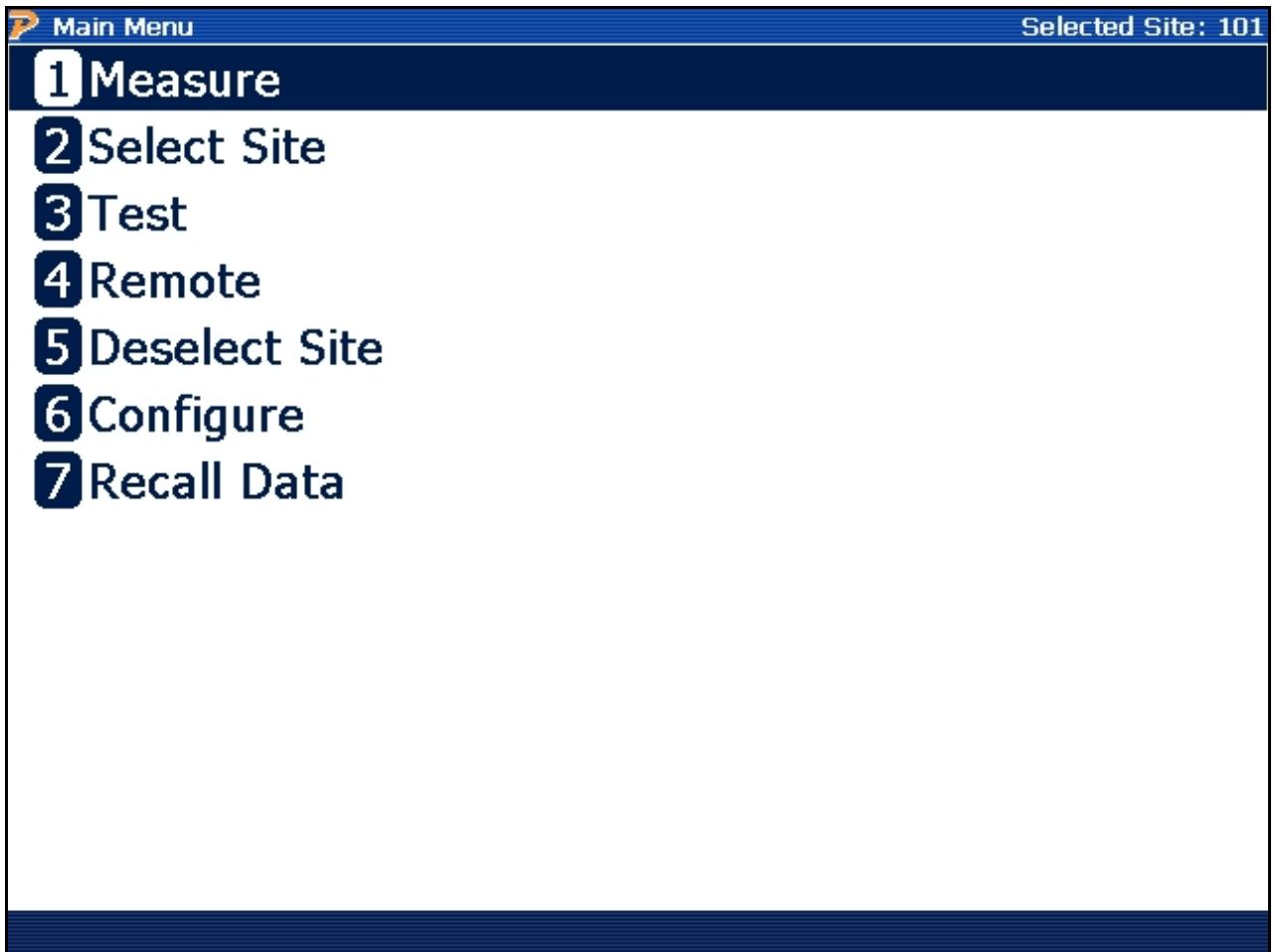

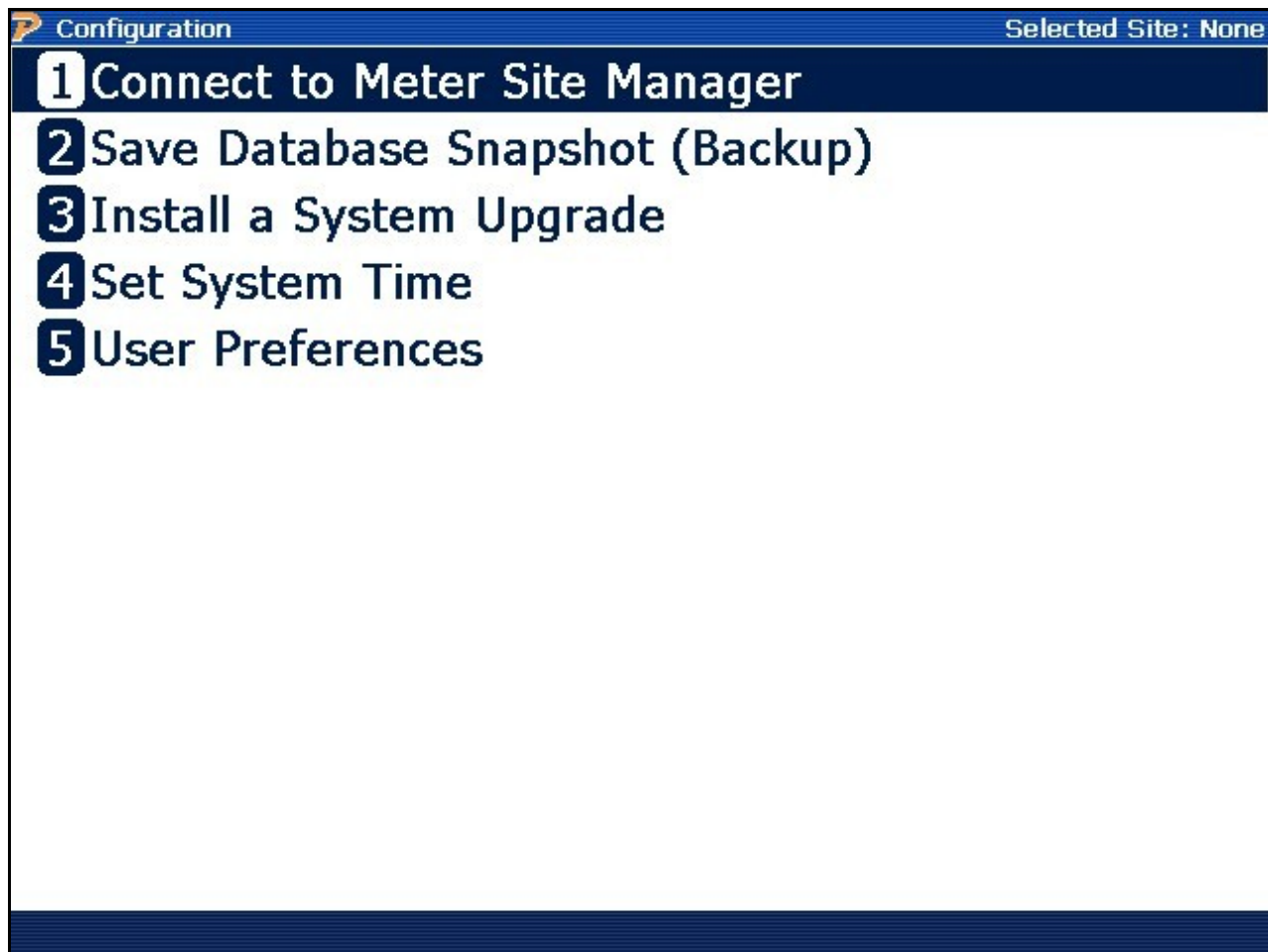

If option 5 shows as "Deselect Site", selecting this option will deselect any current sites.

10 Configure



Functionality:

	Moves cursor up and down to a menu selection
	Accepts and enters menu selection

Description:

The menu allows the user to change the PowerMaster® settings and other various tasks and applications.

10.1 Connect to Meter Site Manager

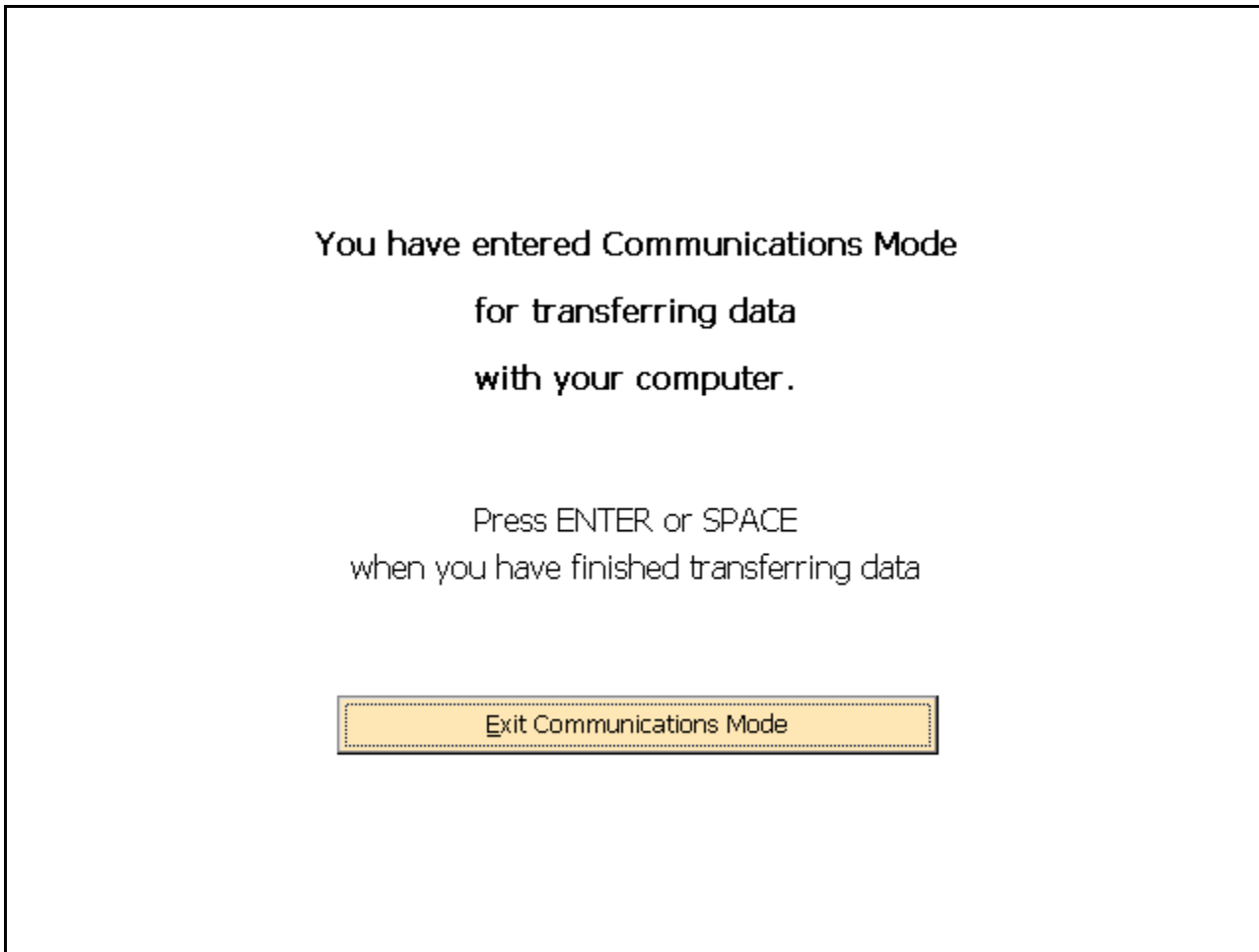

Description:

This screen allows the user to communicate with Meter Site Manager 2. After communications are complete, press Enter or Space to reboot the PowerMaster®.

10.2 Save Database Snapshot (Backup)

Install Upgrade Selected Site: *NONE*



To Save a Database Snapshot:

- * Plug in an SD Memory Card or USB flash drive with plenty of free space, and press the RESCAN button.
- * If the memory storage device has sufficient free space to store a snapshot of the PowerMaster data files, it will appear in the list below. Select it and press CONTINUE.
- * The information will be copied to a subdirectory on the storage device.

WARNING: Do not remove the memory storage device while the backup procedure is in progress, or while the device's write activity light (if any) flashes. Doing so will interrupt the backup and may corrupt data.

Insert memory storage device and press SCAN when ready

Functionality:

	Cancels and returns to Configuration Menu
	Scans flash drive for free space

Description:

When the user may want to back up the PowerMaster® database for security purposes, place a USB flash drive into one of the PowerMaster®'s USB peripheral ports. Next, press F3 to scan the USB flash drive to verify enough space is required to save the database.

As an alternative, the user can run this process instead of downloading the database using Meter Site Manager 2. Refer to the Meter Site Manager 2 Instruction Manual for further details.

The following steps show the user how to update the PowerMaster® in the field:

STEP 1

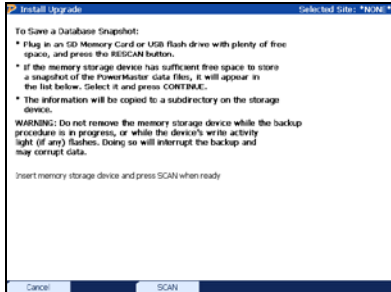

Insert USB Flash drive into a USB peripheral and press F3 to scan

STEP 2

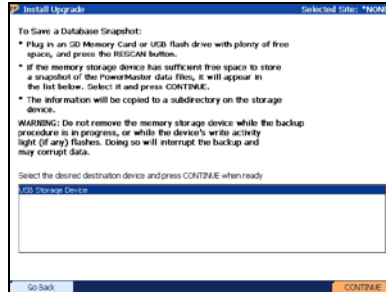

After free space is confirmed, press F6 to begin backup
DO NOT REMOVE USB FLASH DRIVE

STEP 3

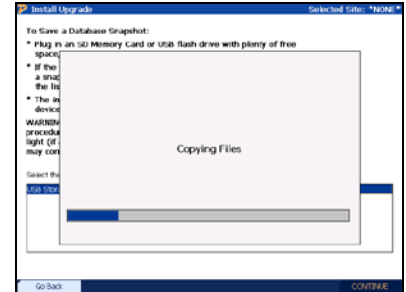

Copy of the database will save to USB flash drive

10.3 Install a System Upgrade

Install Upgrade Selected Site: DELETE

The PowerMaster Analyzer Update Process:



- * Plug a USB flash drive containing a PowerMaster upgrade PMX file into the USB port, then press the SCAN key to find the PMX file.
- * When the list of possible upgrade files appears, use the arrow keys to select the one you wish to install, then press the INSTALL key.
- * When the screen asks you to do so, reset the PowerMaster Analyzer, leaving the USB flash drive plugged in.
- * When the PowerMaster Analyzer reboots, it will find the upgrade file and attempt to install the upgrade.

WARNING: If you remove the USB flash drive before the upgrade process finishes, you may have to plug it back in and reset again in order for the process to complete.

Insert USB flash drive and press SCAN when ready

Cancel SCAN

Functionality:

	Cancels and returns to Configuration Menu
	Scans flash drive for PowerMaster® upgrade file (.PMX)

Description:

When new software updates are available, Powermetrix will contact the user of its availability. The upgrade file package (.PMX extension) must be moved to a USB flash drive. Once the file package is on the USB flash drive, the user will connect it to one of the PowerMaster®'s USB peripheral ports. The following steps show the user how to update the PowerMaster® in the field:

STEP 1

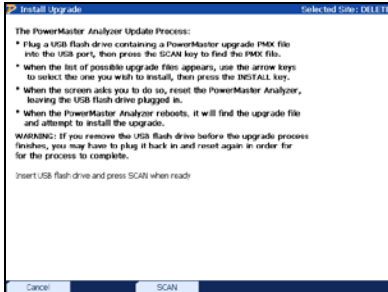

Insert USB Flash drive into a USB peripheral and press F3 to scan

STEP 2

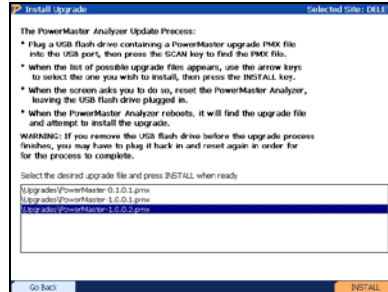

Select the .PMX upgrade file and press F6 to install

STEP 3

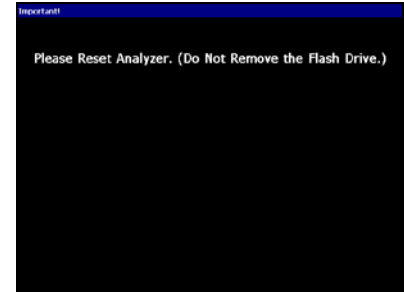

After recognition, reset the PowerMaster® by turning off then turning back on

STEP 4

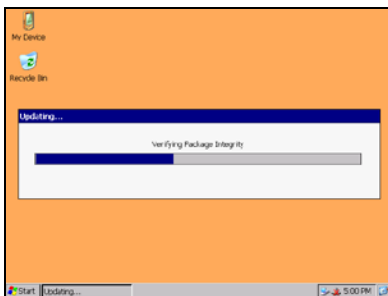

After power up, the PowerMaster® will run the update application automatically (this may take several minutes)

STEP 5

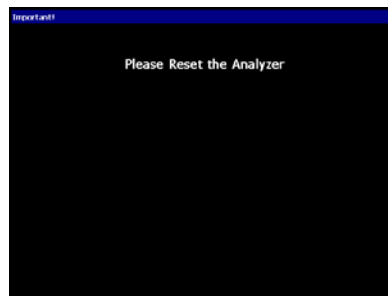

After installation, reset the PowerMaster® by turning off then turning back on

10.4 Set System Time

System Date and Time
Selected Site: *NONE*

The System Time Zone is:

(GMT-05:00) Eastern Time (US and Canada)

IMPORTANT! If the time zone is incorrect, press F3 to correct it now!

Time

Your analyzer is configured to use a 12-hour clock

Hour Minute Second

Automatically Adjust for Daylight Saving Time







Date

Year Month Day

Wednesday

Formats
Time Zone
Save Settings

Functionality:

	Moves to next field
	Moves to previous field
	Enters drop down box and views selections; checks/unchecks check boxes
	Moves cursor up and down for selecting a value in the drop down box
	Changes the time format for domestic and international time zones
	Changes the time zone
	Saves changes and exits

10.5 User Preferences

10.5.1 General Settings

User Preferences
Selected Site: None

Pulse Setup

	Output	1 Phase <input type="text" value="All"/>	Mode <input type="text" value="Wh"/>	Kh <input type="text" value="1000"/>
		2 Phase <input type="text" value="All"/>	Mode <input type="text" value="Wh"/>	Kh <input type="text" value="1000"/>
		3 Phase <input type="text" value="All"/>	Mode <input type="text" value="Wh"/>	Kh <input type="text" value="1000"/>
	Input	1 Phase <input type="text" value="All"/>	Mode <input type="text" value="Wh"/>	Kh <input type="text" value="10"/>
		2 Phase <input type="text" value="All"/>	Mode <input type="text" value="Wh"/>	Kh <input type="text" value="10"/>
		3 Phase <input type="text" value="All"/>	Mode <input type="text" value="Wh"/>	Kh <input type="text" value="10"/>

Measurement Interval

Interval Time Base Seconds



Next Page 1 of 4





Section
Next Page
Save

Each output has available the following choices:

System Wh	Phase A Wh	Phase B Wh	Phase C Wh
System VAh	Phase A VAh	Phase B VAh	Phase C VAh
System VARh	Phase A VARh	Phase B VARh	Phase C VARh

Functionality:

	Moves to next field
	Moves to previous field
	Checks all checkboxes

	Moves cursor up and down for selecting a test mode in the drop down box
	Moves to the next important section of the screen
	Moves to the next set of user preferences
	Saves changes and exits

Description:

This screen allows the user to set general settings in the PowerMaster®.

Default Pulse Output Mode

These options allow the user to customize each of the three pulse outputs. One can select Wh, VARh, or VAh and choose whether the System quantity or a single phase quantity is output. The output pulse rate is set by inputting the number of μ Wh (micro Watt-hours), μ VAh (micro VA-hours), or μ VARh (micro VAR-hours) per pulse. The input range is 10 to 10,000. See the appendix on how to correct set the Kh.

Language

Multiple languages can be selected.

Measurement Interval

When Interval is selected on any Hot screen the display shows the data averaged over a specific period of time. The default value is one second. This preference allows that default to be set to a longer value. Note that changing this value also affects the frequency at which data is sent to a remote device during streaming operations.

10.5.2 Measurement Setup

User Preferences Selected Site: None

Measurement Setup

Selections here determine which definition for the quantity will be used for Meter Accuracy Tests

Voltage (V)

FDrms - Computed in the frequency domain, all harmonics included

Current (I)

FDrms - Computed in the frequency domain, all harmonics included

Active Power (W)

P1 - Computed using fundamentals only

Reactive Power VARs (Q)

Q1 - Computed using fundamentals only, $V(\text{fund}) * I(\text{fund}) \cos(\phi)$

Apparent Power VA (S)

S1 - Computed using fundamentals only, $V(\text{fund}) * I(\text{fund})$

Power Factor (PF)

PF1 - Computed using fundamentals only, $P1/S1$











System Calculations

Vector

Next Page 2 of 4

Section	Next Page	Time Domain	Fundamental	FFT Based	Save
---------	-----------	-------------	-------------	-----------	------

Functionality:

	Moves to next field
	Moves to previous field
	Enters drop down box and views test mode selections
	Moves cursor up and down for selecting a test mode in the drop down box
	Moves to the next important section of the screen
	Moves to the next set of user preferences
	Changes all calculations using the time domain
	Changes all calculations using the fundamental only (no harmonics)
	Changes all calculation using frequency (default)
	Saves changes and exits

Description:

The following describes how the PowerMaster® specifically calculates power according to the user’s selections above:

TIME DOMAIN¹

In Time Domain, data is processed on a point by point basis and the results integrated over precisely one cycle of the incoming signal. The quantities calculated are:

Calculations

$V_{rms} = \sqrt{\frac{1}{N} \sum_n V_n^2}$	V(TDRMS) - The processing properly accounts for the exact number of samples in a cycle including fractional data points
$I_{rms} = \sqrt{\frac{1}{N} \sum_n I_n^2}$	I(TDRMS)
$Pa = \frac{1}{N} \sum_n V_i I_i$	Active Power (Pa) – Calculation includes any DC component as well as all frequencies in the signal up to the cutoff frequency of 32 kHz.

$Sa = VA = V_{rms}I_{rms} = \sqrt{\frac{1}{N} \sum_{i=0}^{i=N-1} V_i^2} \cdot \sqrt{\frac{1}{N} \sum_{i=0}^{i=N-1} I_i^2}$	Apparent Power (Sa) - Calculation includes any DC component as well as all frequencies in the signal up to the cutoff frequency of 32 kHz.
$Qa = \sqrt{S^2 - P^2}$	Reactive Power (Qa) – There is not a good formulation in the time domain for directly computing Q. We have adopted the approach of computing it from the “Power Triangle” assumption.
$PFa = \frac{Pa}{Sa}$	Power Factor (PFa)

FREQUENCY DOMAIN²

In Frequency Domain (FFT), Every 2048 data points a complete Fourier analysis is performed. The user has control over the maximum number of harmonics to be included in the analysis as well as the ability to set a threshold which can exclude harmonics whose amplitude is below the user set threshold (see [section 14.1](#)). While time domain calculations of power quantities yield energy directly because they are integrals, Fourier calculations deliver average rates over the time interval of the analysis.

According to Fourier's Theorem any **periodic** signal can be represented in the following manner:

$$V(t) = \frac{a_0}{2} + \sum_{n=1}^{\infty} (a_n \cos(n\omega_0 t) + b_n \sin(n\omega_0 t))$$

The PowerMaster[®] calculates a_n , b_n and ω_0 for $n = 0$ to 100. Given these parameters we can calculate any of the quantities of interest as follows:

Calculations:

$V_{rms} = \frac{1}{(2)^{1/2}} \left[\sum_n (a_{vn}^2 + b_{vn}^2) \right]^{1/2}$	Vt(FDRMS) – RMS voltage computed using all harmonics which pass the user definable filter. ¹
$I_{rms} = \frac{1}{(2)^{1/2}} \left[\sum_n (a_{in}^2 + b_{in}^2) \right]^{1/2}$	It(FDRMS) – RMS current computed using all harmonics which pass the user definable filter. ¹
$Pt = \sum_n \vec{V}_n \cdot \vec{I}_n = \sum_n (a_{vn} a_{in} + b_{vn} b_{in})$ $= \sum_n V_n I_n \cos(\theta_n)$	Pt(FD) – Active power computed by summing the vector dot products of each of the harmonics ¹
$Qt = \sum_n \vec{V}_n \times \vec{I}_n = \sum_n (a_{vn} b_{in} - a_{in} b_{vn})$ $= \sum_n V_n I_n \sin(\theta_n)$	Qt(FD) – Reactive power computed by summing the vector dot products of each of the harmonics ¹
$St = \frac{1}{2} \left[\sum_n (a_{vn}^2 + b_{vn}^2)(a_{in}^2 + b_{in}^2) \right]^{1/2}$	St(FD) – Apparent power computed by summing the Vrms times Irms for each harmonic.
$PFt = \frac{Pt}{St}$	Power Factor (PFt)

Note:

¹ The a_0 component is not included in numbers reported by the PowerMaster[®].

² Normalization constants have been omitted for simplicity

FUNDAMENTAL ONLY

For Fundamental Only, the PowerMaster® uses a subset calculation from the Frequency Domain. In this case, harmonics are *not* included in the analysis.

Calculations:

$V1 = \frac{1}{(2)^{1/2}} [a_{v1}^2 + b_{v1}^2]^{1/2}$	V1(FDRMS) – RMS voltage for the fundamental frequency only.
$I1 = \frac{1}{(2)^{1/2}} [a_{i1}^2 + b_{i1}^2]^{1/2}$	I1(FDRMS) – RMS current for the fundamental frequency only.
$P1 = \vec{V}_1 \bullet \vec{I}_1 = a_{v1}a_{i1} + b_{v1}b_{i1} = V_1I_1 \cos(\theta_1)$	P1(FD) - Active power for the fundamental only
$Q1 = \vec{V}_1 \times \vec{I}_1 = a_{v1}b_{i1} - a_{i1}b_{v1} = V_1I_1 \sin(\theta_1)$	P1(FD) - Reactive power for the fundamental only
$S1 = \frac{1}{2} (a_{v1}^2 + b_{v1}^2)^{1/2} (a_{i1}^2 + b_{i1}^2)^{1/2}$	S1t(FD) – Apparent power computed as Irms times Vrms for the fundamental only.
$PF1 = \frac{P1}{S1}$	Power Factor (PF1)

10.5.3 Additional Settings

User Preferences
Selected Site: None

Save Additional Data After Meter Tests

Meter Trend Data

Waveforms

Significant Harmonics

Demand Test Options

Demand Test: Five Minute Intervals

Demand Test: View Demand Sum

Harmonic Limits

Max to Save

Min Threshold % (A Low Threshold Saves MORE Data)

General Settings

Language

Enable audio feedback

System Frequency Vector Diagram Placement

General Volume Meter Beep Volume









Display Preferences

Display Phase Difference Metering Type

Phase A Color Phase B Color Phase C Color

Next Page 3 of 4

Section
Next Page
Save

	Moves to next field
	Moves to previous field
	Enters drop down box and views test mode selections; checks/unchecks check boxes
 	Moves cursor up and down for selecting a test mode in the drop down box
	Moves to the next important section of the screen
	Moves to the next set of user preferences
	Saves changes and exits

Description:

This screen allows the user to set the error limits for testing and how much (or little) data is saved.

Error Limits

The three error limits are based on the accuracy class of the component. For example, if the meter has an accuracy class of 0.2% and an error limit set to “2.0x Specification Accuracy,” the PowerMaster® will only display an error if the registration is outside of 99.60% and 100.40%.

Accuracy class = 0.2%

Error Limit = 2.0x Specification Accuracy

$0.2 * 2 = \pm 0.4\%$

Optionally, the user selects “User Defined Accuracy” to set a custom error limit

Save Additional Data After Meter Tests

The user has the option to save additional information:

Meter Trend Data: This option saves the trending graphs to the database.

Waveforms: This option allows the user to auto save during a Meter Test and manually save the waveform diagrams.

Significant Harmonics: This option allows the user to auto save during a Meter Test and manually save the harmonic information.

Demand Test Options

This allows the user to choose the timed intervals for a demand test. Choices available are 5 minute or 3 minute intervals. The user also has the ability to change the display from energy (Whr) or demand (W) accumulation.

Harmonic Limits

This option is displayed when “Significant Harmonics” is selected. This narrows down the number of harmonics the user feels significant and wishes to save to the database.

Max to view: This allows the user to select how many harmonics are displayed on the screen

Min Threshold: This option sets the minimum harmonic distortion percentage to be saved. For example, if the user sets the minimum to 1%, all harmonics that are 0.9% and below will not be saved. This prevents the user from saving too much unnecessary data to the database.

10.5.4 User Defined Fields for the Test Session

User Preferences
Selected Site: None

Custom Fields for Test Session

CT A <input style="width: 40px;" type="text" value="5"/> :5	CT B <input style="width: 40px;" type="text" value="5"/> :5	CT C <input style="width: 40px;" type="text" value="5"/> :5
PT A <input style="width: 40px;" type="text" value="1"/> :1	PT B <input style="width: 40px;" type="text" value="1"/> :1	PT C <input style="width: 40px;" type="text" value="1"/> :1





Custom Fields for Test Session

UTS11 <input style="width: 100px;" type="text" value="UTS11"/>	UTS12 <input style="width: 100px;" type="text" value="UTS12"/>	UTS13 <input style="width: 100px;" type="text" value="UTS13"/>
UTS21 <input style="width: 100px;" type="text" value="UTS21"/>	UTS22 <input style="width: 100px;" type="text" value="UTS22"/>	UTS23 <input style="width: 100px;" type="text" value="UTS23"/>
UTS31 <input style="width: 100px;" type="text" value="UTS31"/>	UTS32 <input style="width: 100px;" type="text" value="UTS32"/>	UTS33 <input style="width: 100px;" type="text" value="UTS33"/>
UTS41 <input style="width: 100px;" type="text" value="UTS41"/>	UTS42 <input style="width: 100px;" type="text" value="UTS42"/>	UTS43 <input style="width: 100px;" type="text" value="UTS43"/>

Next Page 4 of 4

Section
Next Page
Save

Functionality:

	Moves to next field
	Moves to previous field
	Moves to the next important section of the screen
	Moves to the next set of user preferences
	Saves changes and exits

Description:

This screen allow the user to change the labels for custom fields in the PowerMaster®. The Custom Fields for Test Session are directly input into the database. They can be exported from the database, but cannot be directly viewed from Meter Site Manager 2.

11 Recall Data





Select Test
Selected Site: 101

Select the Data to Review

- [-] 101 - HIGH SCHOOL
 - [+] 1/1/2003 from 8:05 PM
 - [-] 1/2/2003 from 12:28 PM
 - [-] CT Test - 1/2/2003 1:17:09 PM
 - [-] Customer Load Test - 1/2/2003 12:28:18 PM
 - [+] 1/2/2003 from 4:15 PM
 - [+] 1/2/2003 from 4:23 PM
 - [+] 1/3/2003 from 1:08 PM
 - [+] 1/3/2003 from 3:15 PM
 - [+] 10/11/2008 from 1:31 PM
 - [+] 10/15/2008 from 10:48 AM
- [-] 102 - GROCERY
- [-] 103 - Walmart#137

Expand

Functionality:

	Moves to next section
	Moves to previous section
	Expands boxes
	Expands boxes or Selects data to view

Description:

This screen allows the user to view saved data for each site installation in the database. After the user “expands” the data, the user presses F6 to view the stored information.

12 Specifications

Overview

Current Direct Channels	3x (0.1 to 50 amps)
Voltage Direct Channels	3x (30 to 600 VAC)
Probe Channels	6x (0.001 to 3.2 VAC)
System Power	85 to 264 VAC , 47 to 63Hz, 100W max
Frequency	45-65 Hz
Harmonic Analysis	Maximum of 50 th harmonic
Phase Angle	0° to 360°
Power Factor	-1.00 to 1.00
Standard Operating Temperature	23°C ±2°C ambient

AC Voltage Channels

Channels	4
Range	30 to 600Vrms
Resolution	± 0.0001V
Model 8302 Accuracy ⁽¹⁾	*(R1) 10 to 55 V , ±0.02%, Phase Error < 0.001° *(R2) 55 to 600 V , ±0.01%, Phase Error < 0.001°
Model 8304 Accuracy ⁽¹⁾	*(R1) 10 to 55 V , ±0.04%, Phase Error < 0.002° *(R2) 55 to 600 V , ±0.02%, Phase Error < 0.002°

AC Current Channels

Channels	3
Range	0.02 to 50.0 amps
Resolution	± 1 µA
Model 8302 Accuracy ⁽¹⁾	*(R1) 0.08A to 0.4A , ±0.05%, Phase Error < 0.01° *(R2) 0.4A to 50A, ±0.02%, Phase Error < 0.003°
Model 8304 Accuracy ⁽¹⁾	*(R1) 0.08A to 0.4A , ±0.1%, Phase Error < 0.02° *(R2) 0.4A to 50A, ±0.04%, Phase Error < 0.006°

Probe Channels

Channels	6
Input Range	0.001V to 3.2 V(RMS), ±5.0 V peak
Resolution	up to 7 significant digits

Accuracy ⁽¹⁾	*(R1) 0.001 to 0.032 V , 0.04% ±10μV *(R2) 0.032V to 3.2V, 0.02% Phase Error < 0.003°
-------------------------	---

Frequency Accuracy

Reference	19.6608 MHz TCXO
Base Accuracy	±1.5 ppm
Temperature Effect	Maximum Error ±2.5 ppm over -30°C to +85°C range
Stability	Better than ±1.0 ppm/yr

Power Measurement Modes

Parameters	Wh, VARh, VAh, PF Note: There is no US standard definition for VARs. We certify that our measurements of VARs match the definitions in our documentation to the specified accuracy.
Model 8302 Whr Accuracy	*(R2): ±0.02% *(R1): ±0.04%
Model 8304 Whr Accuracy	*(R1) ± 0.08% *(R2) ± 0.04%
Definitions	System can calculate each quantity using a variety of user selectable definitions. Either full spectrum or fundamental only calculations are available.

Environmental

Temperature (Normal)	23°C ±2°C
Humidity	0% to 95% non-condensing

Communication

USB Device Ports (links to computer)	1
USB Master Ports (links to peripherals)	2
RS232 Port	1
Ethernet Port	1

Physical

Display Resolution	Full color VGA (640x480)
Display Size	8.4 inch
Dimensions (H x W x D)	10.5" x 19" x 9.5"
Weight	12.8 lbs (5.8 kg)
Case	ELMA Type 14 Rack mount enclosure 3U x 9.5"

Power











Mains Supply	85 to 264 VAC, 47 to 63Hz, 100W max
--------------	-------------------------------------

(1) Accuracies are stated as 95% confidence level maximum error as a percent of reading.

*All amplitude errors are expressed as percent of measurement. All phase errors are expressed in degrees at 60 Hz. R1 = Range 1, R2 = Range 2

All accuracy specifications are over the "Standard Operating Temperature" (23°C). Performance exceeding $\pm 2^\circ$ from 23°C is reduced by 10ppm/°C outside the Standard Operating Temperature. Measurements made using the AC Current Direct and AC Voltage channels.

13 Accessories

	Part Number	Product	Notes
	10-340-0027	3-Phase Test Switch Current Direct Probes	0.1- 20A, 600V. Used for insertion into test switch.
	10-340-0037	3-Phase Test Switch Current Direct Probes (for Models 7305, 7335)	0.1- 20A, 600V. Used for insertion into test switch.
	10-340-0005	3-Phase Voltage Cable (for Models 7300, 7302, 7305)	10 - 600V. Terminated with banana jacks to allow user customization
	10-340-0006	3-Phase Voltage Cable (for Models 7332, 7335)	10 - 600V. Terminated with banana jacks to allow user customization
	10-340-0014	3-Phase Probe Adapter Cable	Used for all current and voltage probes
	10-100-1036	36" Flexible Current Probe	5 – 1000A. Normally used as a CT probe
	10-340-0026	15' Extension Cable	Extension for any probe.
	EP10-100-3327	IR Pulse Detector	For interfacing to the pulse output of solid state meters
	75-800-4005	USB Communication Cable	Type B USB cable for communication to a computer
		Meter Site Manager	Software to be used on a PC or laptop; Used for communicating with the PowerMaster®
		User Manual	Printed manual for reference

13.1 Current Probes

10-100-3353 Set of (3) MN353 Clamp-On Probes

These probes are normally used if no test switch is present or for testing a class 200 self-contained meters.

	Range	0.1 – 150A
	Max Voltage	600V
	Opening	0.83" (21mm)
	Accuracy	TBD

10-100-3375 Set of (3) MN375 Clamp-On Probes

These probes are normally used if no test switch is present.

	Range	0.1 – 10A
	Max Voltage	600V
	Opening:	0.83" (21mm)
	Accuracy:	TBD

Z-SR752-PKG Set of (3) SR752 Clamp-On Probes

These set of clamp-on probes are normally used for class 200, 400, and 600 self-contained meter testing or CT ratio testing.

	Range	0.001 – 1200A
	Max Voltage	600V
	Opening:	2.25" (57mm)
	Accuracy:	TBD

10-100-1036 36" Flexible Current Probe 1000A

These probes are normally used for used for class 200, 400, and 600 self-contained meter testing or CT ratio testing. Other current ranges available upon request.

	Range	5 – 1000A
	Max Voltage	600V
	Opening:	N/A
	Accuracy:	TBD

10-100-1048 48" Flexible Current Probe 1000A

These probes are normally used for used for class 200, 400, and 600 self-contained meter testing or CT ratio testing. Other current ranges available upon request.

	Range	5 – 1000A
	Max Voltage	600V
	Opening:	N/A
	Accuracy:	TBD

10-140-8016 Amp LiteWire Probe

These probes are normally used for used for CT ratio testing. They can be used for high voltage (> 600V) or low voltage (< 600V) installations.

	Range	1 – 2000A
	Max Voltage	150,000V
	Opening:	N/A
	Accuracy:	TBD

10-140-8014 Volt LiteWire Probe

These probes are used for used for PT ratio testing. They can measure phase to ground, or phase to phase measurements.

	Range	1 – 40,000V
	Max Voltage	40,000V
	Opening:	N/A
	Accuracy:	±2% of reading

CURRENT & VOLTAGE DIRECT LEADS

10-340-0028 3-Phase Current Lead Set (terminated with alligator clips)

This lead set is normally used for class 20 CT connected meters and CT testing.

	Range	0.1 – 20A
	Voltage	277 VAC to ground

10-340-0007 3-Phase Current Lead Set (ring terminals)

This lead set is normally used for class 30 or class 50 self-contained. Ring terminals allow the user flexibility in testing in both the lab and field applications.

	Range	0.1 – 50A
	Voltage	277 VAC to ground

10-340-0039 3-Phase Current Lead Set (terminated with 6mm plugs)

Secondary current measurement and burden testing through insertion of 6mm female receptacle plugs typically found on energy standards and 3-phase power sources. Can also be used with MTA15 Universal Meter Test Adapter (10-130-0015).

	Range	0.1 – 50A
	Voltage	277 VAC to ground

CABLES & ADAPTERS

10-340-0026 15 Foot Probe Extension Cable

This cable is terminated with 8-pin connectors. Multiple cables can be connected serially for longer lengths - maximum length 45 feet. Any type of probe can be used with this extension cable.

10-340-0025 BNC to PowerMaster® Probe Adapter Cable

For connection to High Voltage Amp or Volt Litewire probe

75-700-2001 40' Fiber Optic Replacement Cable

For High Voltage Amp and Volt Litewire Probes

SPARE PARTS

22-100-1550 Hard Carrying Case for Accessories

Rugged, watertight case. Can also be used as spare PowerMaster® carry case

EP10-320-3309 RS232 Cable Assy – comm.

75-800-4005 USB Cable

75-300-9001 Replacement clip for Flexible Current Probes

50-950-0001 White Alligator Clip

50-950-0002 Black Alligator Clip

50-950-0003 Red Alligator Clip

50-950-0004 Yellow Alligator Clip

50-950-0005 Blue Alligator Clip

50-950-0006 Green Alligator Clip

METER TESTING PICKUPS

EP10-100-3309 Suction Cup Infrared Pulse Pickup

Infrared pulse detector with suction cup mount for attachment to electronic meter face.

10-120-0005 Isolated KYZ Contact Pickup

Rated for use on dry contacts or powered contacts up to 480 Vac. Connected to terminal blocks via rugged mini clips.

EP10-100-3326 Photo Disk Detector with Flexible Arm Mount

Sensor detects meter revolutions using a reflective mode optical pickup. For mechanical meters.

EP10-100-3311 Manual Pushbutton Switch

This pushbutton provides a manual pulse input to verify meter accuracy for any meter (6' lead).

METER BASE ADAPTERS

75-310-0013 Form 9 Meter Base Test Adapter (13 Terminal)

Also used with Form 8 and Form 6 installations

75-310-0008 Form 5 Meter Base Test Adapter (8 Terminal)

75-310-0006 Form 4 Meter Base Test Adapter (6 Terminal)

Also used with Form 3 installations.

10-130-0015 MTA15 Test Adapter

Passive meter base test adapter in a rugged Pelican case. Allows the testing of any self-contained or transformer rated socket meters. Connections can be terminated using standard PowerMaster® current and voltage leads, or using 6mm plugs. Load completely driven using the PowerMaster® current and/or voltage output.

CALIBRATION CHECK ACCESSORIES

10-340-0031 External Digital Cable

Multi-function cable adapter for the AUX DIGITAL input on the PowerMaster®. Used for a standard pulse output/input.

10-340-0035 External Digital Cable (STD OUT only)

Condensed version of 10-340-0031 where the measurement of the standard's energy pulse output are only required.

10-340-0046 External Digital Cable (STD OUT, STD IN only)

Condensed version of 10-340-0031 where the measurement of the standard's energy pulse output or the PowerMaster's® pulse input are only required.

10-340-0033 Series 20A Current Test Cable (7300, 7302, 7332 only)

Secondary current measurement when performing series-parallel testing for standards comparison.

10-340-0036 Series 50A Current Test Cable (7305, 7335 only)

Secondary current measurement when performing series-parallel testing for standards comparison

10-340-0045 AUX Power, US AC plug to Safety Banana Plug Adapter

Allows insertion of auxiliary power, neutral, and ground leads into a safe AC adapter. Recommended for all lab applications.

14 Precision Pulse Output Description

Introduction

The PowerMaster® incorporates a high accuracy pulse output which can be driven by any of the following quantities:

Active Power (P):	Pa:	active power computed in the time domain (once per cycle). Includes DC and all frequency components up to 16 kHz.
	P1:	active power computed in the frequency domain (once every four cycles). Includes only the fundamental frequency component.
	Pt:	active power computed in the frequency domain (once every four cycles). Can include up to the 100 th harmonic. The maximum number of harmonics to include are user selectable. A threshold (as a percent of the fundamental) can also be set to exclude harmonics with very low amplitudes.
Reactive Power (P):	Qa:	reactive power computed in the time domain (once per cycle). Includes DC and all frequency components up to 16 kHz.
	Q1:	reactive power computed in the frequency domain (once every four cycles). Includes only the fundamental frequency component.
	Qt:	reactive power computed in the frequency domain (once every four cycles). Can include up to the 100 th harmonic. The maximum number of harmonics to include are user selectable. A threshold (as a percent of the fundamental) can also be set to exclude harmonics with very low amplitudes.
Apparent Power (P):	Sa:	reactive power computed in the time domain (once per cycle). Includes DC and all frequency components up to 16 kHz.
	S1:	reactive power computed in the frequency domain (once every four cycles). Includes only the fundamental frequency component.
	St:	reactive power computed in the frequency domain (once every four cycles). Can include up to the 100 th harmonic. The maximum number of harmonics to include are user selectable. A threshold (as a percent of the fundamental) can also be set to exclude harmonics with very low amplitudes.

Appendix 1

For accuracy purposes, below is the references that should be used for setting the K/h value as a pulse output.

Power levels from 36 kW to 90 kW can be measured with the 8300 using a **Kt value no lower than** $10 \cdot \frac{\mu\text{W} \cdot \text{hr}}{\text{pulse}}$

Power levels from 36 kW to 90 kW can be measured with the 8300 using a **Kt value no lower than** $25 \cdot \frac{\mu\text{W} \cdot \text{hr}}{\text{pulse}}$

Maximum accurate pulse frequency out of the "Standard Out" output, fmax_out, is measured to be a pulse rate corresponding to the 3 phase power of 480V at 25A. The test power is applied to both the Radian RD-33 and the 8300 Powermaster. Registration indicated by the Radian is used to check the 8300 "Standard Out". Registration indicated by the 8300 is used to check the 8300 "Standard In". Accuracy is adequate when registration errors are better than 50 ppm after a short warm up (20 minutes). Registration errors much, much greater than 50 ppm are seen at power levels producing "Standard Out" pulse rates beyond the maximum frequency output.